

SUBDIVISION COMMITTEE REPORT

DATE: July 15, 2020

TO: OC Subdivision Committee

FROM: OC Development Services / Land Development Division

SUBJECT: "B" Vesting Tentative Tract Map 19108 within Planning Area 2, Subarea 2.3, Ranch Plan Planned Community

PROPOSAL: Applicant The New Home Company requests approval of "B" Vesting Tentative Tract Map 19108 (VTTM 19108) to subdivide a 1.21-acre site within Subarea 2.3 of the Ranch Plan Planned Community into 9 legal lots: 7 numbered lots for conventional single-family detached dwellings, 1 numbered lot for a neighborhood pocket park, and 1 lettered lot for a landscaped area.

ZONING: Ranch Plan Planned Community (PC) – Conventional Single-Family Detached Dwellings (PC Section III.A.2)

GENERAL PLAN: 1B "Suburban Residential"

LOCATION: The project site is located on Lots 24-33 of Tract 17605 within Subarea 2.3 of the Ranch Plan Planned Community, in the Fifth (5th) Supervisorial District.

**LANDOWNER/
SUBDIVIDER:** RMV PA2 Development, LLC, ("RMV")
It should be noted that the current landownership is RMV, but upon final recordation, VTTM 19108 will be owned by the New Home Company

APPLICANT: The New Home Company
Matthew Blain, Project Manager, The New Home Company

STAFF CONTACT: Robert Zegarra, Contract Planner, Land Development Division
Phone: (714) 667-8893
Email: Robert.Zegarra@ocpw.ocgov.com

RECOMMENDED ACTION(S):

OC Land Development recommends that the Subdivision Committee:

- 1) Receive and review staff report;
- 2) Find that Final EIR 589, previously certified on November 8, 2004; Addendum 1.0 (PA060023) approved July 2006, Addendum 1.1 (PA110003-06) approved February 24, 2011, the Planning Area 2 Addendum (PA130001-06) approved March 27, 2013, and Addendum 3.1 (PA140072-81) approved February 25, 2015, reflect the independent judgment of the County and are adequate to satisfy the requirements of CEQA for approval of Vesting Tentative Tract Map (VTTM) 19108, which is a necessarily included element contemplated as part of the whole of the action considered in Final EIR 589, Addendum 1.0, Addendum 1.1, and the Planning Area 2 Addendum.
 - a. The circumstances of the project are substantially the same as described in Final EIR 589, Addendum 1.0, Addendum 1.1, the Planning Area 2 Addendum, and Addendum 3.1 which adequately addressed the effects of the project proposed in VTTM19108. No substantial changes have been made in the project that involve new significant environmental effects or a substantial increase in the severity of previously identified significant effects; no substantial changes have occurred in the circumstances under which the project is being undertaken, that involve new significant environmental effects or a substantial increase in the severity of previously identified environmental effects; and no new information of substantial importance to the project which was not known or could not have been known when Final EIR 589, Addendum 1.0, Addendum 1.1, and the Planning Area 2 Addendum were certified and approved has become known; therefore, no further environmental review is required.
 - b. Final EIR 589, Addendum 1.0, Addendum 1.1, the Planning Area 2 Addendum, and Addendum 3.1 are adequate to satisfy the requirements of CEQA for VTTM19108.
 - c. All mitigation measures are fully enforceable pursuant to Public Resources Code section 21081.6(b) and have either been adopted as conditions, incorporated as part of the project design, or included in the procedures of project implementation.
- 3) Approve VTTM19108, subject to the attached Findings and Conditions of Approval.

NOTE: Per State Law, for any improvements required prior to the recordation of a final map, the developer may instead enter into an agreement with the County of Orange guaranteeing all required improvements. Said agreement shall be accompanied by financial security.

BACKGROUND AND EXISTING CONDITIONS:

In November 2004, the County of Orange approved the Ranch Plan Planned Community, which encompasses approximately 22,815 acres located east of I-5, north and south of Ortega Highway at Antonio Parkway/La Pata Avenue, within the Fifth Supervisorial District. (The Ranch Plan Planned Community Exhibit, page 3). As approved, the Ranch Plan Planned Community encompasses 75 percent permanent open space, with development of 14,000 dwelling units and 5,200,000 square feet (SF) of non-residential uses allowed within the remaining 25 percent. It is regulated by the Ranch Plan PC Program Text which addresses the unique characteristics of the property and a development plan for the transition to suburban/urban uses occurring over a 25 to 30-year period.

Currently, Planning Area 1.1 of the Ranch Plan is complete. The Master Area Plan (PA130006) and Subarea Plans (PA130001 - PA130004) for Planning Area 2 were approved on March 27, 2013. PA2 Master Area and Subarea Plan Amendments (PA150047) were approved May 22, 2017 as part of a comprehensive reallocation. The reallocation resulted in a reduction of PA2 total dwelling units from 3,291 to 2,700, as

well as minor changes to PA2 Mater Area and Subarea boundaries. Final Tract Map 17563 for Subarea 2.3 was approved on October 11th by the County of Orange Board of Supervisors and was recorded on October 18th. Currently, Subarea 2.3 is being developed with several Builder phases under construction.

The proposed project site for “B” Vesting Tentative Tract Map 19108 was originally approved by the County of Orange Board of Supervisors as a portion of Tract 17596 on September 26, 2017. Tract 17596 included 72 legal lots; 56 numbered lots for conventional single-family detached dwellings, 1 numbered lot for a neighborhood landscaped paseo, and 15 lettered lots for slopes and landscaped areas. Subsequently, the Board of Supervisors approved Tract 17605 on November 19, 2019; the map recorded on January 28, 2020. Tract 17605 comprised the northern half of Tract 17596, including the current project site. Approved under Tract 17605 were 70 legal lots; 62 numbered lots for conventional single-family detached dwellings, 1 numbered lot for a neighborhood pocket park, and 7 lettered lots for slopes and landscaped areas. The proposed project site for “B” Vesting Tentative Tract Map 19108 is essentially the midpoint between Tract 17596 and Tract 17605, and includes Lots 24 through 33 of Tract 17605. The project site has been rough graded and street improvements have been constructed; however, new construction permits will be required to address the new tract configuration.

Proposed Project

The Applicant, The New Home Company, requests approval of “B” Vesting Tentative Tract Map 19108 (VTTM 19108) to subdivide a 1.21-acre site within Subarea 2.3 of the Ranch Plan Planned Community into 9 legal lots; 7 numbered lots for conventional single-family detached dwellings, 1 numbered lot for a neighborhood pocket park, and 1 lettered lot for landscaped area.

SURROUNDING LAND USE:

Land uses immediately surrounding the project site include the following:

- North: Single-family homes by New Home Company (Tract 17605)
- East: Single-family homes by New Home Company (Tract 17605), Medano Street
- South: Single-family homes by New Home Company (Tract 17596)
- West: Esencia Drive, Esencia sports park, single-family homes by Pulte Homes (Tract 17597)

Please refer to the General Vicinity Map on this page and the PA2.3 Builder Map on page 4.

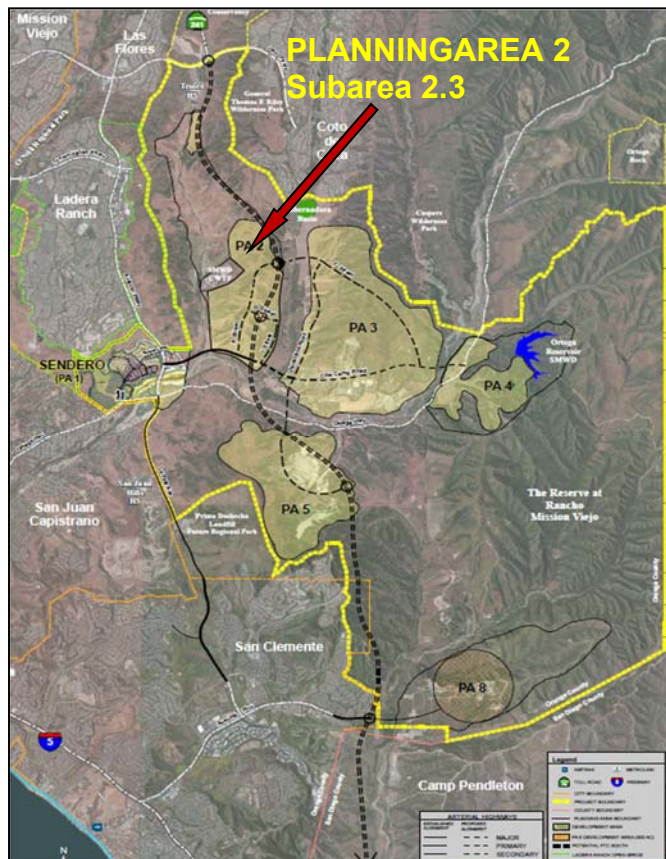

Exhibit 1 - General Vicinity Map

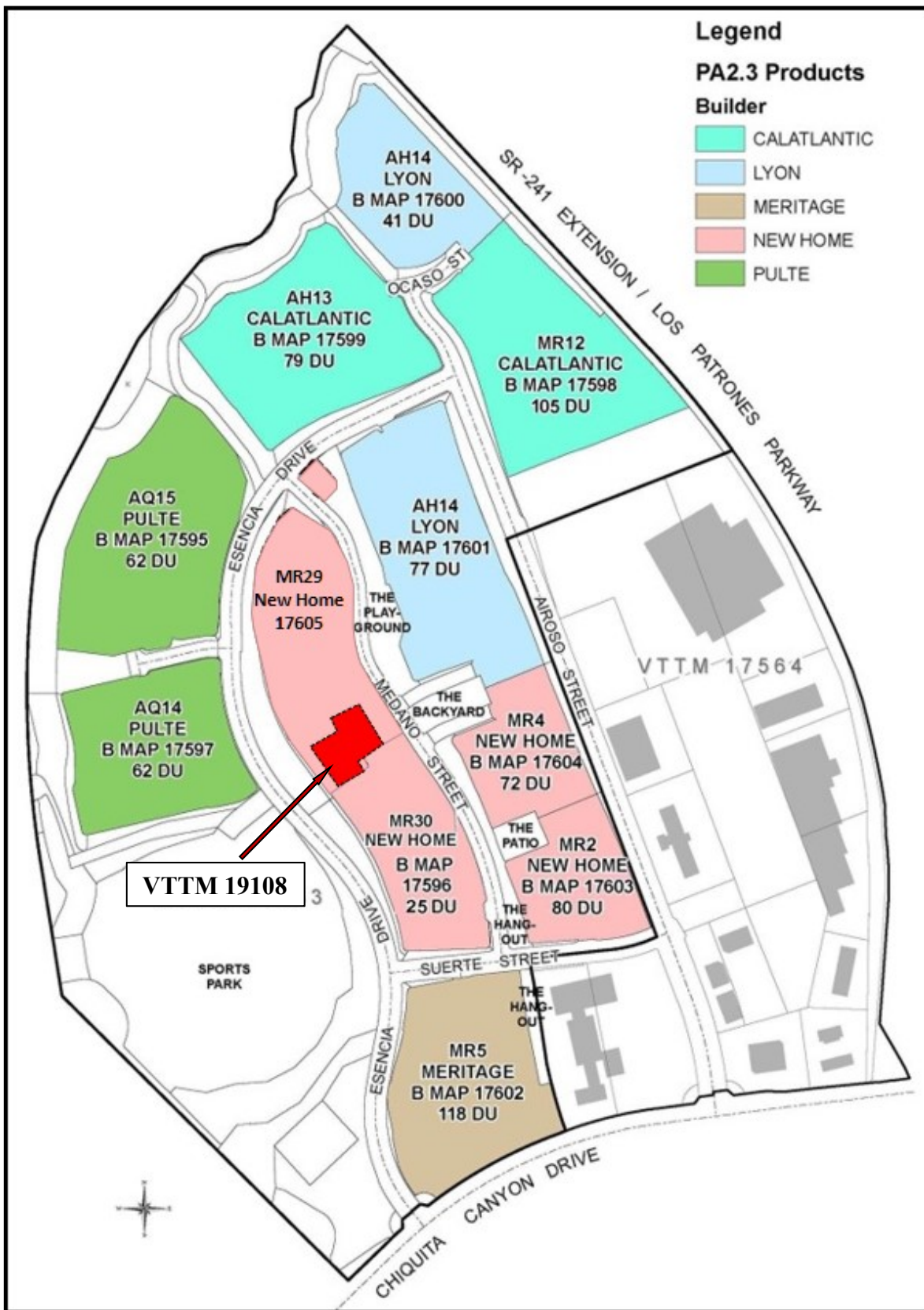

Exhibit 2 – PA2.3 Builder Map

General Description

The proposed “B” VTTM 19108 is a subdivision of a 1.21-acre site within Subarea 2.3 of the Ranch Plan Planned Community into 9 legal lots; 7 numbered lots for conventional single-family detached dwellings, 1 numbered lot (Lot 4) for a neighborhood pocket park, and 1 lettered lot (Lot A) for a landscaped area with access to the tract provided from Topaz Street. The tract map is a suburban cul-de-sac configuration designed to accommodate single-family detached homes with front-loaded garages. The existing internal street, Topaz Street, will be reconfigured into two abutting cul-de-sac streets. The northerly section of Topaz Street is to be renamed prior to Final Map recordation.

As previously discussed, the project site was formerly recorded as a portion of Tract 17650, a subdivision that created 70 legal lots; 62 numbered lots for conventional single-family detached dwellings, 1 numbered lot for a neighborhood pocket park and 7 lettered lots for slopes and landscaped areas. The project site has been rough graded, and street and storm drain improvements have been completed; however, no further construction has occurred on the residential lots. Proposed “B” VTTM 19108 is located on Lots 24 through 33 of Tract 17605. Under proposed VTTM 19108, the quantity of numbered lots for the project site would decrease from 10 lots to 8 lots. The purpose for decreasing the number of lots is to allow for a reconfiguration of Topaz Street. Topaz Street is proposed to be reconfigured within the project site from a through street to two adjacent termini of cul-de-sacs. The southern cul-de-sac street will remain as Topaz Street. The northern cul-de-sac will be renamed prior to Final Map recordation through coordination with Orange County Fire Authority and Orange County Sheriff Division

The reconfiguration of Topaz Street will create a vehicular traffic boundary between the original subdivision of Tract 17596 and the subsequent subdivision of Tract 17605. The reconfiguration will also serve to distinguish the two different residential housing products being developed for Tract 17605 and Tract 17596. Lots 1, 2, 5, 6, and 7 of VTTM 19108 will be accessed from the northern cul-de-sac street, through Tract 17605. Lot 3 and Lot 4 (neighborhood pocket park) of VTTM 19108 will be accessed from the southern cul-de-sac street (Topaz Street), through Tract 17596. Pedestrian circulation will not be impeded as the dual cul-de-sacs provide continuous sidewalks between Tracts 17596 and 17605.

All proposed lots for VTTM 19108 will still meet the minimum required building site area of 3,000 square feet, per the Ranch Plan PC Text Section III.A.1 (Conventional Single-Family Detached Dwellings). The smallest lot proposed within VTTM17605 will measure 3,973 square feet. Upon approval of VTTM 19108, the applicant will be required to obtain new construction level permits for the project site consistent with the new tract layout.

Consistency Analysis:

The proposed “B” Vesting TT19108 is consistent with:

- a. General Plan – The County of Orange General Plan Land Use Element designates Subarea 2.3 of Ranch Plan as “1B, Suburban Residential (0.5 to 18 du/ac)”, per GPA 01-01. The proposed map is consistent with the 1B “Suburban Residential designation.
- b. Zoning: Planned Community. The proposed map is in conformance with the County of Orange Planned Community District regulations as regulated by the Ranch Plan Planned Community Text, statistical summary, and development maps. The proposed map is consistent with the PA2 Master Area Plan (PA130006), Subarea Plan 2.3 (PA130003), and the PA2 Master Area and Subarea Plan Amendments (PA150047, PA180029).
- c. State Subdivision Map Act and County of Orange Subdivision Code and Manual

- d. CEQA – VTTM 19108 is consistent with Program EIR 589, which was certified on November 8, 2004; Addendum 1.0 (PA060023) approved on July 26, 2006; Addendum 1.1 (PA110003-06) approved on February 24, 2011; the Planning Area 2 Addendum (PA13-0006) approved on March 27, 2013; and Addendum 3.1 (PA140072-81) approved February 25, 2015
- e. Alternative Development Standards – All previously approved Alternative Development Standards that are to be incorporated into the development of this project are listed under Note #17 on the cover page of the proposed VTTM 19108.
- f. Regulation Compliance Matrix – Clearance of all applicable conditions of approval have been confirmed per the Ranch Plan Regulation Compliance Matrix.

The Ranch Plan PC Statistical Table

The purpose of the Planned Communities (PC) Statistical Table is to provide for the detailed breakdown of development statistics by individual Planning Areas. It identifies the gross acreage, the maximum number of permitted dwelling units, the maximum acres of residential and non-residential uses, and the minimum acres of open space required for each Planning Area. The development parameters for Planning Area 2 were originally established by the PC Statistical Table approved by the Planning Commission on March 27, 2013 as part of the PA2 Master Area Plan (PA130006). Subsequent PC Statistical Tables were approved by the Planning Commission on February 25, 2015 as part of the PA3 and PA4 Master Area Plan (PA140072) and by the Deputy Director, OC Development Services on May 22, 2017 as part of a comprehensive reallocation that included Planning Areas 1 through 4 (PA150047). The latest version of the PC Statistical Table was approved by the Deputy Director, OC Development Services on November 12, 2019 as part of administrative revisions to Planning Areas 1 and 2 (PA180029).

The previously approved “A” tentative tract maps for Subareas 2.1 through 2.4 (VTTM17561 through VTTM17564) were determined to be consistent with the gross acreage, the maximum permitted acres of residential and non-residential uses, and the minimum acres of open space required for Planning Area 2.

This latest version of the PC Statistical Table indicates a maximum of 2,760 dwelling units are permitted within Planning Area 2. Table 1 below identifies the total number of dwelling units that have been approved within Subareas 2.1, 2.2, and 2.3 under multiple “B” tract maps, and within Subarea 2.4 under Site Development Permit PA19-0103. The proposed VTTM 19108 is identified in italicized text.

Table 1

Planning Area 2

Approved and Proposed Dwelling Units

Location	Dwelling Units
Subarea 2.1	990 (approved)
Subarea 2.2	878 (approved)
Subarea 2.3	774 (approved)
<i>Subarea 2.3, TT19108</i>	<i>7 (proposed)</i>
Subarea 2.4	92 (approved)
Planning Area 2 Total	2,741

As reflected in Table 1, the total approved and proposed dwelling units within Planning Area 2 is below the 2,760 maximum permitted dwelling units allowed by the PC Statistical Table. Therefore, the proposed VTTM19108, as well as all other approved residential development within PA2.3, are consistent with the current Ranch Plan PC Statistical Table.

Estimated Earthwork

The proposed estimated grading quantities for this map are substantially consistent with or less than the earthwork quantities described under previous approvals (i.e. Master Area Plan (PA2), Subarea Plan 2.3, Tract 17563, and related grading permits GA150006 and GA150007.

Estimated Earthwork

The proposed estimated grading quantities for this map are substantially consistent with or less than the earthwork quantities described under previous approvals (i.e. Master Area Plan (PA2), Subarea Plan 2.3, Tract 17563, and related grading permits GA150006 and GA150007.

Drainage:

The subject property is in the Ranch Plan Planned Community Runoff Management Plan Area and is within the approved Master Plan of Drainage (MPD) for Subareas 2.3 and 2.4. The MPD does not identify any storm drain facilities within VTTM19108. There are no MPD fees required for this map.

Recreation and Open Space:

The proposed map is not required to provide any improvements or dedications associated with the County Master Plan of Regional Recreation Facilities; Master Plan of Regional Riding and Hiking Trails; Resources Element (Open Space Component); or OCTA Strategic Plan for Bikeways.

- Master Plan of Regional Recreation Facilities - There are no regional park dedication requirements of the subject map.
- Master Plan of Regional Riding and Hiking Trails - There are no riding and hiking trail requirements of the subject map.
- Master Plan of Local Parks (Local Park Code) - The proposed map is required to provide park land in accordance with the Master Plan of Local Parks (Local Park Code). Said requirement is satisfied by an allocation of parkland credit from Park Modification PM07-01, the Local Park Implementation Plan (LPIP) for the Ranch Plan P.C. originally approved March 14, 2007, 1st Amendment approved in June 2012, 2nd Amendment approved on July 16, 2014. and 3rd Amendment approved on November 7, 2019.

Per the Ranch Plan LPIP, the total parkland acreage requirement for the entire Ranch Plan Planned Community is 96 acres, based on 14,000 approved dwelling units and the anticipated proportion of single-family and multi-family units. The Ranch Plan LPIP indicates 7.8 acres (public park facilities) of the 96-acre total parkland will be required in PA2, Subarea 2.3, based on the 2,760 dwelling units entitled by the PA2 Master Area Plan PA130006, per the parkland generation factor for each unit (greater than 6.5 du/ac requires 0.006 acres and less than 6.5 du/ac requires 0.008 acres). Rancho Mission Viejo's Final Tract Map 17563 for Subarea 2.3 was recorded with 21.846 acres of dedicated public park land (FM 17563, Lots 42-44) and 4.793 acres of private recreation facilities (FM 17563, Lots 38-41, 45), which is in compliance with the current LPIP. Therefore, the park requirements for PA2 Subarea 2.3 identified in the Ranch Plan LPIP have been met.

- Resources Element - Open Space Component - There are no open space dedication requirements of the subject map.
- OCTA Strategic Plan for Bikeways - There are no County-wide bikeways identified within the boundaries of this map.

Public Services & Utilities

- Schools - This property is within the boundaries of the Capistrano Unified School District. The developer is subject to the provisions of Assembly Bill AB 2926, or other mitigating measures designed to provide for school facilities and/or funding, such as community facilities districts.
- Facilities Fees Programs - This project area is included within the Ranch Plan Planned Community Development Agreement which phases development commensurate with public services and facilities.
- Water/Sewer - This project is within the boundaries of the Santa Margarita Water District. The District stated in their Preliminary Water and Sewer letter dated May 29, 2020, that the District will be capable of providing water and sewage disposal service to this development.
- Water Quality Control - This project will be required to operate in accordance with requirements prescribed by the California Regional Water Quality Control Board, San Diego Region.
- Fire Protection and Safety - Existing and proposed fire protection services will provide an adequate level of fire protection services to this development, per the TT19108 Fire Master Plan approved by OCFA May 13, 2020 (SR #288348). Additionally, this property is within the area covered by the approved Ranch Plan Fire Protection Program, which includes all applicable conditions of approval and regulations.
- County Service Area (CSA) - This property is within the boundaries of County Service Area No. 26.

Traffic/Circulation

- Scenic Highway Corridors - There are no Scenic Highways applicable to this map.
- Access/Highways/Streets/Roads - Access to the site and internal access will be provided by Topaz Street, a future proposed public street.
- Major Thoroughfare and Bridge Fee Program - This project lies within the area of benefit of the Foothill/Eastern Transportation Corridor. The developer is required to pay Foothill/Eastern Major Thoroughfare and Bridge fees in accordance with the adopted program.
- Off-Site Fee Program – The project lies within the area of benefit of the South County Roadway Improvement Road Fee Program (SCRIP). The developer is required to pay SCRIP fees in accordance with the adopted program.

Multiple Final Map Phasing

As indicated on the Map under Note #13 of the title sheet VTTM 19108, the option of multiple final maps phasing has been requested as part of the approval of this Vesting Tentative Tract Map.

DEVIATIONS FROM STANDARDS OF DESIGN:

The developer may request deviations from County standard design criteria in accordance with Subdivision Code section 7-9-291. In the absence of any specifically approved deviation request, the County-approved standard design criteria will prevail. No deviations are requested with this map.

ALTERNATIVE DEVELOPMENT STANDARDS:

As allowed by General Regulation #25 of the Ranch Plan Planned Community Program Text, proposed Alternative Development Standards are intended to be incorporated into the development as listed within the “Notes” portion of the cover page of VTTM 19108. The following approved Ranch PC Alternative Development Standards (approved July 24, 2013) are proposed as part of VTTM 19108:

- A-20 Alternative Neighborhood Sidewalk Detail Curb-Separated Walkway
- D-11 Single Family Detached On-Street Parking

REFERRAL FOR COMMENT AND PUBLIC NOTICE:

Copies of the tentative map application submittal package were distributed for review and comment to County staff and consultants, including Land Development, OC Infrastructure Programs, Inspection Services, Building & Safety, OC Survey, and Orange County Fire Authority. Through focused coordination meetings and a collaborative effort with County staff, the applicant adequately addressed all comments. As of the writing of this staff report, no further comments have been received by any County divisions.

A Notice of Public Hearing was mailed to all property owners of record within 300 feet of the subject site on July 1, 2020. Additionally, notices were posted at the site, at the Orange County Hall of Administration, at the County Administrations South (CAS) Building, and on the Orange County Public Works website as required by established public hearing posting procedures. No public comments have been received to date.

CEQA COMPLIANCE:

The proposed project is covered by previous CEQA documentation, which includes Final Program EIR 589, which was certified on November 8, 2004; Addendum 1.0 approved on July 26, 2006; Addendum 1.1 approved on February 24, 2011; the Planning Area 2 Addendum approved on March 27, 2013; and Addendum 3.1 approved February 25, 2015. This finding is appropriate and complies with the intent of CEQA, pursuant to the 2014 Orange County Local CEQA Procedures Manual, Sections VI & XI, Appendix G for projects where a previous environmental document (i.e. Program EIR 589) is already in place. Further CEQA evaluation and clearances are not required for proposed “B” VTTM 19108.

CONCLUSION:

Based upon a review of the subject submittal, staff supports approval of the applicant’s proposed “B” Vesting Tentative Tract Map 19108 (VTTM 19108) pursuant to the Orange County Subdivision Code, Orange County Codified Ordinances (OCCO) Subarticle 5 (Processing Procedures for Tentative Maps).

Submitted by:

Bea Bea Jiménez, Division Manager, Land Development
OC Development Services

CERTIFICATION:

I hereby certify that Vesting Tentative Tract Map 19108 was approved by the Orange County Subdivision Committee on July 15, 2020, per the findings in Appendix A and the conditions in Appendix B.

Richard Vuong, Interim Deputy Director
OC Development Services

APPENDICES:

- A. Recommended Findings
- B. Recommended Conditions of Approval
- C. Ranch Plan Regulation Compliance Matrix - “B” Map Items

ATTACHMENTS:

- 1. Applicant’s Letter of Proposal
- 2. Project Site Exhibit
- 3. Will Serve Letter
- 4. Project Plans and Fire Master Plan

APPEAL PROCEDURE:

Any interested person may appeal the decision of the Subdivision Committee on this application to the Orange County Planning Commission within 15 calendar days of the decision upon submittal of required documents and a filing deposit of \$500.00 filed at the County Administration South (CAS) Building, 601 North Ross Street, Santa Ana. If you challenge the action taken on this proposal in court, you may be limited to raising only those issues you or someone else raised in written correspondence delivered to OC Development Services.

APPENDIX A



Appendix A Findings TT19108

1	EIR AND ADDENDUM	TT19108 (Custom)
<p>That the decision-maker has considered Final EIR 589, previously certified on November 8, 2004; Addendum 1.0 (PA060023) approved July 2006; Addendum 1.1 (PA110002-PA110006) approved February 24, 2011; the Planning Area 2 Addendum (PA130001-PA130004 and PA130006) approved on March 27, 2013; and Addendum 3.1 (PA140072-81) approved February 25, 2015 prior to project approval:</p> <p>a. Together, these documents reflect the independent judgment of the County and satisfy the requirements of CEQA for approval of VTTM19108, which is a necessarily included element contemplated as part of the whole of the action considered in Final EIR 589, Addendum 1.0, Addendum 1.1, the Planning Area 2 Addendum, and Addendum 3.1;</p> <p>b. The circumstances of the project are substantially the same as described in Final EIR 589, Addendum 1.0, Addendum 1.1, the Planning Area 2 Addendum, and Addendum 3.1 which adequately addressed the effects of the project proposed in VTTM19108. No substantial changes have been made in the project that involve new significant environmental effects or a substantial increase in the severity of previously identified significant effects; no substantial changes have occurred in the circumstances under which the project is being undertaken, that involve new significant environmental effects or a substantial increase in the severity of previously identified environmental effects; and no new information of substantial importance to the project which was not known or could not have been known when Final EIR 589, Addendum 1.0, Addendum 1.1, the Planning Area 2 Addendum, and Addendum 3.1 were certified and approved has become known; therefore, no further environmental review is required.</p> <p>c. All mitigation measures are fully enforceable pursuant to Public Resources Code section 21081.6(b) and have either been adopted as conditions, incorporated as part of the project design, or included in the procedures of project implementation.</p>		
2	ENVIRONMENTAL MONITORING	TT19108 (Custom)
<p>That the monitoring requirements of Public Resources Code Section 21081.6 (AB 3180) will be considered as having been met in that the design of the subject project, the satisfaction of the requirements of the County's building, grading, fire, and other codes and ordinances and the satisfaction of the conditions of approval applied to the project will implement the mitigation measures contained in EIR No. 589, Addendum 1 (PA06-0023), Addendum 1.1 (PA110003-0006), the Planning Area 2 Addendum (PA130001-0004 and PA130006), and Addendum 3.1 (PA140072-81).</p>		
3	GENERAL PLAN CONSISTENCY	TT19108
<p>That the proposed map is consistent with the Orange County General Plan.</p>		
4	DESIGN & IMPROVEMENT	TT19108
<p>That the design and improvement of the proposed subdivision are consistent with the Orange County General Plan.</p>		
5	DEVELOPMENT TYPE	TT19108
<p>That the proposed site is physically suitable for the proposed type of development.</p>		
6	DEVELOPMENT DENSITY	TT19108
<p>That the proposed site is physically suitable for the proposed density of development.</p>		
7	ENVIRONMENTAL DAMAGE	TT19108
<p>That the design of the subdivision or the proposed improvements are not likely to cause substantial environmental damage or substantial and avoidable injury to fish or wildlife or their habitat.</p>		
8	PUBLIC HEALTH	TT19108
<p>That the design of the subdivision and the type of improvements proposed are not likely to cause serious public health problems.</p>		
9	PUBLIC EASEMENTS	TT19108
<p>That the design of the subdivision and the type of improvements proposed will not conflict with easements of record or established by court judgment acquired by the public-at-large for access through or use of property within the proposed subdivision.</p>		
10	SUBDIVISION / ZONING CODE CONSISTENCY	TT19108
<p>That the proposed subdivision complies with the requirements set forth in the Orange County Subdivision Code and the Orange County Zoning Code.</p>		
11	ZONING CONSISTENCY	TT19108
<p>That the design and improvement of the proposed subdivision are suitable for the uses proposed, and the subdivision can be developed in compliance with applicable zoning regulations pursuant to Section 7-9-254 of the Subdivision Code.</p>		
12	SEWER SYSTEM	TT19108 (Custom)
<p>That the discharge of waste from the proposed subdivision into the existing sewer system of the Water District will not result in violations of existing requirements prescribed by the California Regional Water Quality Control Board, San Diego Region.</p>		
13	NATURAL HEATING AND COOLING	TT19108
<p>That the design of the subdivision and its improvements do provide, to the extent feasible, for future passive or natural heating or cooling opportunities as specified in Section 66473.1 of the Government Code (Subdivision Map Act).</p>		
14	FEE PROGRAMS	TT19108
<p>That the following determinations apply to fees required by Sections 7-9-700 through 713, Codified Ordinances of Orange County:</p> <p>A. Purpose of fees: Fire protection, paramedic, law enforcement, library, and general County services.</p> <p>B. Use of fees: Construction of new fire station, sheriff substation, library, and general County facilities in newly developing areas which have inadequate service.</p> <p>C. Relationship between use of fees and type of development: Dwelling units and commercial/industrial structures and their occupants require fire protection, paramedic, law enforcement, library, and general County services.</p>		

D. Relationship between need for facilities and type of project: Project is located in newly developing area which has inadequate fire protection, paramedic, library services, and sheriff substation and general County facilities.

E. Relationship between amount of fees and cost of the portion of the facilities attributable to the development: Fees represent project's pro rata share of the cost of the fire station, sheriff substation, library, and general County facilities.

15

EXPIRATION OF MAPS

TT19108

That because of participation in fee programs for off-site improvements, this project will qualify for consideration under Section 66452.6 of the Subdivision Map Act.

16

LOCAL PARK CODE

TT19108 (Custom)

That the Local Park Code requirement can be met by an allocation of park lands credit from PM 07-01, the park implementation plan for the Ranch Plan Planned Community.

17

DEVELOPMENT AGREEMENT

TT19108

That the Development Agreement contains provisions requiring developer participation in fee programs, facility construction and development phasing and is therefore in compliance with the adopted Growth Management Element in terms of public services and facilities being made available to accommodate development.

18

APPEAL OF EXACTIONS

TT19108

That the applicant is hereby provided notice that the fees, dedications, reservations or other exactions imposed on this project are as described in this approval as well as the reports and actions accompanying this approval and that the 90-day approval period in which the applicant may protest pursuant to Government Code Section 66020 has begun.

APPENDIX B



Appendix B Conditions of Approval TT19108

1 RANCH PLAN REGULATION COMPLIANCE MATRIX TT19108 (Custom)

The applicant shall comply with all applicable requirements of the Ranch Plan Regulation Compliance Matrix: to the satisfaction of the appropriate decision maker listed in each applicable Regulation Compliance Matrix item. The applicable requirements are listed below and attached as Appendix C:

a. Prior to Recordation:

- 139: EIR 589 Mitigation Measure 4.9-27 – Invasive Plants CC&R Prohibition
- 524: EIR 589 Stand. Cond. 4.4-3 (G04) – Off-site Letter of Consent (if necessary)
- 527 & 527.1: EIR 589 Standard Condition 4.5-1 (D01a) – Drainage Study
- 528 & 528.1: EIR 589 Standard Condition 4.5-2 (D02a) – Drainage Improvements
- 529: EIR 589 Standard Condition 4.5-2 (D02a) – Drainage Improvements
- 532: EIR 589 Standard Condition 4.5-4 (D04b) – Master Plan of Drainage
- 533: EIR 589 Standard Condition 4.5-5 (D06b) – Subordination of Easements
- 534: EIR 589 Standard Condition 4.5-5 (D06b) – SMWD Easements
- 535: EIR 589 Standard Condition 4.5-6 (D07b) – Regional Facility Improvements
- 537 & 537.1: EIR 589 St. Cond. 4.5-8 (WQ01) – Water Quality Management Plan (WQMP)
- 538: EIR 589 St. Cond. 4.5-8 (WQ03) – Water Quality Management Plan (WQMP)
- 544: EIR 589 Standard Condition 4.6-2 (T01) – Vehicular Access Rights
- 545: EIR 589 Standard Condition 4.6-3 (T02) – Private Street Improvements
- 546: 546.1: 546.2 & 546.3: SC 4.6-4: (T04) – Street Improvements
- 549: EIR 589 Standard Condition 4.6-7 (T08) – Traffic Signal Conduit
- 550, 550.1, 550.2 & 550.3: EIR 589 Stand. Cond. 4.6-8 (T12) – Internal Circulation
- 551: EIR 589 Standard Condition 4.6-9 (T13b) – Traffic Signal Maintenance Easement
- 552: EIR 589 Standard Condition 4.6-10 (T14b) – Traffic Signal Installation
- 559 & 559.1: EIR 589 Standard Condition 4.8-3 (N01) – Sound Attenuation
- 589.1: EIR 589 Standard Condition 4.15-1 – Water Improvement Plans
- 597: EIR 589 Standard Condition 4.15-9 – Capistrano Unified School District fees
- 619: Ranch Plan Fire Prot. Program Cond. 4 – OCFA Administrative Approval

b. Prior to Approval of Site Development Permit

- 109: EIR 589 Mitigation Measure 4.7-3 – Shade Trees in Parking Lot Design
- 110: EIR 589 Mitigation Measure 4.7-3 – Use of Light-Colored Roof Materials

c. Prior to Issuance of Grading Permits

- 521: EIR 589 Standard Condition 4.4-1 (G01) – Geotechnical report
- 522: EIR 589 Standard Condition 4.4-2 (G02) – Conformance with TT Map
- 523: EIR 589 Standard Condition 4.4-2 (G02) – Revised TT Map (if necessary)
- 524: EIR 589 Stand. Cond. 4.4-3 (G04) – Off-site Letter of Consent (if necessary)
- 525: EIR 589 Standard Condition 4.4-4 (G09) – Consistency with Planning Approval
- 527 & 527.1: EIR 589 Standard Condition 4.5-1 (D01a) – Drainage Study
- 528 & 528.1: EIR 589 Standard Condition 4.5-2 (D02a) – Drainage Improvements
- 530 & 530.1: EIR 589 Standard Condition 4.5-3 (D02b) – Drainage Improvements
- 537 & 537.1: EIR 589 St. Cond. 4.5-8 (WQ01) – Water Quality Management Plan (WQMP)
- 538: EIR 589 St. Cond. 4.5-8 (WQ03) – Water Quality Management Plan (WQMP)
- 540: EIR 589 St. Cond. 4.5-10 (WQ04) – Stormwater Pollution Prevention (SWPPP)
- 541: EIR 589 St. Cond. 4.5-11 (WQ05) – Erosion and Sediment Control Plan
- 548: EIR 589 Standard Condition 4.6-6 (T07) – Sight Distance
- 555, 555.1 through 555.5: EIR 589 Standard Condition 4.7-1 – Fugitive Dust
- 556, 556.1, 556.2 & 556.3: EIR 589 Standard Condition 4.7-2 – Emission Control
- 557: EIR 589 Standard Condition 4.8-1 (N10) – Hours of Construction
- 558, 558.1, 558.2, 558.3 & 558.4: EIR 589 St. Condition. 4.8-2 (N10) – Construction Noise
- 559 & 559.1: EIR 589 Standard Condition 4.8-3 (N01) – Sound Attenuation
- 567: EIR 589 Standard Condition 4.10-2 (LA02b) – Private Area Landscaping
- 571: EIR 589 Standard Condition 4.11-1 (A04) – Archaeology Grading Observation and Salvage
- 574: EIR 589 Standard Condition 4.11-2 (A07) – Paleontology Resource Surveillance
- 589: EIR 589 Standard Condition 4.14-2 – Hazardous Materials
- 616: Ranch Plan Fire Prot. Program Cond. 3.d. – Precise Fuel Modification Plan

d. Prior to Precise Fuel Modification Plans:

- 138: EIR 589 Mitigation Measure 4.9-27 – Invasive Plants and Fuel Modification

e. Prior to Issuance of Building Permit:

- 111: EIR 589 Mitigation Measure 4.7-3 – Use of Light-Colored Roof Materials
- 140: EIR 589 Mitigation Measure 4.9-28 – Open Space habitat, light shields
- 206: EIR 589 Mitigation Measure 4.15-5 – Capistrano Unified School District fees
- 526: EIR 589 Standard Condition 4.4-5 – Compliance with Code
- 537 & 537.1: EIR 589 St. Cond. 4.5-8 (WQ01) – Water Quality Management Plan (WQMP)
- 538: EIR 589 St. Cond. 4.5-8 (WQ03) – Water Quality Management Plan (WQMP)
- 540: EIR 589 St. Cond. 4.5-10 (WQ04) – Stormwater Pollution Prevention (SWPPP)
- 541: EIR 589 St. Cond. 4.5-11 (WQ05) – Erosion and Sediment Control Plan
- 547: EIR 589 Standard Condition 4.6-5 (T05) – Major Thoroughfare & Bridge Fees
- 550, 550.1, 550.2 & 550.4: EIR 589 Standard Condition 4.6-8 (T12) – Internal Circulation
- 559.2 & 559.3: EIR 589 Standard Condition 4.8-3 (N01) – Sound Attenuation
- 564 & 564.1: EIR 589 Standard Condition 4.10-1 (LA01b) – Public Area Landscaping
- 570: EIR 589 Standard Condition 4.10-3 (LG01) – Light and Glare
- 589: EIR 589 Standard Condition 4.14-2 – Hazardous Materials
- 617: Ranch Plan Fire Prot. Program Cond. 3.e. – Vegetation Clearance

f. Prior to Combustible Construction:

609: Ranch Plan Fire Prot. Program Cond. 2.d. – Emergency Access & Water Supply

g. During Construction:

197: EIR 589 Mitigation Measure 4.14-13 – ESA Remedial Measures

h. Prior to Certificates of Occupancy:

529: EIR 589 Standard Condition 4.5-2 (D02a) – Drainage Improvements

531: EIR 589 Standard Condition 4.5-3 (D02b) – Drainage Improvements

539, 539.1 & 539.2: EIR 589 Standard Condition 4.5-9 (WQ03) – Compliance with Water Quality Management Plan (WQMP)

560: EIR 589 Standard Condition 4.8-4 (N09) – Multi-Family Residential Development

563: EIR 589 Standard Condition 4.8-7 (N12) – Transportation Corridor Notification

565 & 566: EIR 589 Standard Condition 4.10-1 (LA01b) – Public Area Landscaping

568 & 569: EIR 589 Standard Condition 4.10-2 (LA02b) – Private Area Landscaping

618: Ranch Plan Fire Prot. Program Cond. 3.f. - Fuel Modification Zones

i. Prior to Release of Grading Bond:

572 & 573: EIR 589 Standard Condition 4.11-1 (A04) – Archaeology Grading Observation and Salvage

575 & 576: EIR 589 Standard Condition 4.11-2 (A07) – Paleontology Resource Surveillance

2 WATER QUALITY MANAGEMENT PLAN TT19108

Prior to the issuance of any grading or building permits, the applicant shall submit for review and approval by the Manager, Permit Services, a Water Quality Management Plan (WQMP) specifically identifying Best Management Practices (BMPs) that will be used onsite to control predictable pollutant runoff. The applicant shall utilize the Orange County Drainage Area Management Plan (DAMP), Model WQMP, and Technical Guidance Manual for reference, and the County's WQMP template for submittal. This WQMP shall include the following:

- Detailed site and project description
- Potential stormwater pollutants
- Post-development drainage characteristics
- Low Impact Development (LID) BMP selection and analysis
- Structural and Non-Structural source control BMPs
- Site design and drainage plan (BMP Exhibit)
- GIS coordinates for all LID and Treatment Control BMPs
- Operation and Maintenance (O&M) Plan that (1) describes the long-term operation and maintenance requirements for BMPs identified in the BMP Exhibit; (2) identifies the entity that will be responsible for long-term operation and maintenance of the referenced BMPs; and (3) describes the mechanism for funding the long-term operation and maintenance of the referenced BMPs

The BMP Exhibit from the approved WQMP shall be included as a sheet in all plan sets submitted for plan check and all BMPs shall be depicted on these plans. Grading and building plans must be consistent with the approved BMP exhibit.

3 BEST MANAGEMENT PRACTICES TT19108 (Custom)

Prior to issuance of a building permit, the off-site regional Best Management Practices (BMPs) relied upon by this project (e.g., basins, swales, etc.) must be built and/or installed, and operational. The location and operation of these regional BMPs must be in compliance with the Final Project-Specific WQMP for the regional BMP(s). The location and operation of the regional BMP(s) must be demonstrated to the satisfaction of the Manager, Grading and Building Plan Check.

4 COMPLIANCE WITH THE NPDES IMPLEMENTATION PROGRAM TT19108

Prior to the issuance of a certificate of use and occupancy, the applicant shall demonstrate compliance with the County's NPDES Implementation Program in a manner meeting the satisfaction of the Manager, OC Inspection, including:

- Demonstrate that all structural Best Management Practices (BMPs) described in the BMP Exhibit from the project's approved WQMP have been implemented, constructed and installed in conformance with approved plans and specifications
- Demonstrate that the applicant has complied with all non-structural BMPs described in the project's WQMP
- Submit for review and approval an Operations and Maintenance (O&M) Plan for all structural BMPs (the O&M Plan shall become an attachment to the WQMP);
- Demonstrate that copies of the project's approved WQMP (with attached O&M Plan) are available for each of the initial occupants;
- Agree to pay for a Special Investigation from the County of Orange for a date twelve (12) months after the issuance of a Certificate of Use and Occupancy for the project to verify compliance with the approved WQMP and O&M Plan
- Demonstrate that the applicant has RECORDED one of the following:
 1. The CC&R's (that must include the approved WQMP and O&M Plan) for the project's Home Owner's Association;
 2. A water quality implementation agreement that has the approved WQMP and O&M Plan attached; or
 3. The final approved Water Quality Management Plan (WQMP) and Operations and Maintenance (O&M) Plan. (Appendix C - Items 539, 539.1, 539.2)

5 INDEMNIFICATION TT19108 (Custom)

Applicant shall defend with counsel approved by the County of Orange in writing, indemnify and hold harmless the County of Orange, its officers, agents and employees from any claim, action or proceeding against the County, its officers, agents or employees to attack, set aside, void, or annul any approval of the application or related decision, or the adoption of any environmental documents, findings or other environmental determination, by the County of Orange, its Board of Supervisors, Planning Commission, Zoning Administrator, Director of OC Public Works, or Director of Planning concerning this application. The County may, at its sole discretion, participate in the defense of any action, but such participation shall not relieve applicant of his/her obligations under this condition. Applicant shall reimburse the County for any court costs and attorney's fees that the County may be required to pay as a result of such action. The County shall promptly notify the applicant of any such claim, action or proceeding.

6 LOT 4 TT19108 (Custom)

As described in Note 35 of VTTM19108, Lot 4 shall be developed exclusively as a pocket park/open space and shall not be developed as a residential lot. This language shall be included and recorded as part of any final map encompassing Lot 4 of VTTM19108.

7

PROPOSED FUTURE POCKET PARK

TT19108 (Custom)

Prior to issuance of any grading or building permits for Lot 4, the subdivider shall submit a Site Development Permit application for all proposed recreation uses and facilities on Lot 4 as required by The Ranch Plan PC Text Section III.A.1.a.3)a), and in accordance with The Ranch Plan PC Text Section II.C.

APPENDIX C

Item No.	Cross Reference Column	Source	Condition, Mitigation, Public Benefit or Entitlement Provision	Timing	Subject	Keywords	Title	Requirements or Entitlement Provisions	Reviewing / Approving Authority (Advisory Agency in Parentheses)	Form of Compliance	Guidance for Compliance	Area Application	Applicant Comments	County Comments	Satisfied or Not Satisfied Y/N
a. Prior to Recordation															
139	137-138 (EIR 589, MM 4.9-27)	EIR 589	MM 4.9-27 (cont.)	Prior to the recordation of a map for tract adjacent to the RMV Open Space	Biological Resources	CC&Rs, California Exotic Pest Plant Council	Invasive Plants CC&R Prohibition	b. Prior to the recordation of a map for a tract adjacent to the RMV Open Space, the County of Orange shall verify that the CC&Rs contain language prohibiting the planting of plants identified by the California Exotic Pest Plant Council as an invasive risk in Southern California in private landscaped areas.	Director, PDS Director, OC Planning	Provide letter stating that CC&Rs contain language prohibiting the planting of plants on most current California Invasive Plant Inventory	To be cleared for entire Planned Community, upon providing RMV CC&R summary letter [Hyperlink #13] stating CC&Rs contain language prohibiting the planting of plants on most current California Invasive Plant Inventory (www.cal-ipc.org) in private landscape areas. Only applies to recordation of tract maps that include lots located immediately adjacent to RMV Open Space	Each PA			
524		EIR 589	SC 4.4-3	Prior to the recordation of a subdivision map or prior to issuance of a Grading Permit, whichever comes first	Geology and Soils (cont.):		Geology and Soils (cont.):	Prior to the recordation of a subdivision map or prior to the issuance of any grading permit, whichever comes first, and if determined necessary by the County of Orange Manager, Subdivision and Grading, the applicant shall record a letter of consent from the affected property owners permitting off-site grading, cross lot drainage, drainage diversions and/or unnatural concentrations. The applicant shall obtain approval of the form of the letter of consent from the Manager, Subdivision and Grading Services before recordation of the letter. (County Standard Condition G04)	County of Orange Director of Planning & Development Services, Director, OC Planning	Recordation of a letter of consent from affected property owners if determined necessary by County of Orange Director of Planning & Development Services		Each PA			
527		EIR 589	SC 4.5-1	Prior to recordation of a Subdivision Map or issuance of a Grading Permit, whichever comes first	Drainage Study:		Drainage Study:	Prior to the recordation of a subdivision map (except maps for financing and conveyance purposes only) or prior to the issuance of any grading permits, whichever comes first, the following drainage studies shall be submitted to and approved by the Manager, Subdivision and Grading: (County Standard Condition D01a)	County of Orange Director of Planning & Development Services, Director, OC Planning	Submittal of satisfactory of drainage study		Each PA			

Item No.	Cross Reference Column	Source	Condition, Mitigation, Public Benefit or Entitlement Provision	Timing	Subject	Keywords	Title	Requirements or Entitlement Provisions	Reviewing / Approving Authority (Advisory Agency in Parentheses)	Form of Compliance	Guidance for Compliance	Area Application	Applicant Comments	County Comments	Satisfied or Not Satisfied Y/N
527.1		EIR 589	SC 4.5-1 (cont.)	See above	Drainage Study (cont.):		Drainage Study (cont.):	A. A drainage study of the project including diversions, off-site areas that drain onto and/or through the project, and justification of any diversions; and B. When applicable, a drainage study evidencing that proposed drainage patterns will not overload existing storm drains; and C. Detailed drainage studies indicating how the project grading, in conjunction with the drainage conveyance systems including applicable swales, channels, street flows, catch basins, storm drains, and flood water retarding, will allow building pads to be safe from inundation from rainfall runoff which may be expected from all storms up to and including the theoretical 100-year flood. (County Standard Condition D01a)	See above	See above		Each PA			
528		EIR 589	SC 4.5-2	Prior to recordation of a Subdivision Map or Issuance of a Grading Permit, whichever comes first	Drainage Improvements:		Drainage Improvements:	A. Prior to the recordation of a subdivision map (except maps for financing and conveyance purposes only) or prior to the issuance of any grading permits, whichever comes first, the applicant shall in a manner meeting the approval of the Manager, Subdivision and Grading: (County Standard Condition D02a)	County of Orange Director of Planning & Development Services, Director, OC Planning	Approval of storm drain drainage plans and offer(s) of dedication, if necessary		Each PA			
528.1		EIR 589	SC 4.5-2 (cont.)	See above	Drainage Improvements (cont.):		Drainage Improvements (cont.):	1) Design provisions for surface drainage; 2) Design all necessary storm drain facilities extending to a satisfactory point of disposal for the proper control and disposal of storm runoff; and 3) Dedicate the associated easements to the County of Orange, if determined necessary. (County Standard Condition D02a)	See above	See above		Each PA			
529		EIR 589	SC 4.5-2 (cont.)	Prior to recordation of a Subdivision Map or Issuance of a Certificate of Use and Occupancy, whichever comes first	Drainage Improvements (cont.):		Drainage Improvements (cont.):	B. Prior to the recordation of a subdivision map (except maps for financing and conveyance purposes only) or prior to the issuance of any certificates of use and occupancy, whichever occurs first, said improvements shall be constructed in a manner meeting the approval of the Manager, Construction. (County Standard Condition D02a)	County of Orange Manager of Inspection, Manager, OC Inspection Division	Verification of construction of drainage improvement		Each PA			

Item No.	Cross Reference Column	Source	Condition, Mitigation, Public Benefit or Entitlement Provision	Timing	Subject	Keywords	Title	Requirements or Entitlement Provisions	Reviewing / Approving Authority (Advisory Agency in Parentheses)	Form of Compliance	Guidance for Compliance	Area Application	Applicant Comments	County Comments	Satisfied or Not Satisfied Y/N
532		EIR 589	SC 4.5-4	Prior to the recordation of a Subdivision Map (except maps for financing and conveyance purposes only)	Master Plan of Drainage:		Master Plan of Drainage:	Prior to the recordation of a subdivision map (except maps for financing and conveyance purposes only), the subdivider shall participate in the applicable Master Plan of Drainage in a manner meeting the approval of the Manager, Subdivision and Grading, including payment of fees and the construction (or provide evidence of financial security, such as bonding) of the necessary facilities. (County Standard Condition D04b)	County of Orange Director of Planning & Development Services – Director, OC Planning	Verification of participation in Master Plan of Drainage (fees and/or improvements)	See guidance above related to Item No. 30.	Each PA			
533		EIR 589	SC 4.5-5	Prior to the recordation of a Subdivision Map	Subordination of Easements:		Subordination of Easements:	Prior to the recordation of a subdivision map (except maps for financing and conveyance purposes only), the subdivider shall not grant any easements over any property subject to a requirement of dedication or irrevocable offer to the County of Orange or the Orange County Flood Control District, unless such easements are expressly made subordinate to the easements to be offered for dedication to the County. Prior to granting any of said easements, the subdivider shall furnish a copy of the proposed easement to the Manager, Subdivision and Grading, for review and approval. (County Standard Condition D06b)	County of Orange Director of Planning & Development Services – Director, OC Planning (Orange County Flood Control District and Santa Margarita Water District)	Verification that any granted easements are subordinate to easements offered to County and provision of copy of said easement(s)	Except in those cases where the County of Orange and the public entity grantee have previously mutually agreed upon conditions to coexist within the easement area.	Each PA			
534		EIR 589	SC 4.5-5 (cont.)	See above	Subordination of Easements (cont.):		Subordination of Easements (cont.):	The Santa Margarita Water District would restore other improvements or facilities located within the easement, if it has consented to the location of such improvements or facilities to the extent that the exercise of its rights in connecting with the easement impacts other improvements of facilities located within the easement; however, in no event shall Santa Margarita Water District be responsible for the cost of relocating its facilities in event of conflicts with such improvements or facilities. (County Standard Condition D06b)	County of Orange Director of Planning & Development Services – Director, OC Planning (Orange County Flood Control District and Santa Margarita Water District)	See above	Except in those cases where the County of Orange and the public entity grantee have previously mutually agreed upon conditions to coexist within the easement area.	Each PA			

Item No.	Cross Reference Column	Source	Condition, Mitigation, Public Benefit or Entitlement Provision	Timing	Subject	Keywords	Title	Requirements or Entitlement Provisions	Reviewing / Approving Authority (Advisory Agency in Parentheses)	Form of Compliance	Guidance for Compliance	Area Application	Applicant Comments	County Comments	Satisfied or Not Satisfied Y/N
535		EIR 589	SC 4.5-6	Prior to County of Orange acceptance of improvements as identified by separate agreement the recordation of a Subdivision Map	Regional Facility Improvements:		Regional Facility Improvements:	Prior to County of Orange acceptance of improvements as identified by separate agreement the recordation of a subdivision map, the applicant shall improve Regional Facility _____ by the construction (or evidence of financial security, such as bonding) of _____, an IOD shall be recorded offering said improvements and dedicate right-of-way to the Orange County Flood Control District in a manner meeting the approval of the Manager, Subdivision and Grading. County of Orange to accept IOD upon satisfactory completion of improvements. (County Standard Condition D07b, modified)	County of Orange Director of Planning & Development Services, Director, OC Planning (Orange County Flood Control District and Santa Margarita Water District)	Verification of construction and/or offer(s) of dedication for flood control improvements		Each PA			
537		EIR 589	SC 4.5-8	Prior to the recordation of a Subdivision Map or the issuance of any Grading or Building Permit, whichever comes first	Water Quality Management Plan:		Water Quality Management Plan:	Prior to the recordation of any final subdivision map (except those maps for financing or conveyance purposes only) or the issuance of any grading or building permit (whichever comes first), the applicant shall submit for review and approval by the Manager, Inspection Services Division, a Water Quality Management Plan (WQMP) specifically identifying Best Management Practices (BMPs) that will be used onsite to control predictable pollutant runoff. This WQMP shall identify, at a minimum, the routine structural and non-structural measures specified in the current Drainage Area Management Plan (DAMP). The WQMP may include one or more of the following: (County Standard Condition WQ01)	County of Orange Director of Planning & Development Services, Director, OC Planning	Submittal of satisfactory Water Quality Management Plan		Each PA			
537.1		EIR 589	SC 4.5-8 (cont.)	See above	Water Quality Management Plan (cont.):		Water Quality Management Plan (cont.):	<ul style="list-style-type: none"> • Discuss regional water quality and/or watershed programs (if available for the project); • Address Site Design BMPs (as applicable) such as minimizing impervious areas, maximizing permeability, minimizing directly connected impervious areas, creating reduced or "zero discharge" areas, and conserving natural areas; • Include the applicable Routine Source Control BMPs as defined in the DAMP. (County Standard Condition WQ01) 	See above	See above		Each PA			

Item No.	Cross Reference Column	Source	Condition, Mitigation, Public Benefit or Entitlement Provision	Timing	Subject	Keywords	Title	Requirements or Entitlement Provisions	Reviewing / Approving Authority (Advisory Agency in Parentheses)	Form of Compliance	Guidance for Compliance	Area Application	Applicant Comments	County Comments	Satisfied or Not Satisfied Y/N
538		EIR 589	SC 4.5-8 (cont.)	See above	Water Quality Management Plan (cont.):		Water Quality Management Plan (cont.):	Demonstrate how surface runoff and subsurface drainage shall be managed and directed to the nearest acceptable drainage facility (as applicable), via sump pumps if necessary. (Standard Condition of Approval, WQ03)	See above	See above		Each PA			
544		EIR 589	SC 4.6-2	Prior to the recordation of a Subdivision Map	Vehicular Access Rights:		Vehicular Access Rights:	Prior to the recordation of a subdivision map, the subdivider shall place notes on the final map which release and relinquish vehicular access rights to all arterial highways to the County of Orange, except for access locations approved by the County of Orange, in a manner meeting the approval of the Manager, Subdivision and Grading. (County Standard Condition T01)	County of Orange Director of Planning & Development Services, Director, OC Planning	Verification of notes on the final map which release and relinquish vehicular access rights to all arterial highways to the County of Orange except for access locations approved by the County of Orange	Note shall state: "Rancho Mission Viejo or assigns hereby release and relinquish vehicular access rights to all arterial highways to the County of Orange, except for access locations approved by the County of Orange"	Each PA			
545		EIR 589	SC 4.6-3	Prior to the recordation of a Subdivision Map	Private Street Improvements:		Private Street Improvements:	Prior to the recordation of a subdivision map, the subdivider shall place a note on the map, in a manner that meets the approval of the Manager, Subdivision and Grading Services, that states: "The private streets constructed within this map shall be owned, operated and maintained by the developer, successors or assigns. The County of Orange shall have no responsibility therefore unless pursuant to appropriate sections of the Streets and Highways Code of the State of California, the said private streets have been accepted into the County Road System by appropriate resolution of the Orange County Board of Supervisors. (County Standard Condition T02)	County of Orange Director of Planning & Development Services, Director, OC Planning	Verification of a note on the Subdivision Map	Note shall make statement listed in quotations in condition.	Each PA			
546		EIR 589	SC 4.6-4	Prior to the recordation of a Subdivision Map	Street Improvements (cont.):		Street Improvements (cont.):	Prior to the recordation of a subdivision map, the subdivider shall design and construct (or provide evidence of financial security, such as bonding) the following improvements in accordance with plans and specifications meeting the approval of the Manager, Subdivision and Grading: (County Standard Condition T04)	County of Orange Director of Planning & Development Services, Director, OC Planning	Submittal of satisfactory improvements and utility plans with verification of subsequent construction/in stallation of improvements	If applicable, bonding may substitute for construction of each of the required improvements.	Each PA			
546.1		EIR 589	SC 4.6-4 (cont.)	See above	Street Improvements (cont.):		Street Improvements (cont.):	A. Streets, bus stops, on-road bicycle trails, street names, signs, striping and stenciling. (County Standard Condition T04)	See above	See above	See above	Each PA			

Item No.	Cross Reference Column	Source	Condition, Mitigation, Public Benefit or Entitlement Provision	Timing	Subject	Keywords	Title	Requirements or Entitlement Provisions	Reviewing / Approving Authority (Advisory Agency in Parentheses)	Form of Compliance	Guidance for Compliance	Area Application	Applicant Comments	County Comments	Satisfied or Not Satisfied Y/N
546.2		EIR 589	SC 4.6-4 (cont.)	See above	Street Improvements (cont.):		Street Improvements (cont.):	B. The water distribution system and appurtenances shall also conform to the applicable laws and adopted regulations enforced by the County Fire Chief. (County Standard Condition T04)	See above	See above	See above	Each PA			
546.3		EIR 589	SC 4.6-4 (cont.)	See above	Street Improvements (cont.):		Street Improvements (cont.):	C. Underground utilities (including gas, cable, electrical and telephone), streetlights, and mailboxes. (County Standard Condition T04)	See above	See above	See above	Each PA			
549		EIR 589	SC 4.6-7	Prior to the recordation of a Subdivision Map	Traffic Signal Conduit:		Traffic Signal Conduit:	Prior to the recordation of a subdivision map, the subdivider shall install (or provide evidence of financial security, such as bonding, that) all underground traffic signal conduits (e.g., signals, phones, power, loop detectors, etc.) and other appurtenances (e.g., pull boxes, etc.) needed for future traffic signal construction, and for future interconnection with adjacent intersections, all in accordance with plans and specifications meeting the approval of the Manager, Subdivision and Grading. (County Standard Condition T08)	County of Orange Director of Planning & Development Services, Director, OC Planning	Approved traffic signal plans with verification of subsequent installation	If applicable, bonding may substitute for construction of each of the required improvements.	Each PA			
550		EIR 589	SC 4.6-8	Prior to the recordation of a Subdivision Map or prior to the issuance of Building Permits, whichever occurs first	Internal Circulation:		Internal Circulation:	A. Prior to the recordation of a subdivision map, the subdivider shall install (or provide evidence of financial security, such as bonding, that) all underground traffic signal conduits (e.g., signals, phones, power, loop detectors, etc.) and other appurtenances (e.g., pull boxes, etc.) needed for future traffic signal construction, and for future interconnection with adjacent intersections, all in accordance with plans and specifications meeting the approval of the Manager, Subdivision and Grading, for the design of the following improvements: (County Standard Condition T12)	County of Orange Director of Planning & Development Services,	Submittal of satisfactory street improvement plans		Each PA			
550.1		EIR 589	SC 4.6-8 (cont.)	See above	Internal Circulation (cont.):		Internal Circulation (cont.):	1) Internal street common private drive system. (County Standard Condition T12)	See above	See above		Each PA			
550.2		EIR 589	SC 4.6-8 (cont.)	See above	Internal Circulation (cont.):		Internal Circulation (cont.):	2) Entrance to the site to emphasize that the development is private by use of signs and other features. (Standard Condition of Approval T12)	See above	See above		Each PA			
550.3		EIR 589	SC 4.6-8 (cont.)	Prior to the recordation of Subdivision Map.	Internal Circulation (cont.):		Internal Circulation (cont.):	B. Prior to the recordation of a subdivision map, the applicant shall construct (or provide evidence of financial security, such as bonding) the above improvements in a manner meeting the approval of the Manager, Construction. (County Standard Condition T12)	County of Orange Manager of Inspection, Manager, OC Inspection Division	Verification of improvements' construction in SC 4.6-8A	If applicable, bonding may substitute for construction of each of the required improvements.	Each PA			
551		EIR 589	SC 4.6-9	Prior to the recordation of a Subdivision Map	Traffic Signal Maintenance Easement:		Traffic Signal Maintenance Easement:	Prior to the recordation of a subdivision map, the subdivider shall dedicate a signal maintenance easement to the County of Orange at the project site access, in a manner meeting the approval of the Manager, Subdivision and Grading. (County Standard Condition T13b)	County of Orange Director of Planning & Development Services, Director, OC Planning	Submittal of offer(s) of dedication for signal maintenance easement(s)		Each PA			

Item No.	Cross Reference Column	Source	Condition, Mitigation, Public Benefit or Entitlement Provision	Timing	Subject	Keywords	Title	Requirements or Entitlement Provisions	Reviewing / Approving Authority (Advisory Agency in Parentheses)	Form of Compliance	Guidance for Compliance	Area Application	Applicant Comments	County Comments	Satisfied or Not Satisfied Y/N
552		EIR 589	SC 4.6-10	Prior to the recordation of a Subdivision Map	Traffic Signal Installation:		Traffic Signal Installation:	Prior to the recordation of a subdivision map, the subdivider shall design and construct/provide a cash deposit of ___ % of the cost of / /enter into an agreement with the County of Orange, accompanied by financial security, for the cost of ___ % of) a traffic signal at the intersection of ___ and ___, in a manner meeting the approval of the Manager, Subdivision and Grading. (County Standard Condition T14b)	County-of-Orange-Director-of-Planning-&-Development-Services, Director, OC Planning	Verification of approved street improvement plans with subsequent installation of improvements or enter into agreement with County for construction (with appropriate financial security)	If applicable, bonding may substitute for construction of each of the required improvements.	Each PA			
559		EIR 589	SC 4.8-3	See below	Sound Attenuation:		Sound Attenuation:	The applicant shall sound attenuate all residential lots and dwellings against present and projected noise (which shall be the sum of all noise impacting the project) so that the composite interior standard of 45 dBA CNEL for habitable rooms and a source specific exterior standard of 65 dBA CNEL for outdoor living areas is not exceeded. The applicant shall provide a report prepared by a County-certified acoustical consultant, which demonstrates that these standards will be satisfied in a manner consistent with Zoning Code Section 7-9-137.5, as follows: (County Standard Condition N01)	County-of-Orange-Director-of-Planning-&-Development-Services-and-County-of-Orange-Manager-of-Building-Permits-Services, Director, OC Planning and Manager, Permit Services (Building Plan Check)	Submittal of satisfactory acoustical analysis	Staff may determine that no attenuation is necessary, and no action is required (as occurred in PA1). In such a case a "not applicable" memo is to be prepared. Applicant and County staff to address AC units in side yards as soon as possible.	Each PA			
559.1		EIR 589	SC 4.8-3 (cont.)	Prior to the recordation of a subdivision map or prior to the issuance of grading permits	Sound Attenuation (cont.):		Sound Attenuation (cont.):	a. Prior to the recordation of a subdivision map or prior to the issuance of grading permits, as determined by the Manager, Building Permits Services, the applicant shall submit an acoustical analysis report to the Manager, Building Permits Services, for approval. The report shall describe in detail the exterior noise environment and preliminary mitigation measures. Acoustical design features to achieve interior noise standards may be included in the report in which case it may also satisfy Condition B below. (County Standard Condition N01)	See above	See above		Each PA			

Item No.	Cross Reference Column	Source	Condition, Mitigation, Public Benefit or Entitlement Provision	Timing	Subject	Keywords	Title	Requirements or Entitlement Provisions	Reviewing / Approving Authority (Advisory Agency in Parentheses)	Form of Compliance	Guidance for Compliance	Area Application	Applicant Comments	County Comments	Satisfied or Not Satisfied Y/N
589.1		EIR 589	SC 4.15-1	Prior to recordation of final tract a-subdivision maps (alternatively subdivider may enter into a subdivision improvement agreement with the County	Water Improvement Plans:		Water Improvement Plans:	Prior to the recordation of a subdivision map, the subdivider shall design and construct (or provide evidence of financial security, such as bonding) water distribution system and appurtenances that conform to the applicable laws and adopted regulations enforced by the County Fire Chief, in accordance with plans and specifications meeting the approval of the Manager, Subdivision and Grading. (Added per MMRP attached to 11/8/06 CEQA Resolution 04-290)	County of Orange Director of Planning & Development Services Director, OC Planning (OCFA)	Approved water improvement plans with subsequent construction of improvement	Applicant must submit one of the following: (1) approved improvement plan consisted with referenced Plan of Works, (2) letters from both SMWD and OCFA indicating sufficient water supply and pressure for Map area, or (3) subdivision improvement agreement with County.	Each PA			
597		EIR 589	SC 4.15-9		CUSD Fees:		CUSD Fees:	Prior to the recordation of final tract map, the project applicant shall provide for the payment of fees pursuant to California Government Code Section 65995, unless other provision are required of the applicant through the agreement with CUSD (see Mitigation Measure 4.15-5).	N/A	Compliance with CUSD agreement	Payment of school fees per CUSD/RMV Agreement	PC-Wide			
619		Fire Prot. Prog.	Cond. 4	Prior to recordation of each Tract Map	Administrative Approval of Tract Maps		Administrative Approval of Tract Maps	Prior to recordation of each Tract Map, the applicant shall submit a copy of the proposed Tract map to OCFA for administrative approval (verifying that the map remains consistent with previous approvals), and for OCFA's record keeping purposes.	Director, PDS, Director, OC Planning	Submit a copy of the proposed Tract map to OCFA for administrative approval					
COA #7		PA2.3 Builder "B" Map COAs	Cond. #7	Prior to recordation of the final tract map			MANEUVERABILITY EASEMENT	Prior to recordation of the final tract map, the subdivider shall demonstrate that all necessary ingress/egress easements for vehicle maneuverability within motor courts/alleyways are identified on the final map subject to the satisfaction of the Planning Manager. The easement shall prohibit property owners from installing any improvements within the easement area or interfering with the use or maintenance of the easement.	Director, PDS, Director, OC Planning	Submit a copy of the proposed Tract map to OCFA for administrative approval					

Item No.	Cross Reference Column	Source	Condition, Mitigation, Public Benefit or Entitlement Provision	Timing	Subject	Keywords	Title	Requirements or Entitlement Provisions	Reviewing / Approving Authority (Advisory Agency in Parentheses)	Form of Compliance	Guidance for Compliance	Area Application	Applicant Comments	County Comments	Satisfied or Not Satisfied Y/N
b. Prior to Approval of Site Development Permit															
109		EIR 589	MM 4.7-3	Prior to approval of Master Area Plan or Subarea Plan Site Development Permit	Air Quality	Shade trees, evaporative emissions	Incorporate Shade Trees into Parking Lot Design	With the submittal of each Master Area Plan, the project applicant shall identify how shade trees can be incorporated into parking lot designs (to reduce evaporative emissions from parked vehicles); where shade trees can be sited (to reduce summer cooling needs); and how shade trees would be incorporated into bicycle and pedestrian path design. <i>[Note: for the purposes of clarification, the timing of this requirement should be interpreted to read as follows: Prior to approval of each applicable Site Development permit, the project applicant shall ...]</i>	Director, PDS Director, OC Planning	Submittal of satisfactory landscape plans (precise, not general landscape plan at SDP level)		Each PA			
110	111 (MM 4.7-3)	EIR 589	MM 4.7-3 (cont.)	Prior to approval of Master Area Plan or Subarea Plan Site Development Permit	Air Quality	Light-colored roof materials	Use Light-Colored Roof Materials to Reflect Heat (Item Nos. 110-111)	As a part of each Master Area Plan, the applicant shall identify how the use of light-colored roof materials and paint to reflect heat to the extent feasible has been incorporated into the design plans. <i>[Note: for the purposes of clarification, the timing of this requirement should be interpreted to read as follows: Prior to approval of each applicable Site Development permit, the project applicant shall ...]</i>	Director, PDS Director, OC Planning	Issuance of Building Permit (Evidence of reflection of materials)		Each PA			

Item No.	Cross Reference Column	Source	Condition, Mitigation, Public Benefit or Entitlement Provision	Timing	Subject	Keywords	Title	Requirements or Entitlement Provisions	Reviewing / Approving Authority (Advisory Agency in Parentheses)	Form of Compliance	Guidance for Compliance	Area Application	Applicant Comments	County Comments	Satisfied or Not Satisfied Y/N
c. Prior to Issuance of Grading Permits															
521		EIR 589	SC 4.4-1	Prior to the issuance of a grading permit	Geology and Soils:		Geology and Soils:	Prior to the issuance of a grading permit, the applicant shall submit a geotechnical report to the Manager of Subdivision Manager OC Planned Communities and Grading, for approval. The report shall meet the requirements outlined in the County of Orange Grading Code and Manual. (County Standard Condition G01)	County of Orange Director of Planning & Development Services, Director, OC Planning	Submittal of satisfactory geotechnical report		Each PA			
522		EIR 589	SC 4.4-2	Prior to the issuance of a grading permit	Geology and Soils (cont.):		Geology and Soils (cont.):	Prior to the issuance of any grading permits, the Manager of Subdivision and Grading shall review the grading plan for conformance with the grading shown on the approved tentative map. If the applicant submits a grading plan which the Manager of Subdivision and Grading Manager OC Planned Communities determines to show a significant deviation from the grading shown on the approved tentative map, specifically with regard to slope heights, slope ratios, pad elevations or configurations, the Subdivision Committee shall review the plan for a finding of substantial conformance. (County Standard Condition G02)	County of Orange Director of Planning & Development Services, Director, OC Planning	Approval of grading plan demonstrating submittal conformance with the grading shown on the approved TTM		Each PA			
523		EIR 589	SC 4.4-2 (cont.)	Prior to the issuance of a grading permit	Geology and Soils (cont.):		Geology and Soils (cont.):	If the Subdivision Committee fails to make such a finding, the applicant shall process a revised tentative map; or, if a final map has been recorded, the applicant shall process a new tentative map or a site development permit application per Orange County Zoning Code Sections 7-9-139 and 7-9-150. Additionally, the applicant shall process a new environmental assessment for determination by the decision making entity. (County Standard Condition G02)	Subdivision Committee review for substantial conformance, if required	Process new subdivision, if necessary		Each PA			
524		EIR 589	SC 4.4-3	Prior to the recordation of a subdivision map or prior to issuance of a Grading Permit, whichever comes first	Geology and Soils (cont.):		Geology and Soils (cont.):	Prior to the recordation of a subdivision map or prior to the issuance of any grading permit, whichever comes first, and if determined necessary by the County of Orange Manager, Subdivision and Grading, the applicant shall record a letter of consent from the affected property owners permitting off-site grading, cross lot drainage, drainage diversions and/or unnatural concentrations. The applicant shall obtain approval of the form of the letter of consent from the Manager, Subdivision and Grading Services before recordation of the letter. (County Standard Condition G04)	County of Orange Director of Planning & Development Services, Director, OC Planning	Recordation of a letter of consent from affected property owners if determined necessary by County of Orange Director of Planning & Development Services		Each PA			

Item No.	Cross Reference Column	Source	Condition, Mitigation, Public Benefit or Entitlement Provision	Timing	Subject	Keywords	Title	Requirements or Entitlement Provisions	Reviewing / Approving Authority (Advisory Agency in Parentheses)	Form of Compliance	Guidance for Compliance	Area Application	Applicant Comments	County Comments	Satisfied or Not Satisfied Y/N
525		EIR 589	SC 4.4-4	Prior to the issuance of grading permits	Geology and Soils (cont.):		Geology and Soils (cont.):	Prior to issuance of grading permits, the Manager of Subdivision and Grading Manager OC Planned Communities shall determine that the proposed grading is consistent with the grading depicted within the approved planning application. (County Standard Condition G09)	County of Orange Director of Planning & Development Services, Director, OC Planning	Approval of grading plan		Each PA			
527		EIR 589	SC 4.5-1	Prior to recordation of a Subdivision Map or issuance of a Grading Permit, whichever comes first	Drainage Study:		Drainage Study:	Prior to the recordation of a subdivision map (except maps for financing and conveyance purposes only) or prior to the issuance of any grading permits, whichever comes first, the following drainage studies shall be submitted to and approved by the Manager, Subdivision and Grading: (County Standard Condition D01a)	County of Orange Director of Planning & Development Services, Director, OC Planning	Submittal of satisfactory of drainage study		Each PA			
527.1		EIR 589	SC 4.5-1 (cont.)	See above	Drainage Study (cont.):		Drainage Study (cont.):	A. A drainage study of the project including diversions, off-site areas that drain onto and/or through the project, and justification of any diversions; and B. When applicable, a drainage study evidencing that proposed drainage patterns will not overload existing storm drains; and C. Detailed drainage studies indicating how the project grading, in conjunction with the drainage conveyance systems including applicable swales, channels, street flows, catch basins, storm drains, and flood water retarding, will allow building pads to be safe from inundation from rainfall runoff which may be expected from all storms up to and including the theoretical 100-year flood. (County Standard Condition D01a)	See above	See above		Each PA			
528		EIR 589	SC 4.5-2	Prior to recordation of a Subdivision Map or Issuance of a Grading Permit, whichever comes first	Drainage Improvements:		Drainage Improvements:	A. Prior to the recordation of a subdivision map (except maps for financing and conveyance purposes only) or prior to the issuance of any grading permits, whichever comes first, the applicant shall in a manner meeting the approval of the Manager, Subdivision and Grading: (County Standard Condition D02a)	County of Orange Director of Planning & Development Services, Director, OC Planning	Approval of storm drain drainage plans and offer(s) of dedication, if necessary		Each PA			
528.1		EIR 589	SC 4.5-2 (cont.)	See above	Drainage Improvements (cont.):		Drainage Improvements (cont.):	1) Design provisions for surface drainage; 2) Design all necessary storm drain facilities extending to a satisfactory point of disposal for the proper control and disposal of storm runoff; and 3) Dedicate the associated easements to the County of Orange, if determined necessary. (County Standard Condition D02a)	See above	See above		Each PA			

Item No.	Cross Reference Column	Source	Condition, Mitigation, Public Benefit or Entitlement Provision	Timing	Subject	Keywords	Title	Requirements or Entitlement Provisions	Reviewing / Approving Authority (Advisory Agency in Parentheses)	Form of Compliance	Guidance for Compliance	Area Application	Applicant Comments	County Comments	Satisfied or Not Satisfied Y/N
530		EIR 589	SC 4.5-3	Prior to the issuance of Grading Permits	Drainage Improvements (cont.):		Drainage Improvements (cont.):	A. Prior to the issuance of any grading permits, the applicant shall in a manner meeting the approval of the Manager, Subdivision and Grading: (County Standard Condition D02b)	County of Orange Director of Planning & Development Services, Director, OC Planning	Submittal of satisfactory drainage plans		Each PA			
530.1		EIR 589	SC 4.5-3 (cont.)	See above	Drainage Improvements (cont.):		Drainage Improvements (cont.):	1) Design provisions for surface drainage; and 2) Design all necessary storm drain facilities extending to a satisfactory point of disposal for the proper control and disposal of storm runoff; and 3) Dedicate the associated easements to the County of Orange, if determined necessary. (County Standard Condition D02b)	See above	See above		Each PA			
537		EIR 589	SC 4.5-8	Prior to the recordation of a Subdivision Map or the issuance of any Grading or Building Permit, whichever comes first	Water Quality Management Plan:		Water Quality Management Plan:	Prior to the recordation of any final subdivision map (except those maps for financing or conveyance purposes only) or the issuance of any grading or building permit (whichever comes first), the applicant shall submit for review and approval by the Manager, Inspection Services Division, a Water Quality Management Plan (WQMP) specifically identifying Best Management Practices (BMPs) that will be used onsite to control predictable pollutant runoff. This WQMP shall identify, at a minimum, the routine structural and non-structural measures specified in the current Drainage Area Management Plan (DAMP). The WQMP may include one or more of the following: (County Standard Condition WQ01)	County of Orange Director of Planning & Development Services, Director, OC Planning	Submittal of satisfactory Water Quality Management Plan		Each PA			

Item No.	Cross Reference Column	Source	Condition, Mitigation, Public Benefit or Entitlement Provision	Timing	Subject	Keywords	Title	Requirements or Entitlement Provisions	Reviewing / Approving Authority (Advisory Agency in Parentheses)	Form of Compliance	Guidance for Compliance	Area Application	Applicant Comments	County Comments	Satisfied or Not Satisfied Y/N
537.1		EIR 589	SC 4.5-8 (cont.)	See above	Water Quality Management Plan (cont.):		Water Quality Management Plan (cont.):	<ul style="list-style-type: none"> • Discuss regional water quality and/or watershed programs (if available for the project); • Address Site Design BMPs (as applicable) such as minimizing impervious areas, maximizing permeability, minimizing directly connected impervious areas, creating reduced or "zero discharge" areas, and conserving natural areas; • Include the applicable Routine Source Control BMPs as defined in the DAMP. (County Standard Condition WQ01) 	See above	See above		Each PA			
538		EIR 589	SC 4.5-8 (cont.)	See above	Water Quality Management Plan (cont.):		Water Quality Management Plan (cont.):	Demonstrate how surface runoff and subsurface drainage shall be managed and directed to the nearest acceptable drainage facility (as applicable), via sump pumps if necessary. (Standard Condition of Approval, WQ03)	See above	See above		Each PA			
540		EIR 589	SC 4.5-10	Prior to the issuance of any Grading or Building Permits	Stormwater Pollution Prevention Plan.		Stormwater Pollution Prevention Plan.	<p>Prior to the issuance of any grading or building permits, the applicant shall demonstrate compliance under California's General Permit for Stormwater Discharges Associated with Construction Activity by providing a copy of the Notice of Intent (NOI) submitted to the State Water Resources Control Board and a copy of the subsequent notification of the issuance of a Waste Discharge Identification (WDID) Number or other proof of filing in a manner meeting the satisfaction of the Manager, Building Permit Services. Projects subject to this requirement shall prepare and implement a Stormwater Pollution Prevention Plan (SWPPP). A copy of the current SWPPP shall be kept at the project site and be available for County review on request. (County Standard Condition WQ04)</p>	County of Orange Manager of Building Inspection - Manager, OC Inspection Division (Regional Water Quality Control Board)	Provision of Notice of Intent and verification of a copy of the Storm Water Pollution Prevention Plan (SWPPP); at the project site		Each PA			

Item No.	Cross Reference Column	Source	Condition, Mitigation, Public Benefit or Entitlement Provision	Timing	Subject	Keywords	Title	Requirements or Entitlement Provisions	Reviewing / Approving Authority (Advisory Agency in Parentheses)	Form of Compliance	Guidance for Compliance	Area Application	Applicant Comments	County Comments	Satisfied or Not Satisfied Y/N
541		EIR 589	SC 4.5-11	Prior to the issuance of any Grading or Building Permits	Erosion and Sediment Control Plan.		Erosion and Sediment Control Plan.	Prior to the issuance of any grading or building permit, the applicant shall submit a Erosion and Sediment Control Plan (ESCP) in a manner meeting approval of the Manager, Building Permit Services, to demonstrate compliance with local and state water quality regulations for grading and construction activities. The ESCP shall identify how all construction materials, wastes, grading or demolition debris, and stockpiles of soil, aggregates, soil amendments, etc. shall be properly covered, stored, and secured to prevent transport into local drainages or coastal waters by wind, rain, tracking, tidal erosion or dispersion. The ESCP shall also describe how the applicant will ensure that all BMPs will be maintained during construction of any future public right-of-ways. A copy of the current ESCP shall be kept at the project site and be available for County review on request. (County Standard Condition WQ05)	County of Orange Manager of Building Permits, Manager, Permit Services (Building Plan Check)	Submittal of satisfactory Erosion and Sediment Control Plan (ESCP); verification of copy of ESCP at project site		Each PA			
548		EIR 589	SC 4.6-6	Prior to the issuance of Grading Permits	Sight Distance:		Sight Distance:	Prior to the issuance of any grading permits, the applicant shall provide adequate sight distance per Standard Plan 1117 at all street intersections, in a manner meeting the approval of the Manager, Subdivision and Grading. The applicant shall make all necessary revisions to the plan to meet the sight distance requirement such as removing slopes or other encroachments from the limited use area in a manner meeting the approval of the Manager, Subdivision and Grading Services. (Standard Condition of Approval T07)	County of Orange Director of Planning & Development Services, Director, OC Planning	Approved grading plans verifying adequate sight distance		Each PA			
555		EIR 589	SC 4.7-1	Prior to the issuance of a grading permit	Fugitive Dust:		Fugitive Dust:	All construction contractors shall comply with South Coast Air Quality Management District (SCAQMD) regulations, including Rule 403, Fugitive Dust, and Rule 402, Nuisance. All grading (regardless of acreage) shall apply best available control measures for fugitive dust in accordance with Rule 403. To ensure that the project is in full compliance with applicable SCAQMD dust regulations and that there is no nuisance impact off the site, the contractor would implement each of the following:	County of Orange Director of Planning & Development Services, Director, OC Planning	Verification of compliance with Rule 403 and Rule 402		Each PA			

Item No.	Cross Reference Column	Source	Condition, Mitigation, Public Benefit or Entitlement Provision	Timing	Subject	Keywords	Title	Requirements or Entitlement Provisions	Reviewing / Approving Authority (Advisory Agency in Parentheses)	Form of Compliance	Guidance for Compliance	Area Application	Applicant Comments	County Comments	Satisfied or Not Satisfied Y/N
555.1		EIR 589	SC 4.7-1 (cont.)	See above	Fugitive Dust (cont.):		Fugitive Dust (cont.):	a. Moisten soil not more than 15 minutes prior to moving soil or conduct whatever watering is necessary to prevent visible dust emissions from traveling more than 100 feet in any direction.	See above	See above		Each PA			
555.2		EIR 589	SC 4.7-1 (cont.)	See above	Fugitive Dust (cont.):		Fugitive Dust (cont.):	b. Apply chemical stabilizers to disturbed surface areas (i.e., completed grading areas) within five days of completing grading or apply dust suppressants or vegetation sufficient to maintain a stabilized surface.	See above	See above		Each PA			
555.3		EIR 589	SC 4.7-1 (cont.)	See above	Fugitive Dust (cont.):		Fugitive Dust (cont.):	c. Water excavated soil piles hourly or cover with temporary coverings.	See above	See above		Each PA			
555.4		EIR 589	SC 4.7-1 (cont.)	See above	Fugitive Dust (cont.):		Fugitive Dust (cont.):	d. Water exposed surfaces at least twice a day under calm conditions. Water as often as needed on windy days when winds are less than 25 miles per day or during very dry weather in order to maintain a surface crust and prevent the release of visible emissions from the construction site.	See above	See above		Each PA			
555.5		EIR 589	SC 4.7-1 (cont.)	See above	Fugitive Dust (cont.):		Fugitive Dust (cont.):	e. Wash mud-covered tires and undercarriages of trucks leaving construction sites.	See above	See above		Each PA			
555.5		EIR 589	SC 4.7-1 (cont.)	See above	Fugitive Dust (cont.):		Fugitive Dust (cont.):	f. Provide for street sweeping, as needed, on adjacent roadways to remove dirt dropped by construction vehicles or mud, which would otherwise be carried off by trucks departing from project sites.	See above	See above		Each PA			
556		EIR 589	SC 4.7-2	Prior to issuance of a grading permit	Construction - ROC and NOX Emissions:		Construction - ROC and NOX Emissions:	The applicant shall comply with the following measures, as feasible, to reduce NO _x and ROC from heavy equipment.	County of Orange Director of Planning & Development Services, Director, OC Planning	Place as general notes on approved grading plan		Each PA			
556.1		EIR 589	SC 4.7-2 (cont.)	See above	Construction Emissions:		Construction Emissions:	a. Turn equipment off when not in use for more than five minutes.	See above	See above		Each PA			
556.2		EIR 589	SC 4.7-2 (cont.)	See above	Construction Emissions (cont.):		Construction Emissions (cont.):	b. Maintain equipment engines in good condition and in proper tune as per manufacturers' specifications.	See above	See above		Each PA			
556.3		EIR 589	SC 4.7-2 (cont.)	See above	Construction Emissions (cont.):		Construction Emissions (cont.):	c. Lengthen the construction period during smog season (May through October) to minimize the number of vehicles and equipment operating at the same time.	See above	See above		Each PA			

Item No.	Cross Reference Column	Source	Condition, Mitigation, Public Benefit or Entitlement Provision	Timing	Subject	Keywords	Title	Requirements or Entitlement Provisions	Reviewing / Approving Authority (Advisory Agency in Parentheses)	Form of Compliance	Guidance for Compliance	Area Application	Applicant Comments	County Comments	Satisfied or Not Satisfied Y/N
557		EIR 589	SC 4.8-1	Prior to the issuance of grading permits	Hours of Construction:		Hours of Construction:	During construction, the project applicant shall ensure that all noise generating activities be limited to the hours of 7 a.m. to 8 p.m. on weekdays and Saturdays. No noise generating activities shall occur on Sundays and holidays in accordance with the County of Orange Noise Ordinance.	County of Orange Director of Planning & Development Services, Director, OC Planning	General note on approved grading plan		Each PA			
558		EIR 589	SC 4.8-2	Prior to the issuance of grading permits	Construction Noise:		Construction Noise:	A. Prior to the issuance of any grading permits, the project proponent shall produce evidence acceptable to the Manager, Building Permits Services, that: (County Standard Condition N10)	County of Orange Director of Planning & Development Services, Director, OC Planning	General note on approved grading plan		Each PA			
558.1		EIR 589	SC 4.8-2 (cont.)	See above	Construction Noise (cont.):		Construction Noise (cont.):	(1) All construction vehicles or equipment, fixed or mobile, operated within 1,000' of a dwelling shall be equipped with properly operating and maintained mufflers. (County Standard Condition N10)	See above	See above		Each PA			
558.2		EIR 589	SC 4.8-2 (cont.)	See above	Construction Noise (cont.):		Construction Noise (cont.):	(2) All operations shall comply with Orange County Codified Ordinance Division 6 (Noise Control). (County Standard Condition N10)	See above	See above		Each PA			
558.3		EIR 589	SC 4.8-2 (cont.)	See above	Construction Noise (cont.):		Construction Noise (cont.):	(3) Stockpiling and/or vehicle staging areas shall be located as far as practicable from dwellings. (County Standard Condition N10)	See above	See above		Each PA			
558.4		EIR 589	SC 4.8-2 (cont.)	See above	Construction Noise (cont.):		Construction Noise (cont.):	B. Notations in the above format, appropriately numbered and included with other notations on the front sheet of the project's permitted grading plans, will be considered as adequate evidence of compliance with this condition. (County Standard Condition N10)	See above	See above		Each PA			
559		EIR 589	SC 4.8-3	See below	Sound Attenuation:		Sound Attenuation:	The applicant shall sound attenuate all residential lots and dwellings against present and projected noise (which shall be the sum of all noise impacting the project) so that the composite interior standard of 45 dBA CNEL for habitable rooms and a source specific exterior standard of 65 dBA CNEL for outdoor living areas is not exceeded. The applicant shall provide a report prepared by a County-certified acoustical consultant, which demonstrates that these standards will be satisfied in a manner consistent with Zoning Code Section 7-9-137.5, as follows: (County Standard Condition N01)	County of Orange Director of Planning & Development Services and County of Orange Manager of Building Permits Services, Director, OC Planning and Manager, Permit Services (Building Plan Check)	Submittal of satisfactory acoustical analysis	Staff may determine that no attenuation is necessary, and no action is required (as occurred in PA1). In such a case a "not applicable" memo is to be prepared. Applicant and County staff to address AC units in side yards as soon as possible.	Each PA			

Item No.	Cross Reference Column	Source	Condition, Mitigation, Public Benefit or Entitlement Provision	Timing	Subject	Keywords	Title	Requirements or Entitlement Provisions	Reviewing / Approving Authority (Advisory Agency in Parentheses)	Form of Compliance	Guidance for Compliance	Area Application	Applicant Comments	County Comments	Satisfied or Not Satisfied Y/N
559.1		EIR 589	SC 4.8-3 (cont.)	Prior to the recordation of a subdivision map or prior to the issuance of grading permits	Sound Attenuation (cont.):		Sound Attenuation (cont.):	a. Prior to the recordation of a subdivision map or prior to the issuance of grading permits, as determined by the Manager, Building Permits Services, the applicant shall submit an acoustical analysis report to the Manager, Building Permits Services, for approval. The report shall describe in detail the exterior noise environment and preliminary mitigation measures. Acoustical design features to achieve interior noise standards may be included in the report in which case it may also satisfy Condition B below. (County Standard Condition N01)	See above	See above		Each PA			
567		EIR 589	SC 4.10-2	Prior to the issuance of precise grading permits	Private Area Landscaping:		Private Area Landscaping:	a. Prior to the issuance of precise grading permits, the applicant shall prepare a detailed landscape plan for privately maintained common areas which shall be reviewed and approved by the Manager, Subdivision and Grading. The plan shall be certified by a licensed landscape architect or a licensed landscape contractor, as required, as taking into account the approved preliminary landscape plan (if any), County Standard Plans for landscape areas, adopted plant palette guides, applicable scenic and specific plan requirements, Water Conservation Measures contained in Board Resolution 90-487 (Water Conservation Measures), and Board Resolution 90-1341 (Water Conservation Implementation Plan). (County Standard Condition LA02b)	County of Orange Director of Planning & Development Services, Director, OC Planning	Approved detailed landscape plan for privately maintained common areas		Each PA			
571	172-176 (MM 4.11-3)	EIR 589	SC 4.11-1	Prior to the issuance of any grading permits	Archaeology Grading Observation and Salvage:		Archaeology Grading Observation and Salvage:	Prior to the issuance of any grading permit, the applicant shall provide written evidence to the County of Orange Manager, Subdivision and Grading, that applicant has retained a County-certified archaeologist to observe grading activities and salvage and catalogue archaeological resources as necessary. The archaeologist shall be present at the pre-grade conference; shall establish procedures for archaeological resource surveillance; and shall establish, in cooperation with the applicant, procedures for temporarily halting or redirecting work to permit the sampling, identification, and evaluation of the artifacts as appropriate. If the archaeological resources are found to be significant, the archaeological observer shall determine appropriate actions, in cooperation with the project applicant, for exploration and/or salvage. (County Standard Condition A04)	County of Orange Manager, Harbors, Beaches & Parks HBP/Coastal and Historical Facilities — OC Public Works/OC Planning*	Written evidence that a County-certified archaeologist has been retained to observe grading and salvage, and to catalogue archaeological resources	If prior to rough grade (GA permit) applicant has obtained archaeological clearance, no additional review or clearance required if precise grading (GB) permit is in compliance with GA permit.	Each PA			

Item No.	Cross Reference Column	Source	Condition, Mitigation, Public Benefit or Entitlement Provision	Timing	Subject	Keywords	Title	Requirements or Entitlement Provisions	Reviewing / Approving Authority (Advisory Agency in Parentheses)	Form of Compliance	Guidance for Compliance	Area Application	Applicant Comments	County Comments	Satisfied or Not Satisfied Y/N
574		EIR 589	SC 4.11-2	Prior to the issuance of any grading permits	Paleontology Resource Surveillance:		Paleontology Resource Surveillance:	Prior to the issuance of any grading permit, the project contractor shall provide written evidence to the Manager, Subdivision and Grading, that contractor has retained a County certified paleontologist to observe grading activities and salvage and catalogue fossils as necessary. The paleontologist shall be present at the pre-grade conference, shall establish procedures for paleontological resources surveillance, and shall establish, in cooperation with the contractor, procedures for temporarily halting or redirecting work to permit sampling, identification, and evaluation of the fossils. If the paleontological resources are found to be significant, the paleontologist shall determine appropriate actions, in cooperation with the contractor, which ensure proper exploration and/or salvage. (County Standard Condition A07)	County of Orange Manager, Harbors, Beaches & Parks, HBP/Coastal and Historical Facilities OC Public Works/OC Planning*	Written evidence that a County-certified archaeologist has been retained to observe grading and salvage, and to catalogue fossils as necessary		Each PA			
589		EIR 589	SC 4.14-2	Prior to issuance of a grading and/or building permit	Hazardous Materials:		Hazardous Materials:	Prior to the issuance of a grading or building permit, the contractor shall submit to the Fire Chief a list of all hazardous, flammable and combustible liquids, solids or gases to be stored, used or handled on site. These materials shall be classified according to the Uniform Fire Code and a document submitted to the Fire Chief with a summary sheet listing the totals for storage and use for each hazard class. (County Standard Condition FPC11A)	County of Orange Director of Planning & Development Services Director, OC Planning (OCFA)	Submittal of Hazardous Materials Assessment and Disclosure Statement		Each PA			
616		Fire Prot. Prog.	Cond. 3.d.	Prior to the issuance of a GB precise grading permit	Precise Fuel Mod:		Precise Fuel Mod:	d) Prior to the issuance of a GB precise grading permit, the applicant shall provide the Manager, PDS Subdivision and Infrastructure Manager OC Planned Communities , with a clearance from OCFA indicating their review and approval of a Precise Fuel Modification Plan per RPFPP Section C.3.	Director, PDS, Director, OC Planning	Provide the Manager, PDS Subdivision and Infrastructure Manager OC Planned Communities with a clearance from OCFA demonstrating approval of a Conceptual Fuel Modification Plan					

* In Coordination with Manager, Land Development

Item No.	Cross Reference Column	Source	Condition, Mitigation, Public Benefit or Entitlement Provision	Timing	Subject	Keywords	Title	Requirements or Entitlement Provisions	Reviewing / Approving Authority (Advisory Agency in Parentheses)	Form of Compliance	Guidance for Compliance	Area Application	Applicant Comments	County Comments	Satisfied or Not Satisfied Y/N
COA# 2		PA2.3 Builder "B" Map COAs		Prior to the issuance of any grading or building permits	WQMP			Prior to the issuance of any grading or building permits, the applicant shall submit for review and approval by the Manager, Permit Services, a Water Quality Management Plan (WQMP) specifically identifying Best Management Practices (BMPs) that will be used onsite to control predictable pollutant runoff. The applicant shall utilize the Orange County Drainage Area Management Plan (DAMP), Model WQMP, and Technical Guidance Manual for reference, and the County's WQMP template for submittal.	County of Orange Manager, Building Inspection Services, Manager, OC Inspection Division			Each PA			
COA# 2 (cont.)		PA2.2 Builder "B" Map COAs		See above	WQMP			This WQMP shall include the following: - Detailed site and project description - Potential stormwater pollutants - Post-development drainage characteristics - Low Impact Development (LID) BMP selection and analysis - Structural and Non-Structural source control BMPs - Site design and drainage plan (BMP Exhibit) - GIS coordinates for all LID and Treatment Control BMPs - Operation and Maintenance (O&M) Plan that (1) describes the long-term operation and maintenance requirements for BMPs identified in the BMP Exhibit; (2) identifies the entity that will be responsible for long-term operation and maintenance of the referenced BMPs; and (3) describes the mechanism for funding the long-term operation and maintenance of the referenced BMPs The BMP Exhibit from the approved WQMP shall be included as a sheet in all plan sets submitted for plan check and all BMPs shall be depicted on these plans. Grading and building plans must be consistent with the approved BMP exhibit.	County of Orange Manager, Building Inspection Services, Manager, OC Inspection Division			Each PA			

Item No.	Cross Reference Column	Source	Condition, Mitigation, Public Benefit or Entitlement Provision	Timing	Subject	Keywords	Title	Requirements or Entitlement Provisions	Reviewing / Approving Authority (Advisory Agency in Parentheses)	Form of Compliance	Guidance for Compliance	Area Application	Applicant Comments	County Comments	Satisfied or Not Satisfied Y/N
d. Prior to Precise Fuel Modification Plans															
138	137 and 139 (EIR 589, MM 4.9-27) 514 (ROSA Exhibit G)	EIR 589	MM 4.9-27 (cont.)	Prior to the approval of Precise Fuel Modification Plans	Biological Resources	California Exotic Pest Plant Council, OCFA Fuel Modification Plant List	Invasive Plants and Fuel Modification	a. Prior to issuance of fuel modification plan approvals, the County of Orange shall verify that: 1) plants identified by the California Exotic Pest Plant Council as an invasive risk in Southern California are not included in plans for fuel management zones adjacent to the RMV Open Space and, 2) the plant palette for fuel management zones adjacent to RMV Open Space is limited to those species listed on the Orange County Fire Authority Fuel Modification Plant List.	Director, PDS-Director, OC Planning (OCFA)	Verification of authorized plant materials	Signature of Landscape Architect on approved Precise Fuel Modification Plan certifying plant palette: (a) complies with current OCFA plant list, and (b) does not include plants listed on the current invasive species list.	Each PA			
e. Prior to Issuance of Building Permit															
111	110 (MM 4.7-3)	EIR 589	MM 4.7-3 (cont.)	Prior to issuance of building permits	Air Quality	Light-colored roof materials	Use Light-Colored Roof Materials to Reflect Heat (Item Nos. 110-111)	Prior to issuance of building permits, the applicant shall identify how the use of light-colored roof materials and paint to reflect heat to the extent feasible has been incorporated into the design plans.	Director, PDS-Director, OC Planning	Issuance of Building Permit (Evidence of reflection of heat through home design)	Sustainability Issue	Each PA			
140	141 (MM 4.9-28) 515 (ROSA Exhibit G)	EIR 589	MM 4.9-28	Prior to the issuance of Building permits on streets for tracts with public street lighting adjacent to RMV Open Space habitat areas	Biological Resources	Open Space habitat, light shields	Streetslight Shielding Adjacent to Open Space	Lighting shall be shielded or directed away from RMV Open Space habitat areas through the use of low-sodium or similar intensity lights, light shields, native shrubs, berms or other shielding methods.	Director, PDS-Director, OC Planning	Preparation of a lighting plan	Preparation of street improvement plans for public streets that detail how street lighting is to be directed away from RMV Open Space areas	Each Applicable PA			
206		EIR 589	MM 4.15-5	Prior to issuance of residential building permits (excluding age-qualified units)	Public Services and Facilities	California Government Code Section 65995	CUSD Agreement	Prior to issuance of any residential building permit, excluding senior housing, the applicant shall enter into an agreement with CUSD regarding the development of future facilities and payment of costs. The agreement shall, at a minimum, provide for the payment of fees pursuant to California Government Code Section 65995. If fees are paid, the amount of fees to be paid will be determined based on the established State formula for determining construction costs. Applicable fees shall be paid prior to the issuance of each building permit.	Capistrano Unified School District (CUSD)	Negotiate and execute Mitigation Agreement regarding future school facilities and payment of costs		PC-Wide			
526		EIR 589	SC 4.4-5	Prior to the issuance of building permits	Geology and Soils (cont.):		Geology and Soils (cont.):	The proposed development shall be designed in compliance with the Uniform Building Code (UBC), accepted industry standards, and the County's earthquake safety Municipal Code requirements.	County of Orange Director of Planning & Development Services, Director, OC Planning	Verification of design development compliance with the UBC and Municipal Code requirements		Each PA			

Item No.	Cross Reference Column	Source	Condition, Mitigation, Public Benefit or Entitlement Provision	Timing	Subject	Keywords	Title	Requirements or Entitlement Provisions	Reviewing / Approving Authority (Advisory Agency in Parentheses)	Form of Compliance	Guidance for Compliance	Area Application	Applicant Comments	County Comments	Satisfied or Not Satisfied Y/N
537		EIR 589	SC 4.5-8	Prior to the recordation of a Subdivision Map or the issuance of any Grading or Building Permit, whichever comes first	Water Quality Management Plan:		Water Quality Management Plan:	Prior to the recordation of any final subdivision map (except those maps for financing or conveyance purposes only) or the issuance of any grading or building permit (whichever comes first), the applicant shall submit for review and approval by the Manager, Inspection Services Division, a Water Quality Management Plan (WQMP) specifically identifying Best Management Practices (BMPs) that will be used onsite to control predictable pollutant runoff. This WQMP shall identify, at a minimum, the routine structural and non-structural measures specified in the current Drainage Area Management Plan (DAMP). The WQMP may include one or more of the following: (County Standard Condition WQ01)	County of Orange Director of Planning & Development Services, Director, OC Planning	Submittal of satisfactory Water Quality Management Plan		Each PA			
537.1		EIR 589	SC 4.5-8 (cont.)	See above	Water Quality Management Plan (cont.):		Water Quality Management Plan (cont.):	<ul style="list-style-type: none"> • Discuss regional water quality and/or watershed programs (if available for the project); • Address Site Design BMPs (as applicable) such as minimizing impervious areas, maximizing permeability, minimizing directly connected impervious areas, creating reduced or "zero discharge" areas, and conserving natural areas; • Include the applicable Routine Source Control BMPs as defined in the DAMP. (County Standard Condition WQ01) 	See above	See above		Each PA			
538		EIR 589	SC 4.5-8 (cont.)	See above	Water Quality Management Plan (cont.):		Water Quality Management Plan (cont.):	Demonstrate how surface runoff and subsurface drainage shall be managed and directed to the nearest acceptable drainage facility (as applicable), via sump pumps if necessary. (Standard Condition of Approval, WQ03)	See above	See above		Each PA			
540		EIR 589	SC 4.5-10	Prior to the issuance of any Grading or Building Permits	Stormwater Pollution Prevention Plan.		Stormwater Pollution Prevention Plan.	Prior to the issuance of any grading or building permits, the applicant shall demonstrate compliance under California's General Permit for Stormwater Discharges Associated with Construction Activity by providing a copy of the Notice of Intent (NOI) submitted to the State Water Resources Control Board and a copy of the subsequent notification of the issuance of a Waste Discharge Identification (WDID) Number or other proof of filing in a manner meeting the satisfaction of the Manager, Building Permit Services. Projects subject to this requirement shall prepare and implement a Stormwater Pollution Prevention Plan (SWPPP). A copy of the current SWPPP shall be kept at the project site and be available for County review on request. (County Standard Condition WQ04)	County of Orange Manager of Building Inspection - Manager, OC Inspection Division (Regional Water Quality Control Board)	Provision of Notice of Intent and verification of a copy of the Storm Water Pollution Prevention Plan (SWPPP); at the project site		Each PA			

Item No.	Cross Reference Column	Source	Condition, Mitigation, Public Benefit or Entitlement Provision	Timing	Subject	Keywords	Title	Requirements or Entitlement Provisions	Reviewing / Approving Authority (Advisory Agency in Parentheses)	Form of Compliance	Guidance for Compliance	Area Application	Applicant Comments	County Comments	Satisfied or Not Satisfied Y/N
541		EIR 589	SC 4.5-11	Prior to the issuance of any Grading or Building Permits	Erosion and Sediment Control Plan.		Erosion and Sediment Control Plan.	Prior to the issuance of any grading or building permit, the applicant shall submit a Erosion and Sediment Control Plan (ESCP) in a manner meeting approval of the Manager, Building Permit Services, to demonstrate compliance with local and state water quality regulations for grading and construction activities. The ESCP shall identify how all construction materials, wastes, grading or demolition debris, and stockpiles of soil, aggregates, soil amendments, etc. shall be properly covered, stored, and secured to prevent transport into local drainages or coastal waters by wind, rain, tracking, tidal erosion or dispersion. The ESCP shall also describe how the applicant will ensure that all BMPs will be maintained during construction of any future public right-of-ways. A copy of the current ESCP shall be kept at the project site and be available for County review on request. (County Standard Condition WQ05)	County of Orange Manager of Building Permits, Manager, Permit Services (Building Plan Check)	Submittal of satisfactory Erosion and Sediment Control Plan (ESCP); verification of copy of ESCP at project site		Each PA			
547		EIR 589	SC 4.6-5	Prior to the issuance of Building Permits	Major Thoroughfare and Bridge Fee Programs:		Major Thoroughfare and Bridge Fee Programs:	Prior to the issuance of building permits, the applicant shall pay fees for the Major Thoroughfare and Bridge Fee Program for the Foothill/Eastern Transportation Corridor, in a manner meeting the approval of the Manager, Subdivision and Grading. (County Standard Condition T05)	County of Orange Director of Planning & Development Services, Director, OC Planning	Verification of payment of fees for the Major Thoroughfare and Bridge Fee Program		Each PA			
550		EIR 589	SC 4.6-8	Prior to the recordation of a Subdivision Map or prior to the issuance of Building Permits, whichever occurs first	Internal Circulation:		Internal Circulation:	A. Prior to the recordation of a subdivision map or the issuance of any building permits, whichever occurs first, the subdivider shall provide plans and specifications meeting the approval of the Manager, Subdivision and Grading, for the design of the following improvements: (County Standard Condition T12)	County of Orange Director of Planning & Development Services,	Submittal of satisfactory street improvement plans		Each PA			
550.1		EIR 589	SC 4.6-8 (cont.)	See above	Internal Circulation (cont.):		Internal Circulation (cont.):	1) Internal street common private drive system. (County Standard Condition T12)	See above	See above		Each PA			
550.2		EIR 589	SC 4.6-8 (cont.)	See above	Internal Circulation (cont.):		Internal Circulation (cont.):	2) Entrance to the site to emphasize that the development is private by use of signs and other features. (Standard Condition of Approval T12)	See above	See above		Each PA			

Item No.	Cross Reference Column	Source	Condition, Mitigation, Public Benefit or Entitlement Provision	Timing	Subject	Keywords	Title	Requirements or Entitlement Provisions	Reviewing / Approving Authority (Advisory Agency in Parentheses)	Form of Compliance	Guidance for Compliance	Area Application	Applicant Comments	County Comments	Satisfied or Not Satisfied Y/N
550.4		EIR 589	SC 4.6-8 (cont.)	Prior to the issuance of Building Permits	Internal Circulation (cont.):		Internal Circulation (cont.):	C. Prior to the issuance of any building permits, the subdivider shall provide plans meeting the approval of the Manager, Subdivision & Grading, for the design of the internal pedestrian circulation system within the development. (County Standard Condition T12)	County of Orange Director of Planning & Development Services, Director, OC Planning	Submittal of satisfactory internal pedestrians circulation plans		Each PA			
559.2		EIR 589	SC 4.8-3 (cont.)	Prior to the issuance of any building permits for residential construction	Sound Attenuation (cont.):		Sound Attenuation (cont.):	b. Prior to the issuance of any building permits for residential construction, the applicant shall submit an acoustical analysis report describing the acoustical design features of the structures required to satisfy the exterior and interior noise standards to the Manager, Building Permits Services, for approval along with satisfactory evidence which indicates that the sound attenuation measures specified in the approved acoustical report have been incorporated into the design of the project. (County Standard Condition N01)	County of Orange Director of Planning & Development Services and County of Orange Manager of Building Permits Services, Director, OC Planning and Manager, Permit Services (Building Plan Check)	Submittal of satisfactory acoustical analysis		Each PA			
559.3		EIR 589	SC 4.8-3 (cont.)	See above	Sound Attenuation (cont.):		Sound Attenuation (cont.):	c. Prior to the issuance of any building permits, the applicant shall show all freestanding acoustical barriers on the project's plot plan illustrating height, location and construction in a manner meeting the approval of the Manager, Building Permits Services. (County Standard Condition N01)	See above	See above		Each PA			
564		EIR 589	SC 4.10-1	Prior to the issuance of building permits	Public Area Landscaping:		Public Area Landscaping:	The applicant shall install landscaping, equip for irrigation, and improvements on lots in accordance with an approved plan as stated below: (County Standard Condition LA01b)	County of Orange Director of Planning & Development Services in consultation with Manager, HBP, Director, OC Planning	Approved landscaping plan and irrigation plan		Each PA			

Item No.	Cross Reference Column	Source	Condition, Mitigation, Public Benefit or Entitlement Provision	Timing	Subject	Keywords	Title	Requirements or Entitlement Provisions	Reviewing / Approving Authority (Advisory Agency in Parentheses)	Form of Compliance	Guidance for Compliance	Area Application	Applicant Comments	County Comments	Satisfied or Not Satisfied Y/N
564.1		EIR 589	SC 4.10-1 (cont.)	See above	Public Area Landscaping:		Public Area Landscaping:	a. Detailed Plan--Prior to the issuance of any building permit(s), the applicant shall submit a detailed landscape plan showing the detailed irrigation and landscaping design to the Manager, Subdivision and Grading for approval, in consultation with the Manager HBP/Program Management. Detailed plans shall show the detailed irrigation and landscaping design and shall take into account the previously approved landscape plan for the Ranch Plan project, the County Standard Plans for landscape areas, adopted plant palette guides, applicable scenic and specific plan requirements, Water Conservation Measures contained in Board Resolution 90-487 (Water Conservation Measures), and Board Resolution 90-1341 (Water Conservation Implementation Plan). (County Standard Condition LA01b)	See above	See above		Each PA			
570		EIR 589	SC 4.10-3	Prior to the issuance of building permits	Light and Glare:		Light and Glare:	Prior to issuance of any building permit, the applicant shall demonstrate that all exterior lighting has been designed and located so that all direct rays are confined to the property in a manner meeting the approval of the Manager, Building Permit. (County Standard Condition LG01)	County of Orange Manager of Building Permits, Manager, Permit Services (Building Plan Check)	Approved lighting study/plan	Low voltage lighting: landscape architect is the designer can sign off on the lighting. High voltage lighting: electrical engineer stamp required.	Each PA			
589		EIR 589	SC 4.14-2	Prior to issuance of a grading and/or building permit	Hazardous Materials:		Hazardous Materials:	Prior to the issuance of a grading or building permit, the contractor shall submit to the Fire Chief a list of all hazardous, flammable and combustible liquids, solids or gases to be stored, used or handled on site. These materials shall be classified according to the Uniform Fire Code and a document submitted to the Fire Chief with a summary sheet listing the totals for storage and use for each hazard class. (County Standard Condition FPC11A)	County of Orange Director of Planning & Development Services, Director, OC Planning (OCFA)	Submittal of Hazardous Materials Assessment and Disclosure Statement		Each PA			

Item No.	Cross Reference Column	Source	Condition, Mitigation, Public Benefit or Entitlement Provision	Timing	Subject	Keywords	Title	Requirements or Entitlement Provisions	Reviewing / Approving Authority (Advisory Agency in Parentheses)	Form of Compliance	Guidance for Compliance	Area Application	Applicant Comments	County Comments	Satisfied or Not Satisfied Y/N
617		Fire Prot. Prog.	Cond. 3.e.	Prior to the issuance of a building permit for construction phases of Vesting Tentative Tract Maps adjoining fuel modification areas, and prior to the County of Orange allowing fuel tanks, generators and/or Lumber Drops	Vegetation Clearance:		Vegetation Clearance:	e) Prior to the issuance of a building permit for construction phases of Vesting Tentative Tract Maps adjoining fuel modification areas, and prior to the County of Orange allowing fuel tanks, generators and/or Lumber Drops (see Section E, Definitions) within the project site, the applicant shall provide the Manager, Building & Safety, with a clearance from OCFA indicating that vegetation has been cleared and maintained at a height of 8 inches or less, or that the appropriate fuel modification thinning and removal of plants from the OCFA Undesirable Plant List has been implemented.	Director, PDS, Director, OC Planning	Provide the Manager, Building & Safety, with a clearance from OCFA indicating that vegetation has been cleared and maintained					
COA# 3		PA2.3 Builder "B" Map COAs	Cond. #3	Prior to the issuance of a building permit			BEST MANAGEMENT PRACTICES	Prior to issuance of a building permit, the off-site regional Best Management Practices (BMPs) relied upon by this project (e.g., basins, swales, etc.) must be built and/or installed, and operational. The location and operation of these regional BMPs must be in compliance with the Final Project-Specific WQMP for the regional BMP(s). The location and operation of the regional BMP(s) must be demonstrated to the satisfaction of the Manager, Grading and Building Plan Check.	Director, PDS, Manager, Permit Services (Building Plan Check)						
COA# 6		PA2.3 Builder "B" Map COAs	Cond. #6	Prior to the issuance of a building permit			BUYER NOTIFICATION MAP	Prior to the issuance of any building permits for residential construction, the developer RMV Community Development, LLC, shall prepare a map denoting the existing and proposed land uses, arterial highways, and public facilities within the surrounding area for the approval of the Manager, OC Planning. The map content, display, and distribution shall be in accordance with the Buyer Notification Program guidelines listed in Board of Supervisors Resolution 82-1368 and as amended.	Director, PDS, Director, OC Planning						

Item No.	Cross Reference Column	Source	Condition, Mitigation, Public Benefit or Entitlement Provision	Timing	Subject	Keywords	Title	Requirements or Entitlement Provisions	Reviewing / Approving Authority (Advisory Agency in Parentheses)	Form of Compliance	Guidance for Compliance	Area Application	Applicant Comments	County Comments	Satisfied or Not Satisfied Y/N
f. Prior to Combustible Construction															
609			Cond. 2.d.	Prior to initiation of combustible construction	A Map Fire Master Plan (cont.):		A Map Fire Master Plan (cont.):	d) Prior to initiation of combustible construction the following fire master plan improvements shall be verified by site inspection: • Emergency access • Water Supply	Director, PDS, Director, OC Planning	Site inspection					
g. During Construction															
197	196 (EIR 589, MM 4.14-13)	EIR 589	MM 4.14-13 (cont.)	During construction	Hazards and Hazardous Materials	Remedial measures	ESA Remedial Measures	If soil is encountered during site development that is suspected of being impacted by hazardous materials, work will be halted and site conditions will be evaluated by a qualified environmental professional. If requested by the qualified environmental professional, the results of the evaluation will be submitted to OCHCA and/or RWQCB, and the appropriate remedial measures will be implemented, as directed by OCHCA, RWQCB, or other applicable oversight agency, until all specified requirements of the oversight agencies are satisfied and a no-further-action status is attained.	Director, PDS- Director, OC Planning (Orange County Health Care Agency)	Stop work upon encountering condition; prepare evaluation and submit to OCHCA and/or RWQCB (as directed)		Each PA			
h. Prior to Issuance of Certificates of Occupancy															
529		EIR 589	SC 4.5-2 (cont.)	Prior to recordation of a Subdivision Map or Issuance of a Certificate of Use and Occupancy, whichever comes first	Drainage Improvements (cont.):		Drainage Improvements (cont.):	B. Prior to the recordation of a subdivision map (except maps for financing and conveyance purposes only) or prior to the issuance of any certificates of use and occupancy, whichever occurs first, said improvements shall be constructed in a manner meeting the approval of the Manager, Construction. (County Standard Condition D02a)	County of Orange Manager of Inspection, Manager, OC Inspection Division	Verification of construction of drainage improvement		Each PA			
531		EIR 589	SC 4.5-3 (cont.)	Prior to the issuance of Certificates of Use and Occupancy	Drainage Improvements (cont.):		Drainage Improvements (cont.):	B. Prior to the issuance of any certificates of use and occupancy, said improvements shall be constructed in a manner meeting the approval of the Manager, Construction. (County Standard Condition D02b)	County of Orange Manager of Inspection, Manager, OC Inspection Division	Verification of installation of drainage improvement		Each PA			

Item No.	Cross Reference Column	Source	Condition, Mitigation, Public Benefit or Entitlement Provision	Timing	Subject	Keywords	Title	Requirements or Entitlement Provisions	Reviewing / Approving Authority (Advisory Agency in Parentheses)	Form of Compliance	Guidance for Compliance	Area Application	Applicant Comments	County Comments	Satisfied or Not Satisfied Y/N
539		EIR 589	SC 4.5-9	Prior to the issuance of a Certificate of Use and Occupancy	Compliance with the WQMP:		Compliance with the WQMP:	Prior to the issuance of a certificate of use and occupancy, the applicant shall demonstrate compliance with the WQMP in a manner meeting the satisfaction of the Manager, Inspection Services Division, including: <ul style="list-style-type: none"> • Demonstrate that all structural Best Management Practices (BMPs) described in the project's WQMP have been implemented, constructed and installed in conformance with approved plans and specifications; • Demonstrate that the applicant has complied with all non-structural BMPs described in the project's WQMP; • Submit for review and approval an Operations and Maintenance (O&M) Plan for all structural BMPs for attachment to the WQMP; 	County of Orange Manager of Building Inspection, Manager, OC Inspection Division	Verification of compliance with Water Quality Management Plan		Each PA			
539.1		EIR 589	SC 4.5-9 (cont.)	See above	Water Quality Management Plan (cont.):		Water Quality Management Plan (cont.):	<ul style="list-style-type: none"> • Demonstrate that copies of the project's approved WQMP (with attached O&M Plan) are available for each of the incoming occupants; • Agree to pay for a Special Investigation from the County of Orange for a date (12) twelve months after the issuance of a Certificate of Use and Occupancy for the project to verify compliance with the approved WQMP and O&M Plan; and (County Standard Condition WQ03) 	See above	See above		Each PA			
539.2		EIR 589	SC 4.5-9 (cont.)	See above	Water Quality Management Plan (cont.):		Water Quality Management Plan (cont.):	<ul style="list-style-type: none"> • Demonstrate that the applicant has agreed to and recorded one of the following: 1) the CC&R's (that must include the approved WQMP and O&M Plan) for the project Home Owner's Association; 2) a water quality implementation agreement that has the approved WQMP and O&M Plan attached; or 3) the final approved Water Quality Management Plan (WQMP) and Operations and Maintenance (O&M) Plan. (County Standard Condition WQ03) 	See above	See above		Each PA			

Item No.	Cross Reference Column	Source	Condition, Mitigation, Public Benefit or Entitlement Provision	Timing	Subject	Keywords	Title	Requirements or Entitlement Provisions	Reviewing / Approving Authority (Advisory Agency in Parentheses)	Form of Compliance	Guidance for Compliance	Area Application	Applicant Comments	County Comments	Satisfied or Not Satisfied Y/N
560		EIR 589	SC 4.8-4	Prior to the issuance of certificates of use and occupancy	Multi-Family Residential Development:		Multi-Family Residential Development:	Prior to the issuance of any certificates of use and occupancy, the applicant shall perform field testing in accordance with Title 24 Regulations to verify compliance with FSTC and FIC standards if determined necessary by the Manager, Building Inspection Services. In the event such a test was previously performed, the applicant shall provide satisfactory evidence and a copy of the report to the Manager, Building Inspection Services, as a supplement to the previously required acoustical analysis report. (County Standard Condition N09)	County of Orange Manager of Building Inspection Services, Manager, OC Inspection Division	Verification of field testing in accordance with Title 24 Regulations to verify compliance with FSTC and FIC standards or a copy of a previous test		Each PA			
563		EIR 589	SC 4.8-7	Prior to the issuance of certificates of use and occupancy	Transportation Corridor Notification:		Transportation Corridor Notification:	Prior to the issuance of certificates of use and occupancy, the developer shall produce evidence to the Manager, Building Inspection Services, that the Department of Real Estate has been notified that the project area is adjacent to a regional transportation corridor. The corridor is expected to be a high capacity, high-speed, limited-access facility for motor vehicles, and will have provisions for bus lanes and other mass transit type facilities. (County Standard Condition N12)	County of Orange Manager of Building Inspection Services, Manager, OC Inspection Division	Submission of evidence that County of Orange Dept. of Real Estate has been notified the project area is adjacent to a regional transportation corridor		Each PA			
565		EIR 589	SC 4.10-1 (cont.)	Prior to the issuance of final certificates of use and occupancy and the release of financial security	Public Area Landscaping (cont.):		Public Area Landscaping (cont.):	b. Installation Certification: Prior to the issuance of final certificates of use and occupancy and the release of financial security, if any, guaranteeing the landscape improvements, said improvements shall be installed and shall be certified by a licensed landscape architect or licensed landscape contractor, as having been installed in accordance with the approved detailed plans. (County Standard Condition LA01b)	County of Orange Director of Planning & Development Services & Manager HBP, Director, OC Planning	Landscaping and irrigation plan certification from landscape architect		Each PA			
566		EIR 589	SC 4.10-1 (cont.)	Prior to the issuance of final certificates of use and occupancy and the release of financial security	Public Area Landscaping (cont.):		Public Area Landscaping (cont.):	b. Installation Certification (cont): The applicant shall furnish said certification, including an irrigation management report for each landscape irrigation system, and any other required implementation report determined applicable, to the Manager, Construction, and the Manager, Building Inspection Services, prior to the issuance of any certificates of use and occupancy. (County Standard Condition LA01b)	County of Orange Manager of Construction and Manager of Building Inspection Services, Manager, OC Inspection Division	Approved irrigation management report		Each PA			

Item No.	Cross Reference Column	Source	Condition, Mitigation, Public Benefit or Entitlement Provision	Timing	Subject	Keywords	Title	Requirements or Entitlement Provisions	Reviewing / Approving Authority (Advisory Agency in Parentheses)	Form of Compliance	Guidance for Compliance	Area Application	Applicant Comments	County Comments	Satisfied or Not Satisfied Y/N
568		EIR 589	SC 4.10-2 (cont.)	Prior to the issuance of certificates of use and occupancy	Private Area Landscaping (cont.):		Private Area Landscaping (cont.):	b. Prior to the issuance of certificates of use and occupancy, applicant shall install said landscaping and irrigation system and shall have a licensed landscape architect or licensed landscape contractor, certify that it was installed in accordance with the approved plan. (County Standard Condition LA02b)	County of Orange Director of Planning & Development Services, Director, OC Planning	Certification from landscape architect that landscaping and irrigation system in accordance with the approved plan		Each PA			
569		EIR 589	SC 4.10-2 (cont.)	Prior to the issuance of certificates of use and occupancy	Private Area Landscaping (cont.):		Private Area Landscaping (cont.):	c. Prior to the issuance of any certificates of use and occupancy, the applicant shall furnish said installation certification, including an irrigation management report for each landscape irrigation system, and any other implementation report determined applicable, to the Manager, Building Inspection Services. (County Standard Condition LA02b)	County of Orange Manager, Building Inspection Services, Manager, OC Inspection Division	Approved irrigation management report for each landscape irrigation system		Each PA			
618		Fire Prot. Prog.	Cond. 3.f.	Prior to the issuance of any certificate of use and occupancy adjoining fuel modification areas	Occupancy Requirements:		Occupancy Requirements:	f) Prior to the issuance of any certificate of use and occupancy, the applicant shall provide the Manager, Building & Safety, with a clearance from OCFA indicating that: 1. Approved "A" Zone planting has been installed and approved irrigation has been activated. 2. Approved fuel modification zone markers have been installed. 3. Accessways every 500 feet (or as approved) have been installed. 4. Approved thinning of the "B" and "C" Zones and removal of plants from the OCFA Undesirable Plant List have been completed. 5. CC&Rs or other approved documents contain provisions for maintaining the fuel modification zones.	Director, PDS, Director, OC Planning	Provide the Manager, Building & Safety, with a clearance from OCFA indicating installation and thinning					

Item No.	Cross Reference Column	Source	Condition, Mitigation, Public Benefit or Entitlement Provision	Timing	Subject	Keywords	Title	Requirements or Entitlement Provisions	Reviewing / Approving Authority (Advisory Agency in Parentheses)	Form of Compliance	Guidance for Compliance	Area Application	Applicant Comments	County Comments	Satisfied or Not Satisfied Y/N
i. Prior to Release of Grading Bond															
572		EIR 589	SC 4.11-1 (cont.)	Prior to the release of the grading bond	Archaeology Grading Observation and Salvage (cont.):		Archaeology Grading Observation and Salvage (cont.):	Prior to the release of the grading bond, the applicant shall obtain approval of the archaeologist's follow-up report from the Manager, Harbors, Beaches & Parks HBP/Coastal and Historical Facilities. The report shall include the period of inspection, an analysis of any artifacts found and the present repository of the artifacts. Applicant shall prepare excavated material to the point of identification. Applicant shall offer excavated finds for curatorial purposes to the County of Orange, or its designee, on a first refusal basis. (County Standard Condition A04)	County of Orange Manager, Harbors, Beaches & Parks HBP/Coastal and Historical Facilities OC Public Works/OC Planning*	Approval of the archaeologist's follow-up report		Each PA			
573		EIR 589	SC 4.11-1 (cont.)	Prior to the release of the grading bond	Archaeology Grading Observation and Salvage (cont.):		Archaeology Grading Observation and Salvage (cont.):	These actions, as well as final mitigation and disposition of the resources shall be subject to the approval of the Manager, HBP/Coastal and Historical Facilities. Applicant shall pay curatorial fees if an applicable fee program has been adopted by the Board of Supervisor, and such fee program is in effect at the time of presentation of the materials to the County of Orange or its designee, all in a manner meeting the approval of the Manager, HBP/Coastal and Historical Facilities. (County Standard Condition A04)	County of Orange Manager, Harbors, Beaches & Parks HBP/Coastal and Historical Facilities OC Public Works/OC Planning*	Verification of payment of curatorial fee if an applicable fee program has been adopted by the Board of Supervisor at the time of presentation		Each PA			
575		EIR 589	SC 4.11-2 (cont.)	Prior to the release of the grading bond	Paleontology Resource Surveillance (cont.):		Paleontology Resource Surveillance (cont.):	Prior to the release of any grading bond, the contractor shall submit the paleontologist's follow up report for approval by the County Manager, HBP/Coastal and Historical Facilities. The report shall include the period of inspection, a catalogue and analysis of the fossils found, and the present repository of the fossils. The contractor shall prepare excavated material to the point of identification. The contractor shall offer excavated finds for curatorial purposes to the County of Orange, or its designee, on a first-refusal basis. (County Standard Condition A07)	County of Orange Manager, Harbors, Beaches & Parks HBP/Coastal and Historical Facilities OC Public Works/OC Planning*	Approval of the paleontologist's follow-up report		Each PA			
576		EIR 589	SC 4.11-2 (cont.)	Prior to the release of the grading bond	Paleontology Resource Surveillance (cont.):		Paleontology Resource Surveillance (cont.):	These actions, as well as final mitigation and disposition of the resources, shall be subject to approval by the HBP/Coastal and Historical Facilities. The contractor shall pay curatorial fees if an applicable fee program has been adopted by the Board of Supervisors, and such fee program is in effect at the time of presentation of the materials to the County of Orange or its designee, all in a manner meeting the approval of the County Manager, HBP/Coastal and Historical Facilities. (County Standard Condition A07)	County of Orange Manager, Harbors, Beaches & Parks HBP/Coastal and Historical Facilities OC Public Works/OC Planning*	Verification of curatorial fee if an applicable fee program has been adopted by the Board of Supervisor at the time of presentation		Each PA			

ATTACHMENT 1



HUNSAKER & ASSOCIATES

IRVINE . INC .

PLANNING
ENGINEERING
SURVEYING
GOVERNMENT RELATIONS

IRVINE
LOS ANGELES
RIVERSIDE
SAN DIEGO

April 7, 2020

Orange County Public Works
601 N. Ross Street
Santa Ana, CA 92703
Attn: Bea Bea Jimenez, Division Manager – Land Development

RE: TTM 19108 STORM DRAIN IMPROVEMENTS – DRAINAGE TECHNICAL MEMORANDUM

Ms. Jimenez:

Thank you for informing us of the items required for a complete submittal for the Tentative Tract above. Per your direction, Hunsaker & Associates, Irvine has prepared this technical drainage memorandum, with attachments, to be incorporated with the tentative tract submittal. These items include;

PRINCIPALS:
FRED GRAYLEE
BRADLEY HAY
PAUL HUDDLESTON
KAMAL H. KARAM
DOUGLAS L. STALEY
KRIS WEBER
JOSEPH E. WIGHTMAN

- STP19-0004 Revision 1 Street and Storm Drain Improvements TR17605 (for reference)
- STP19-0004 Hydrology and Hydraulic Analysis Tract 17605 (for reference)
- CB#103a inlet calculation
- TR19108 Line A Hydraulic Analysis
- TR19108 Line A-5b Hydraulic Analysis

In regards to the drainage of this site, two of the previously installed flow-by catch basins will be replaced by a single sump inlet. Tributary drainage areas are essentially unchanged, since the proposed cul-de-sacs are situated at the existing inlet locations. Analysis of the mainline indicates no significant impact to the storm drain hydraulic grade line (HGL).

Respectfully submitted,

FOUNDING PARTNERS:
RICHARD HUNSAKER
TOM R. McGANNON
JOHN A. MICHLER
DOUGLAS G. SNYDER

Patrick L. Pagaduan, P.E.



Attachments

Three Hughes
Irvine, California
92618-2021
(949) 583-1010 PH
(949) 583-0759 FX
www.hunsaker.com

Cc: Matthew Blain, New Home Company
Farhad Mohammadi, Hunsaker & Associates
Sepideh Bastani, Hunsaker & Associates
John Pham, Hunsaker & Associates

ATTACHMENT 2

PROJECT SITE EXHIBIT

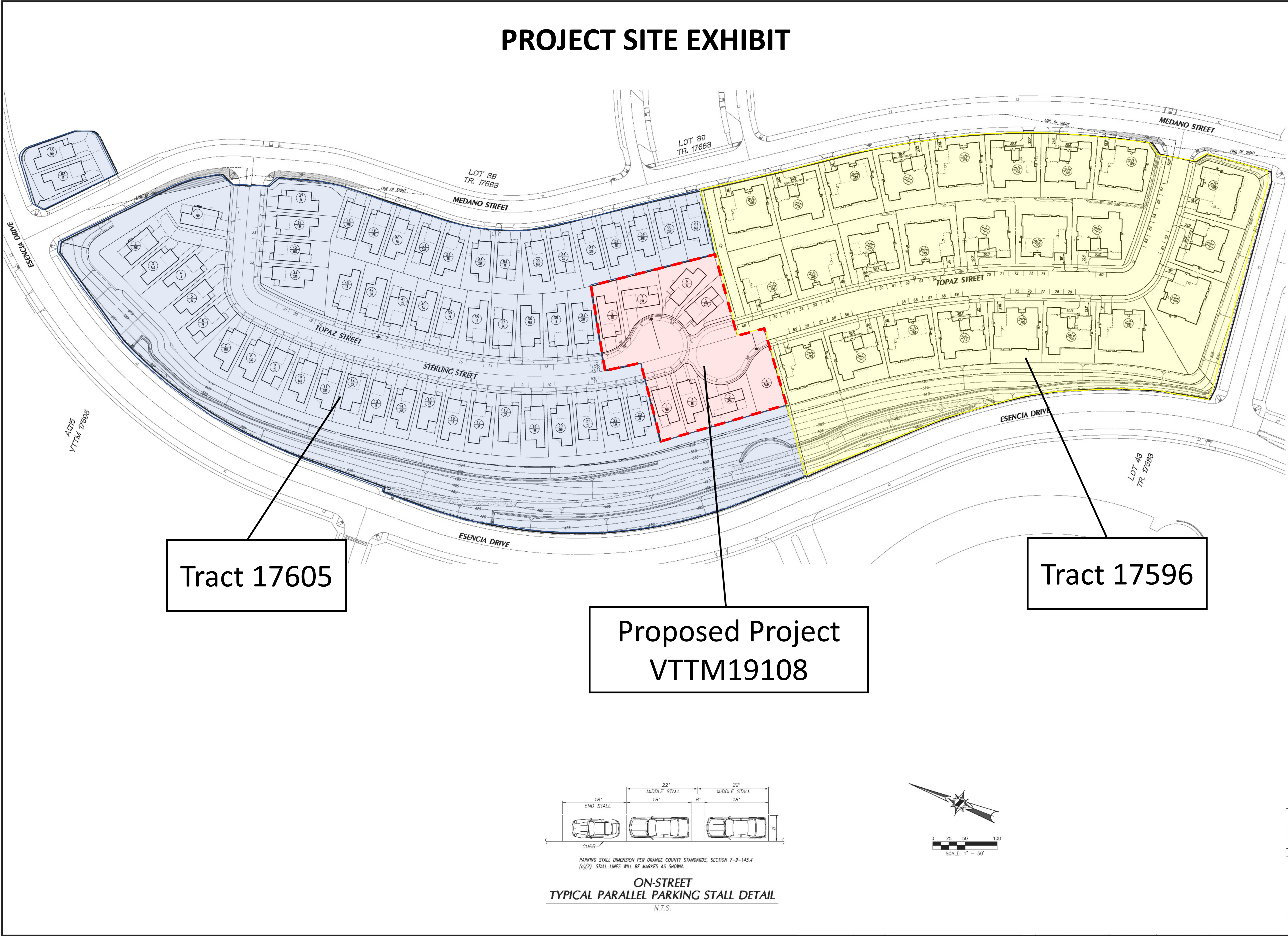

Tract 17605

Proposed Project
VTTM19108

Tract 17596

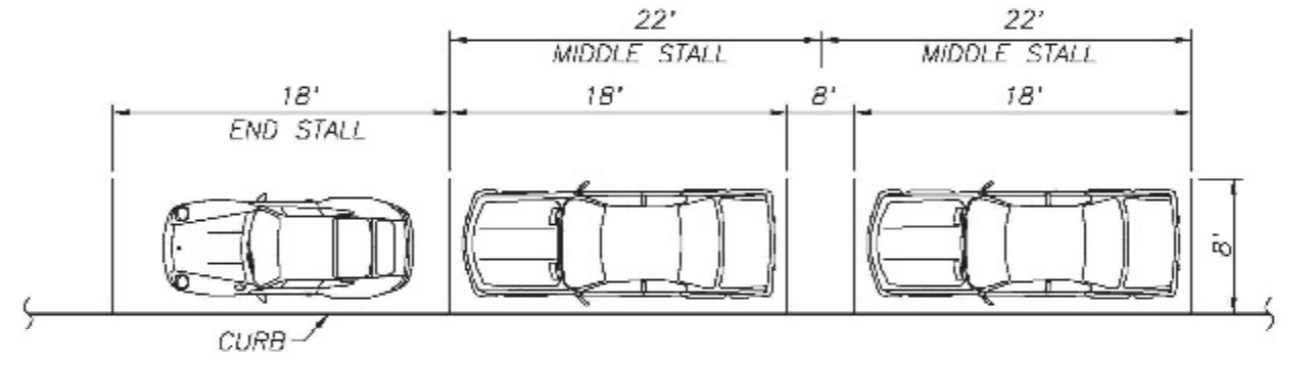

PARKING STALL DIMENSION PER ORANGE COUNTY STANDARDS, SECTION 7-9-145.4
(2X2) STALL LINES WILL BE MARKED AS SHOWN.
**ON-STREET
TYPICAL PARALLEL PARKING STALL DETAIL**
N.T.S.

ATTACHMENT 3

BOARD OF DIRECTORS

BETTY H. OLSON, PH.D. FRANK URY
CHARLES T. GIBSON SAUNDRA F. JACOBS
JUSTIN MCCUSKER

DANIEL R. FERONS
GENERAL MANAGER



Santa Margarita Water District

May 29, 2020

County of Orange
OC Public Works
OC Planning
300 N. Flower Street
Santa Ana, California 92703

Subject: Preliminary Water and Sewer Letter for The New Home Company, VTTM 19108 (Portion of 17605 in Tract 17596) Lots 1-8, Rancho Mission Viejo, in Improvement District No. 4C

Greetings:

This letter is in response to a request by The New Home Company (Developer) for a preliminary water and sewer letter for the subject tract.

The Santa Margarita Water District (District) supplies all of its current customers with domestic water purchased from the Metropolitan Water District of Southern California (Metropolitan) through the Municipal Water District of Orange County (MWDOC), which acts as a wholesaler to its member agencies. It is anticipated the subject tract would also be supplied with available domestic water purchased from Metropolitan through MWDOC. Supplemental water for this development, if required, will be provided via the implementation of an agreement between SMWD and Cucamonga County Water District (now called Cucamonga Valley Water District) that has been executed for the specific purpose of providing supplemental water in support of the "Ranch Plan". Subject to the Developer's successful completion of the construction of the in-tract water facilities, the District can and will provide domestic and non-domestic water service to each and every building parcel in the subject tract.

Furthermore, and subject to the Developer's successful completion of the in-tract sewer facilities and the District's construction of off-site sewer facilities, the District can and will provide sewer service to each and every building lot within the subject tract without exception.

At this time, the Developer has not provided surety to guarantee the construction of the in-tract water and sewer facilities. A final will-serve will be issued upon your request when (1) the Developer has guaranteed the construction of the in-tract facilities and (2) construction of the District's water and sewer facilities is assured.

Should you have any questions or desire additional information, please call Karla Houlihan at (949) 459-6581.

Sincerely,

SANTA MARGARITA WATER DISTRICT

A handwritten signature in blue ink that reads "Patricia A. Butler".

Patricia A Butler
Chief Engineer

S:\ENGINEERING\PRELIMINARY WILL SERVE\2019\Will Serve VTTM 19108 (17605 formerly portion of 17596) – The New Home Company.doc

ATTACHMENT I

VESTING TENTATIVE TRACT NO. 19108

LEGAL DESCRIPTION

LOTS 24 THROUGH 33, INCLUSIVE, IN THE UNINCORPORATED TERRITORY OF THE COUNTY OF ORANGE, STATE OF CALIFORNIA, AS SHOWN ON TRACT NO. 17805, FILED IN BOOK 986, PAGES 30 THROUGH 33, INCLUSIVE, OF MISCELLANEOUS MAPS IN THE OFFICE OF THE COUNTY RECORDER OF SAID COUNTY.

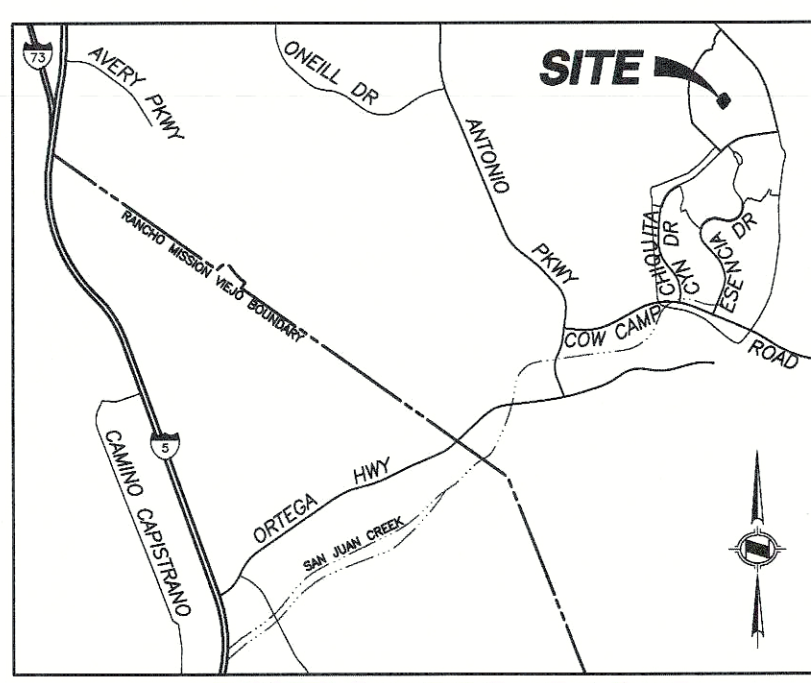

VICINITY MAP
NOT TO SCALE

REVIEWED FOR CODE COMPLIANCE

THESE PLANS AND DOCUMENTS HAVE BEEN REVIEWED AND FOUND TO BE IN COMPLIANCE WITH THE APPLICABLE JURISDICTION CODE REQUIREMENTS. ISSUANCE OF A PERMIT IS RECOMMENDED SUBJECT TO APPROVAL BY OTHER DEPARTMENTS AND ANY NOTED CONDITIONS. THIS APPROVAL DOES NOT RELIEVE THE ENGINEER OF RECORD OF THEIR RESPONSIBILITY TO PREPARE THE PLANS, SPECIFICATIONS, MAPS, AND OTHER RECORD DOCUMENTS PER CURRENT CODES AND APPLICABLE STANDARDS OF PRACTICE.

TAIT & ASSOCIATES INC.

Signature: *[Signature]* Date: 06/24/2020

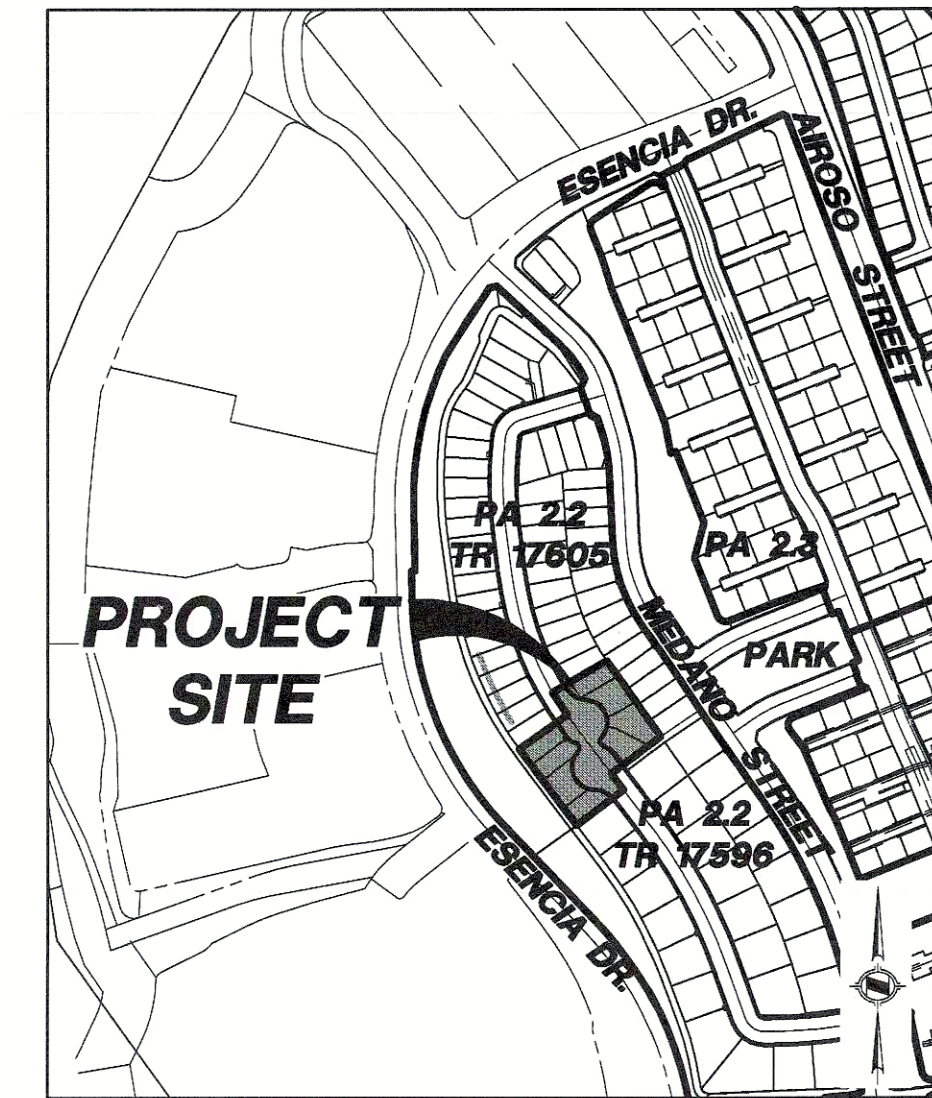

LOCATION MAP
NOT TO SCALE

NOTES

- EXISTING LAND USE: VACANT LAND. (GRADED PER GRADING PERMIT NUMBER GA 150006)
- PROPOSED LAND USE: RESIDENTIAL - 7 SINGLE FAMILY UNITS AND 1 LOT FOR POCKET PARK/OPEN SPACE.
- THE PLANNING AREA 2 MASTER AREA PLAN (PA130006) AND SUBAREA PLAN 2.3 (PA130003) DESIGNATE THE EXISTING ZONING. THIS MAP IS LOCATED WITHIN RANCH PLAN PLANNED COMMUNITY PLANNING AREA 2.3 AND IS ZONED AS A DEVELOPMENT AREA BY THE RANCH PLAN PC TEXT.
- THE PLANNING AREA 2 MASTER AREA PLAN (PA130006) AND SUBAREA PLAN 2.3 (PA130003) DESIGNATE THE PROJECT SITE AS RESIDENTIAL. THIS VESTING TENTATIVE TRACT MAP MORE SPECIFICALLY IDENTIFIES THIS SITE DESIGNATION AS CONVENTIONAL SINGLE-FAMILY DETACHED DWELLINGS, PER PC TEXT SECTION III.A.1, CONSISTENT WITH THE REFERENCED RANCH PLAN PC TEXT SITE DEVELOPMENT STANDARDS.
- ADJACENT LAND USE ZONING:

NORTH	RESIDENTIAL	RANCH PLAN PLANNED COMMUNITY
SOUTH	RESIDENTIAL	RANCH PLAN PLANNED COMMUNITY
EAST	RESIDENTIAL	RANCH PLAN PLANNED COMMUNITY
WEST	RESIDENTIAL	RANCH PLAN PLANNED COMMUNITY
- SANITARY SEWER SERVICES PROVIDED BY: SANTA MARGARITA WATER DISTRICT.
- DOMESTIC WATER SERVICE PROVIDED BY: SANTA MARGARITA WATER DISTRICT.
- NON-DOMESTIC RECYCLED WATER SERVICE PROVIDED BY: SANTA MARGARITA RANCH WATER DISTRICT.
- ALL PROPOSED UTILITIES ARE TO BE UNDERGROUND. PROPOSED UTILITY LOCATIONS SHOWN ON THE MAP ARE APPROXIMATE. ACTUAL LOCATIONS AND EASEMENT WIDTHS WILL BE REFLECTED ON FINAL TRACT MAP(S).
 - GAS: SOUTHERN CALIFORNIA GAS COMPANY
 - ELECTRIC: SAN DIEGO GAS AND ELECTRIC
 - TELEPHONE: AT&T AND COX COMMUNICATIONS
 - CABLE TELEVISION: COX COMMUNICATIONS
- PROJECT SITE IS WITHIN THE CAPISTRANO UNIFIED SCHOOL DISTRICT.
- ALL PROPOSED STORM DRAINS SHOWN HEREON ARE PRELIMINARY. STORM DRAIN PLANS WILL BE PREPARED PRIOR TO RECORDATION OF THE FINAL MAP.
- EASEMENTS
 - PUBLIC EASEMENTS (IF NECESSARY) FOR SIDEWALK PURPOSES WILL BE REFLECTED ON THE FINAL MAPS.
- THE APPLICANT REQUESTS THE OPTION OF RECORDING MULTIPLE FINAL MAPS FOR THIS VESTING TENTATIVE TRACT MAP PER SECTION 66456.1 OF THE STATE OF CALIFORNIA GOVERNMENT CODE (SUBDIVISION MAP ACT), AS AMENDED JANUARY 2017.
- STREET CENTERLINE RATES OF GRADE WILL BE BETWEEN 1% AND 10% UNLESS SHOWN OTHERWISE.
- VTTM 19108 IS NOT LOCATED WITHIN A SPECIAL FLOOD HAZARD ZONE PER THE CONDITIONAL LETTER OF MAP REVISION (CLMR) APPROVED BY FEMA AND THE COUNTY OF ORANGE IN 2007.
- ALL PROPOSED STREETS ARE TO BE PUBLIC STREETS.
- PER THE RANCH PLAN PLANNED COMMUNITY-WIDE ALTERNATIVE DEVELOPMENT STANDARDS (APPROVED MAPS 14, 2007 AND MOST RECENTLY AMENDED MAY 27, 2015; SUBSEQUENT REVISIONS OR ADDITIONS MAY ALSO BE APPROVED), AND AS ALLOWED BY RANCH PLAN PC TEXT (GENERAL REGULATION 2B) THE FOLLOWING ALTERNATIVE DEVELOPMENT STANDARDS (ADS) ARE PROPOSED.
 - A-20 ALTERNATIVE NEIGHBORHOOD SIDEWALK DETAIL CURB-SEPARATED WALKWAY
 - D-11 SINGLE FAMILY DETACHED ON-STREET PARKING
- GRADING:
 - GRADING PLANS MAY BE PROCESSED CONCURRENTLY WITH A TENTATIVE TRACT MAP. PER A CONCURRENT PROCESSING REQUEST LETTER. PLAN CHECKING OF GA OR GB PLANS MAY PROCEED, BUT APPROVAL OF THE GRADING PLAN MUST FOLLOW VTTM APPROVAL.
 - ESTIMATED EARTHWORK - PROPOSED GRADING IS CONSISTENT WITH THE PA2 MASTER AREA PLAN (PA130006) AND SUBAREA PLAN 2.3 (PA130003), VTTM 17563 AND RELATED GRADING PERMITS.
 - ENVIRONMENTAL - PROPOSED GRADING HAS BEEN ADDRESSED PER FINAL PROGRAM EIR 589 AND ADDENDUMS 1.0, 1.1 AND PLANNING AREA 2 ADDENDUM.
- IN THE DESIGN OF THIS MAP, THE SOLAR ACCESS GUIDELINES ADOPTED BY THE BOARD OF SUPERVISORS WERE CONSIDERED.
- THE EXPIRATION DATE OF THIS TENTATIVE MAP SHALL RUN CONCURRENT WITH (AND NOT TERMINATE PRIOR TO THE EXPIRATION OF) THE DEVELOPMENT AGREEMENT, EVEN IF THAT TIME FRAME EXCEEDS TEN YEARS, BASED ON GOVERNMENT CODE SECTION 66452.6.(a)(1) AND RANCH MISSION VIEJO DEVELOPMENT AGREEMENT 04-01 SECTIONS 1.2.13 AND 4.2(C).
- ALL PROPOSED SEWER AND WATER SHALL BE DEDICATED TO SANTA MARGARITA WATER DISTRICT AS PUBLIC UTILITIES.
- ALL UNITS TO BE SPRINKLERED PER RANCH FIRE PROTECTION PROGRAM AND OCA REQUIREMENTS.
- ALL INFRASTRUCTURE IMPROVEMENTS WITHIN THIS TENTATIVE TRACT MAP ARE PROVIDED BY BUILDER.
- ALL CONNECTIONS TO PUBLIC ROADWAYS WILL REQUIRE A PUBLIC PROPERTY PERMIT.
- THE NOTES, DEVIATIONS AND ALTERNATIVE DEVELOPMENT STANDARDS STATED ON VESTING TENTATIVE MAP NO. 17563-2 ARE INCLUDED IN THIS MAP BY REFERENCE.
- COUNTY PROCESSING STEPS AND PROCEDURES FOR THIS VESTING TENTATIVE TRACT MAP ARE MADE IN ACCORDANCE WITH THE RANCH PLAN SUBDIVISION FLOWCHART AND CHECKLIST AVAILABLE ON-LINE.
- DRAINAGE SYSTEM WILL BE DEVELOPED IN ACCORDANCE WITH THE O.C. PUBLIC WORKS LOCAL DRAINAGE MANUAL AND COUNTY OF ORANGE FLOOD CONTROL DISTRICT STANDARDS IN ACCORDANCE WITH THE APPLICABLE "MASTER PLAN OF DRAINAGE" (S1160002 FOR VTTM 17563R2 AND VTTM 17564R1) AND THE RUNOFF MANAGEMENT PLAN (ROMP).
- STREET IMPROVEMENTS SHOWN HEREON SHALL MEET THE REQUIREMENTS OF THE COUNTY OF ORANGE AND THE RANCH PLAN ALTERNATIVE DEVELOPMENT STANDARDS.
- ALL SLOPES SHALL BE CONSTRUCTED AT A MAXIMUM SLOPE RATIO OF 2:1.
- FLOW TRIBUTARIES TO THE SITE SHALL BE INTERCEPTED AND CONVEYED AROUND AND THROUGH THE SITE VIA THE PROPOSED STORM DRAIN SYSTEMS SHOWN HEREON.
- ACCESS TO THE SITE IS PROPOSED VIA TOPAZ STREET AND STERLING STREET (PUBLIC).
- THIS MAP IS AN APPLICATION FOR A DEVELOPMENT PERMIT PURSUANT TO SECTION 65943 OF THE CALIFORNIA GOVERNMENT CODE.
- PROPOSED UTILITIES AND EASEMENTS, INCLUDING BUT NOT LIMITED TO PUBLIC UTILITIES, FIRE ACCESS, PRIVATE ACCESS, PRIVATE UTILITIES AND ACCESS ARE APPROXIMATE. ACTUAL UTILITY AND TRAIL LOCATIONS AND EASEMENT WIDTHS WILL BE REFLECTED ON THE FINAL MAPS, OR BY SEPARATE EASEMENT DOCUMENTS SUBSEQUENT TO FINAL MAP RECORDATION.
- ALL PROPOSED STORM DRAIN IMPROVEMENTS ARE TO BE PUBLIC.
- LOT 4 SHALL BE DEVELOPED EXCLUSIVELY AS A POCKET PARK/OPEN SPACE AND REQUIRE A SITE DEVELOPMENT PERMIT TO DO SO. LOT 4 SHALL NOT BE DEVELOPED AS A RESIDENTIAL LOT.
- ALL EXISTING EASEMENT AND IRREVOCABLE OFFERS OF DEDICATION THAT AFFECT THE PROPERTY BEING SUBDIVIDED ARE SHOWN ON THE TENTATIVE MAP, INCLUDING LOCATIONS, PURPOSE AND WIDTH.
- PROPOSED STORM DRAIN SYSTEM IS DESIGNED TO HANDLE THE OFFSITE STORM WATER FROM TRACT 17596 FLOWING IN TOPAZ STREET, SEE HYDROLOGY AND HYDRAULICS STUDIES FOR DRAINAGE STUDY OF THE SITE.

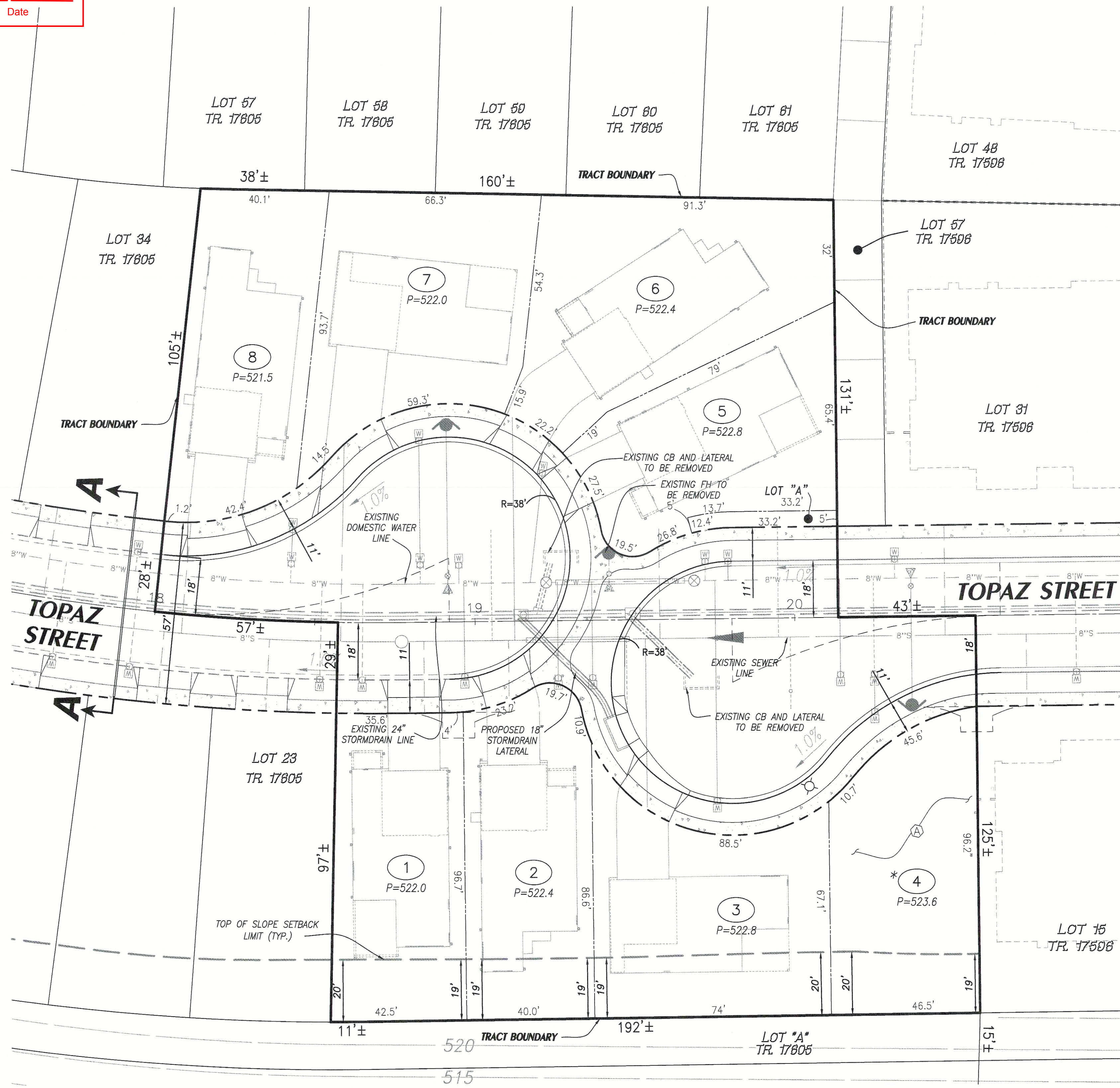

ALL LOTS AND SLOPES REMAIN GRADED PER APPROVED ROUGH GRADE (GA 150006) AND APPROVED PRECISE GRADING PLAN (GRD 19-0087)

LEGEND

- PROJECT BOUNDARY
- LOT LINE
- PROPOSED CENTERLINE
- PROPOSED CONTOUR LINE
- RIGHT OF WAY
- TOP OF SLOPE
- TOE OF SLOPE
- PROPOSED EASEMENT
- STREET CURB
- PROPOSED RETAINING WALL
- MASS GRADED CONTOUR
- STORM DRAIN
- DOMESTIC WATER
- SEWER
- TOP OF SLOPE SETBACK LIMIT
- PROPOSED FIRE HYDRANT
- P= PAD ELEVATION
- EXISTING FENCE WALL (PER SEPARATE PLAN)

NUMBERED LOTS SUMMARY

LOT NUMBER	LOT SIZE S.F.	LOT SIZE ACRES
1	3,973	0.09
2	4,021	0.09
3	4,671	0.11
4	3,985	0.09
5	4,025	0.09
6	5,416	0.12
7	4,779	0.11
8	4,086	0.09
TOTAL	34,956	0.80

*LOT INTENDED ONLY FOR PARK/OPEN SPACE PURPOSES

LETTERED LOTS SUMMARY

LOT	LOT SIZE S.F.	LOT SIZE ACRES	USE
A	231	0.01	LANDSCAPE
TOTAL	231	0.01	

ACREAGE SUMMARY

DESCRIPTION	ACRES
TOTAL NUMBERED LOTS	0.80
TOTAL LETTERED LOTS	0.01
PUBLIC STREET	0.40
TOTAL PROJECT ACREAGE	1.21

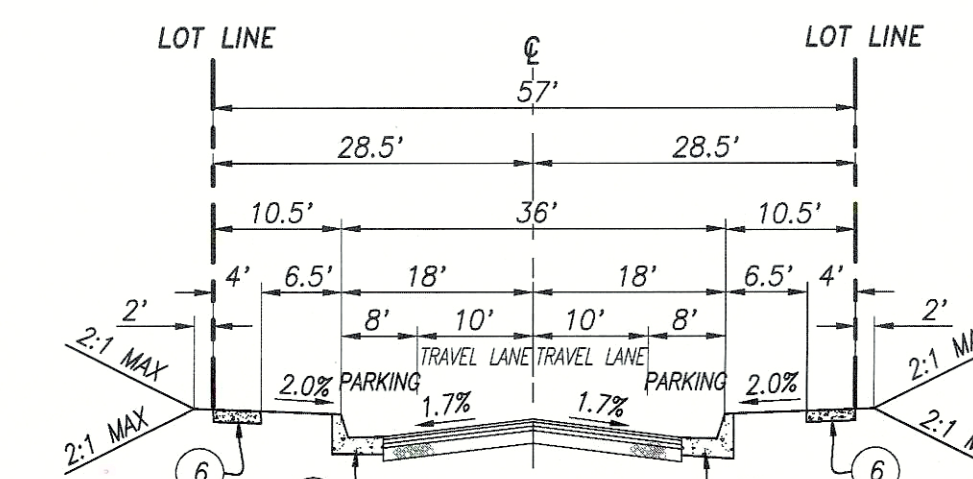

SECTION A-A
"TOPAZ STREET"
EXISTING INTERIOR STREET PUBLIC

*A MINIMUM OF A 5'X5' ADA PASSING ZONE SHOULD BE PROVIDED AT A MAXIMUM INTERVAL OF 200' FOR SIDEWALKS LESS THAN 5' IN WIDTH

STATEMENT OF OWNERSHIP

THE NEW HOME COMPANY SOUTHERN CALIFORNIA, LLC IS THE OWNER OF PORTION OF PA2 COVERED BY TRACT NO. 19108 AND AUTHORIZED TO EXECUTE AND DELIVER ALL DOCUMENTS THAT ARE NECESSARY AND APPROPRIATE FOR PROCESSING AND IMPLEMENTING THE PA2 DEVELOPMENT PROGRAM. SAID AUTHORIZATION INCLUDES, BUT IS NOT LIMITED TO THE EXECUTION AND DELIVERY OF SUCH APPLICATIONS, AGREEMENTS AND OTHER DOCUMENTS AS ARE REQUIRED BY THE COUNTY OF ORANGE IN CONNECTION WITH THE PROCESSING AND DEVELOPMENT OF PA2.

DATED THIS 19TH DAY OF JUNE, 2020
 BY: *[Signature]*
 PRINTED NAME: ANDREW J. JARVIS
 TITLE: PRESIDENT

STATEMENT OF OWNERSHIP

RMV PA2 DEVELOPMENT, LLC IS THE OWNER OF PORTION OF PA2 COVERED BY TRACT NO. 19108 AND AUTHORIZED TO EXECUTE AND DELIVER ALL DOCUMENTS THAT ARE NECESSARY AND APPROPRIATE FOR PROCESSING AND IMPLEMENTING THE PA2 DEVELOPMENT PROGRAM. SAID AUTHORIZATION INCLUDES, BUT IS NOT LIMITED TO THE EXECUTION AND DELIVERY OF SUCH APPLICATIONS, AGREEMENTS AND OTHER DOCUMENTS AS ARE REQUIRED BY THE COUNTY OF ORANGE IN CONNECTION WITH THE PROCESSING AND DEVELOPMENT OF PA2.

DATED THIS 23RD DAY OF JUNE, 2020
 BY: *[Signature]*
 PRINTED NAME: PAUL JOHNSON
 TITLE: EXP - COMMUNITY DEVELOPMENT

ENGINEER'S STATEMENT

I HEREBY STATE THAT THIS MAP WAS PREPARED UNDER MY SUPERVISION AND THAT THE OWNER OF RECORD HAS KNOWLEDGE OF AND CONSENTS TO THE FILING OF THIS MAP.

[Signature] DATE 6/19/20

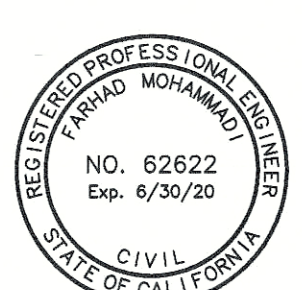

DATE	REVISION DESCRIPTION

UTILITY PROVIDERS

- | | |
|-----------------------------|-----------------------------|
| SANITARY SEWER | SANTA MARGARITA DISTRICT |
| DOMESTIC WATER | SANTA MARGARITA DISTRICT |
| NON-DOMESTIC RECYCLED WATER | SANTA MARGARITA DISTRICT |
| GAS | SOUTHERN CALIFORNIA COMPANY |
| ELECTRIC | SAN DIEGO GAS AND ELECTRIC |
| TELEPHONE | AT&T AND COX COMMUNICATIONS |
| CABLE TELEVISION | COX COMMUNICATIONS |

SLOPE DESIGNATIONS

ALL MANUFACTURED SLOPES TO HAVE TERRACE AND DOWN DRAINS AS REQUIRED BY THE COUNTY OF ORANGE GRADING CODE REQUIREMENTS.
 (A) MAINTAINED BY THE HOA

REFERENCE NUMBERS

- TENTATIVE TRACT MAP 17596
- TENTATIVE TRACT MAP 17805
- GA 150006 ROUGH GRADE
- GRD 19-0087 PRODUCTION PRECISE GRADING
- ST 170006 STREETS & STORM DRAIN
- PA 170015 SITE DEVELOPMENT
- GB 170041 PRODUCTION PRECISE GRADING
- STP 19-0004 STREET & STORM DRAIN

APPLICANT: **NEW HOME COMPANY** | **TNHc SoCal, LLC**
 85 ENTERPRISE, SUITE 450
 ALISO VIEJO, CA 92656
 TEL: 949-982-7829 FAX: 949-982-7801

PREPARED BY: **HUNSAKER & ASSOCIATES**
 IRVINE, INC.
 PLANNING • ENGINEERING • SURVEYING
 Three Hughes • Irvine, CA 92618 • P: (949) 583-1070 • F: (949) 583-0759

COUNTY OF ORANGE

VESTING TENTATIVE TRACT NO. 19108
RANCH PLAN - PLANNING SUBAREA 2.3

DESIGNED BY: --- DATE: 6/8/2020 CITY FILE NO.: --- SHEET **C-1**

DRAFTED BY: --- CHECKED BY: ---

FIRE MASTER PLAN

MR-29

RANCHO MISSION VIEJO - PLANNING AREA 2.3

TRACT NO. 17605, LOTS 1-23, 34-63 & TRACT 19108 LOTS 1-8,

RANCHO MISSION VIEJO - COUNTY OF ORANGE

OCFA REVISION S.R. NO. 288348

PREVIOUS APPROVED OCFA REVISION S.R. NOS. 286423, 279377 & 276658

PARKING ENFORCEMENT LETTER

May 4, 2020

Planning and Development Services Section
Orange County Fire Authority
1 Fire Authority Road
Irvine, CA 92602

Re: Rancho Mission Viejo, Planning Area P2.3, MR-29, Tract 17605, Lots 1-23, 34-63 & Tract 19108, Lots 1-8, Rancho Mission Viejo, County of Orange, CA.
OCFA Service Request Number 288348 Parking Enforcement Plan

The fire lane parking enforcement plan for the above referenced project is stated as follows:

All fire lanes within MR-29 shall be maintained and in no event shall parking be permitted along any portion of a street or drive that required fire lanes or any area designated as a fire lane for turn-around or drive through purposes.

MR-29 Homeowner's Association shall adopt reasonable rules and regulations regarding the parking of vehicles along the streets, roads and or drives within the project that are not in conflict with applicable law.

In furtherance thereof, MR-29 Homeowner's Association, through its officers, committees and agents will establish the "parking" and "no parking" areas within the property in accordance with Section 22658.2 of the California Vehicle Code and the Ranch Fire Protection Program. The law shall be enforced through such rules and regulations by all lawful means, including, written warnings, citing, towing and impounding vehicles in violation.

MR-29 Homeowner's Association will contract with a certified patrol and towing company to remove vehicles that violate no parking restrictions. First time violators will receive a written warning and with subsequent violations, the vehicle shall be subject to towing. The vehicle owner shall be responsible for all costs incurred in remedying such violation, including without limitation towing cost, citations and legal fees.

COMBUSTIBLE CONSTRUCTION LETTER

May 4, 2020

Planning and Development Services Section
Orange County Fire Authority
1 Fire Authority Road
Irvine, CA 92602

Subject: Combustible Construction Letter OCFA Service Request Number 288348, Rancho Mission Viejo, Planning Area 2.3, MR-29, Tract 17605, Lots 1-23, 34-63 & Tract 19108, Lots 1-8 Rancho Mission Viejo, County of Orange, CA.

The purpose of this letter is to notify you that Tract 17605, 1-23, 34-63 & Tract 19108, Lots 1-8, shall install all required paved fire access roads that meet OCFA access requirements per the approved plans. All fire hydrants and water supply for firefighting purposes shall be installed per the approved plans and shall meet all fire flows requirements, prior to any combustible construction materials being delivered for construction.

PROJECT LOCATION WITHIN PLANNING AREA 2.3

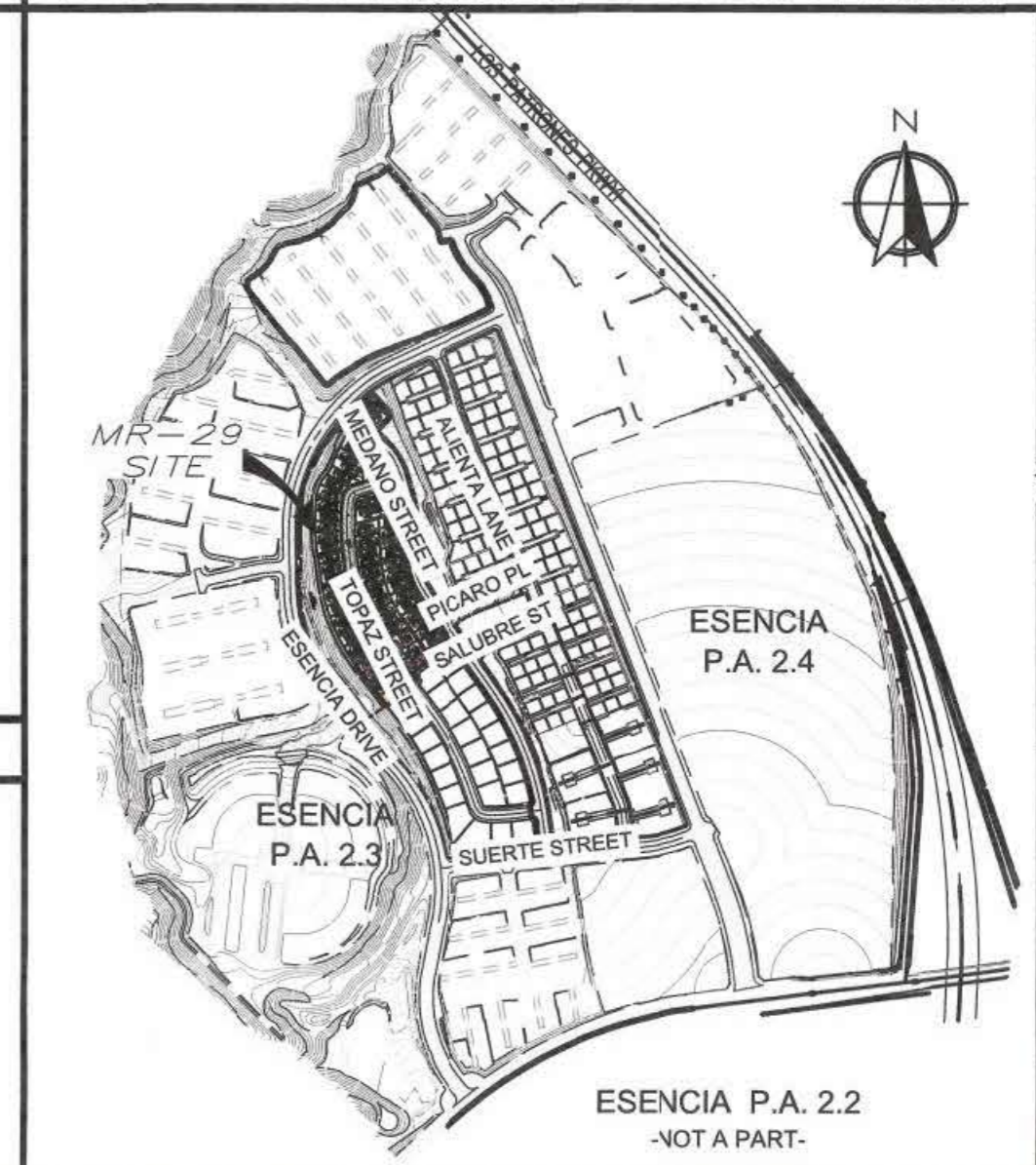

VICINITY MAP

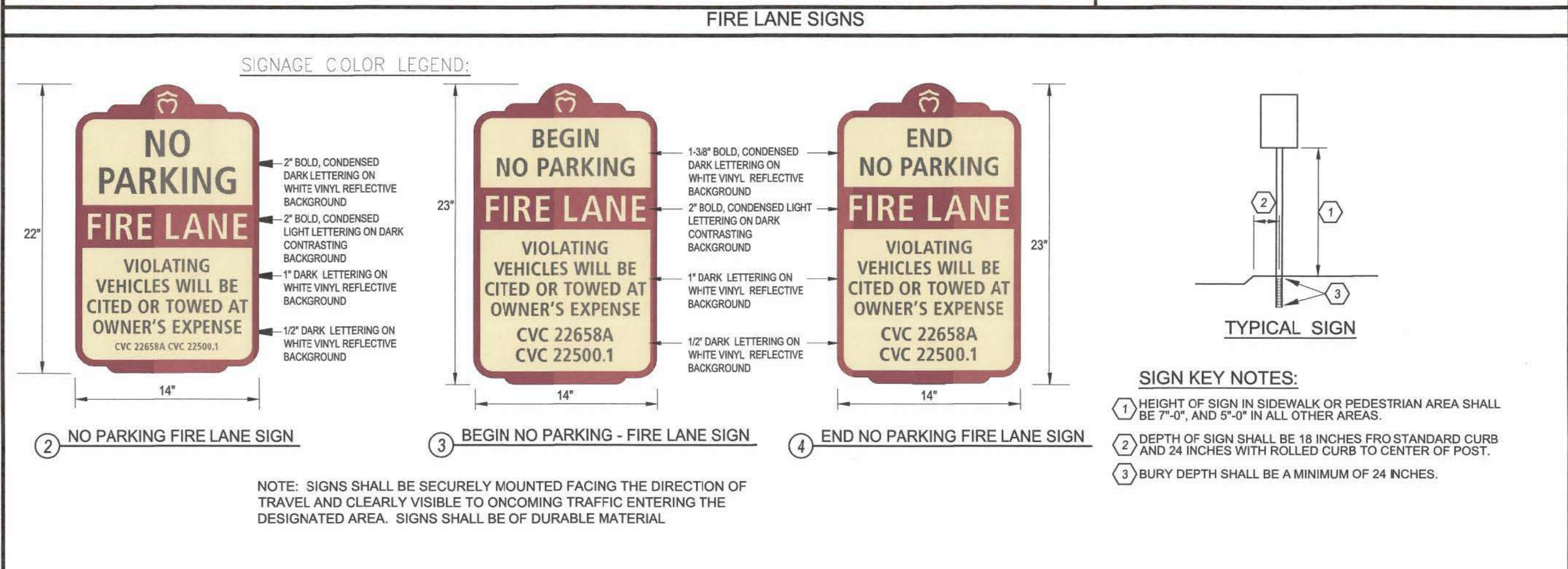
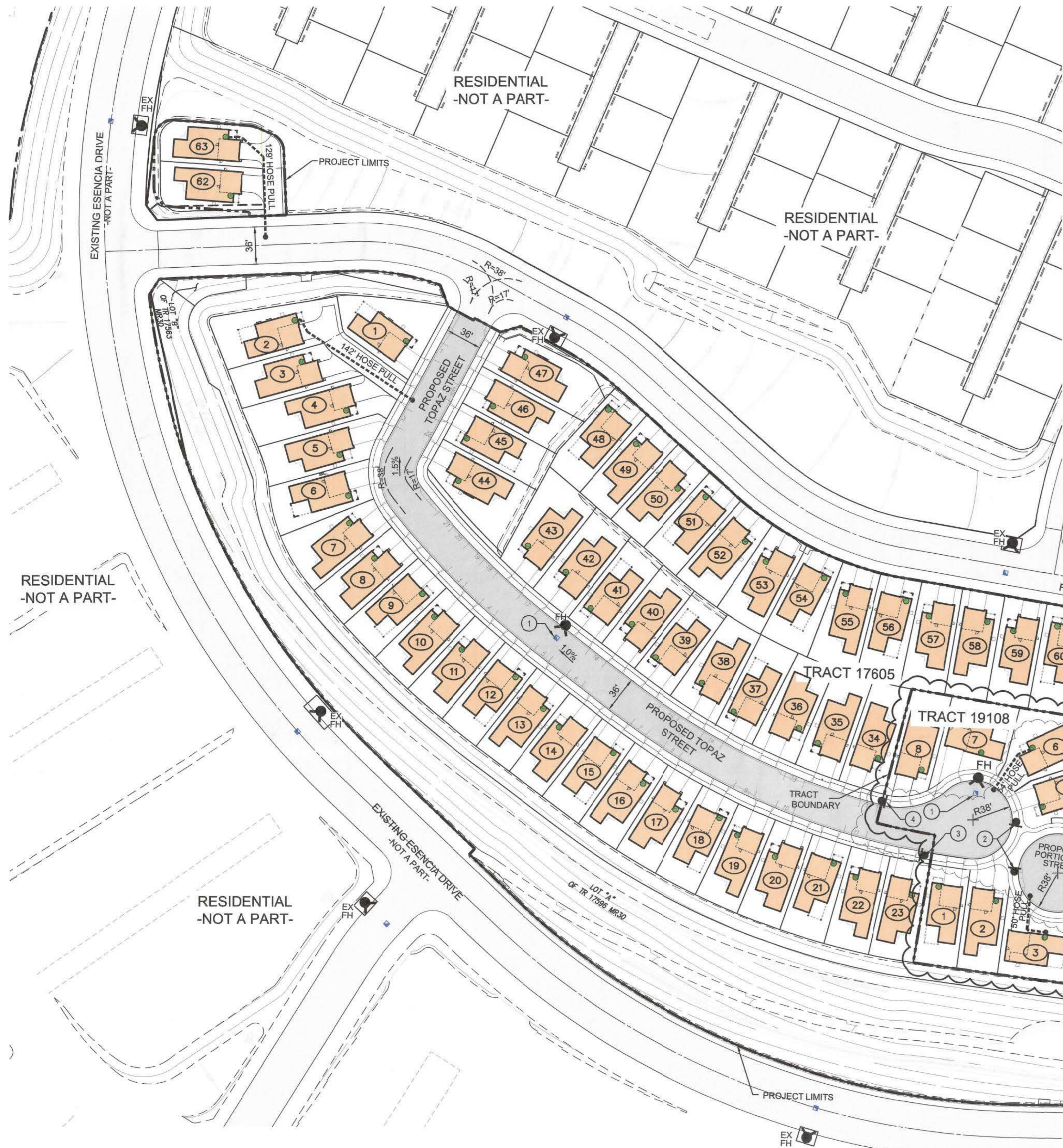
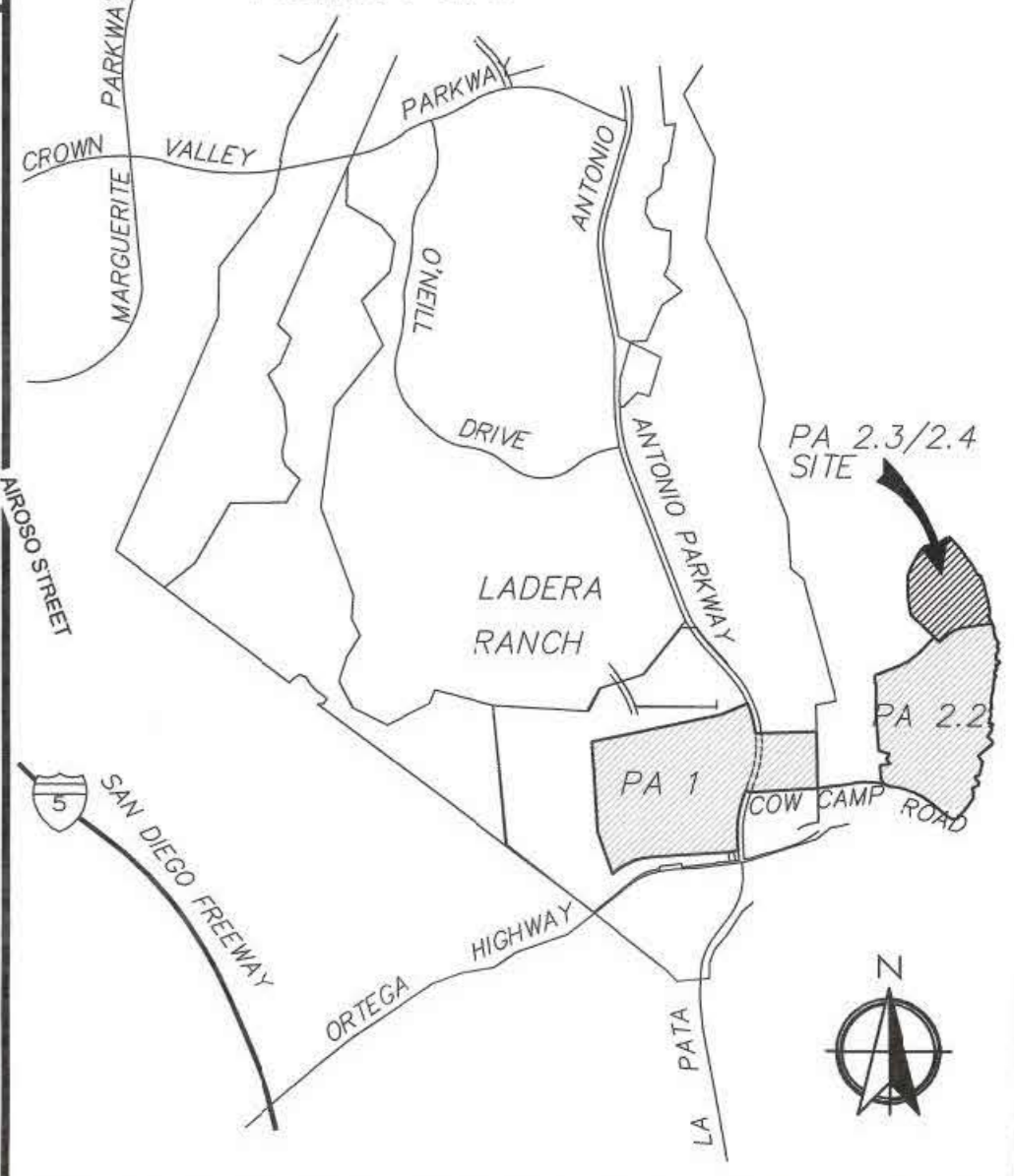

OCFA FIRE MASTER PLAN NOTES

- INSPECTION REQUIREMENTS**
- OCFA site inspections are required for this project. Please schedule all field inspections at least 48 hours in advance. Inspections canceled after 1 p.m. on the day before the scheduled date will be subject to a re-inspection fee. Call OCFA Inspection Scheduling at (714) 573-6150.
 - A lumber drop inspection shall be performed prior to bringing combustible materials (or combustible fixtures and finishes for structures of non-combustible construction). All-weather access roads capable of supporting 68,000 lbs., topped with asphalt, concrete, or equivalent shall be in place and hydrants operational at time of lumber drop inspection.
 - For projects with fuel modification, a vegetation clearance inspection is required prior to a lumber drop inspection. Use the fuel modification plan service request number to schedule the vegetation clearance inspection.
 - Phased installation of fire access roads requires additional inspections not covered by the fees paid at plan submittal. Contact Inspection Scheduling to arrange for additional inspections that may be needed and any fees that may be due.
 - An original approved, signed, wet-stamped OCFA fire master plan shall be available on-site at time of inspection.
 - Access roads and hydrants shall be maintained and remain clear of obstructions at all times during and after construction. Areas where parking is not permitted shall be clearly identified at all times. Obstruction of fire lanes and hydrants may result in cancellation or suspension of inspections.
 - Temporary fuel tanks of 60 or more gallons shall be reviewed, inspected, and permitted by the OCFA prior to use.
 - The project address shall be clearly posted and visible from the public road during construction.
 - All gates in construction fencing shall be equipped with either a Knox or breakaway postlock.
 - Buildings of four or more stories shall be provided with stairs and a standpipe before reaching 40 feet in height.
- GENERAL REQUIREMENTS**
- Fire lane widths shall be measured from top face of the curb to top face of the curb for fire lanes with standard curbs and gutters and from flow-line to flow-line for fire lanes with modified curb designs (e.g., rolled, ramped, etc.). The developer is responsible to verify that all approved public works or grading department street improvement plans or precise grading plans conform to the minimum street width measurements per the approved OCFA fire master plan and standards identified in the Ranch Plan Fire Protection Program (RPFPP) for all portions of the fire access roads.
 - Permanent, temporary, and phased emergency access roads shall be designed and maintained to support an imposed load of 68,000 lbs. and surfaced to provide all-weather driving capabilities.
 - Fire lane signs and red curbs shall meet the specifications shown in RPFPP and shall be installed as described therein. Additional fire lane markings may be required at the time of inspection depending on field conditions.
 - All fire hydrants shall have a "Blue Reflective Pavement Marker" indicating their location per the RPFPP. On private property markers are to be maintained in good condition by the property owner.
 - Address numbers shall be located and be of a color and size so as to be plainly visible and legible from the roadway from which the building is addressed in accordance with RPFPP. Wayfinding signs, when required by the local A.H.J. shall comply with the standards of that agency. When wayfinding signs are also required by the RPFPP, they may be designed to local A.H.J. requirements provided that such standards facilitate location of structures, suites, and dwelling units by emergency personnel.
 - Access gates shall be approved prior to installation and shall be in compliance with Chapter 5 of the CFC and RPFPP guidelines.
 - Approved access walkways shall be provided to all required openings and all rescue windows.
 - Vegetation shall be selected and maintained in such a manner as to allow immediate access to all hydrants, valves, fire department connections, pull stations, extinguishers, sprinkler risers, alarm control panels, rescue windows, and other devices or areas used for firefighting purposes. Vegetation or building features shall not obstruct address numbers or inhibit the functioning of alarm bells, horns, or strobes.
 - Dumpsters and trash containers larger than 1.5 cubic yards shall not be stored in buildings or placed within 5 feet of combustible walls, openings or combustible roof eave lines unless protected by an approved sprinkler system.
 - Any future modification to the approved Fire Master Plan or approved site plan, including but not limited to road width, grade, speed humps, turning radii, gates or other obstructions, shall require review, inspection, and approval by the RPFPP.
 - Approval of this plan shall not be construed as approval of any information or project conditions other than those items and requirements identified in RPFPP and related portions of the 2016 CFC and CBC. This project may be subject to additional requirements not stated herein upon examination of actual site and project conditions or disclosure of additional information.
- PROJECT-SPECIFIC REQUIREMENTS**
- Structures located in a Fire Hazard Severity Zone or Wildland-Urban Interface Fire Area are subject to the construction requirements prescribed in Chapter 7A of the 2016 CBC and/or Section 337 of the 2016 CRC. Construction methods/materials are reviewed and inspected by the Building Department.
 - Projects located in State Responsibility Areas shall also comply with all applicable requirements from Title 14, Div. 1.5, Ch. 7, SubCh. 2 "SRA Fire Safe Regulations" and RPFPP.

REVISION	
NO.	DESCRIPTION
04-23-2019	THE FIRE MASTER PLAN WAS REVISED TO MATCH THE CURRENT SITE PLAN WITH AN ADDITIONAL LOT ADDED.
02-10-2020	THIS FIRE MASTER PLAN HAS BEEN REVISED TO PROVIDE CUL-DE-SACS ALONG TOPAZ STREET BASED ON ADDRESSING REQUIREMENTS. FIRE HYDRANTS HAVE BEEN PROVIDED ALONG EACH CUL-DE-SAC TO MEET MINIMUM SPACING REQUIREMENTS AND FIRE LANE NO PARKING SIGNS WITHIN THE 76' DIAMETER CUL-DE-SACS.
05-04-2020	THIS FIRE MASTER PLAN HAS BEEN REVISED TO PROVIDE NEW TRACT NO. 19108, LOTS 1-8 WHICH WAS PART OF TRACT 17605. LOTS FOR TRACT 17605 REMAINED BEEN RETAINED WITH LOTS 24 THROUGH 33 NOW BEING TRACT 19018 LOTS 1 THROUGH 8. ADDITIONALLY, THE FIRE HYDRANT ON THE NORTHERN CUL-DE-SAC HAS BEEN REPLACED IN FRONT OF LOT 7 OF TRACT 19108 DUE TO UTILITY CONFLICTS.

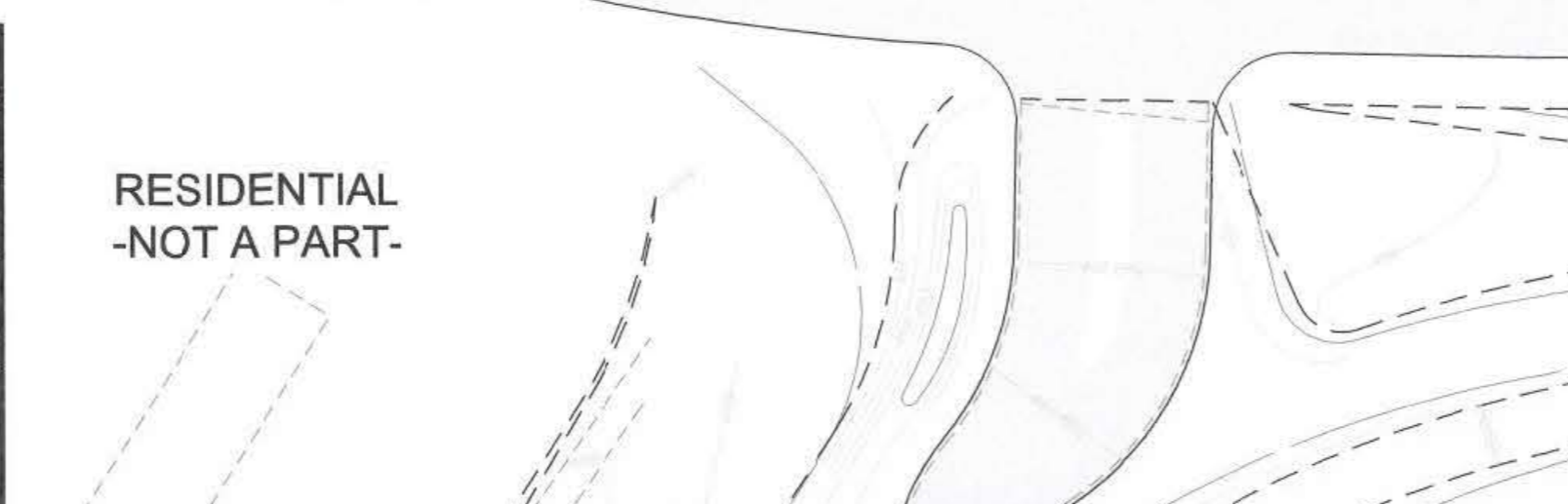
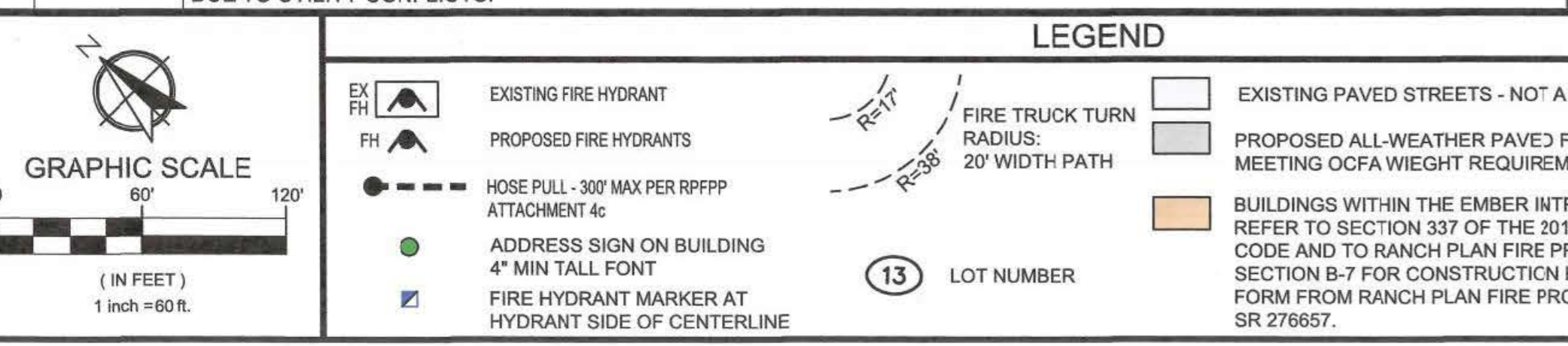

PREPARED FOR:

THE NEW HOME COMPANY
85 ENTERPRISE, SUITE 450
ALISO VIEJO, CA 92656

CIVIL ENGINEER:

HUNSAKER & ASSOCIATES
PLANNING • ENGINEERING • SURVEYING
Three Hughes
Irvine, CA 92618
PK (714) 583-0759
FX (714) 583-0710

PREPARED BY:

firesafe
PLANNING SOLUTIONS
302 N. EL CAMINO REAL, SUITE 222
SAN CLEMENTE, CA 92672
(949) 240-5911

TITLE:

FIRE MASTER PLAN
MR-29
RANCHO MISSION VIEJO
ESENCIA - PLANNING AREA 2.3
TRACT NO. 17605 - LOTS 1-23, 34-63 & TRACT NO. 19108 - LOTS 1-8
OCFA REVISION S.R. NO. 288348
PREVIOUSLY APPROVED S.R. NOS. 286423, 276658 & 279377
RANCHO MISSION VIEJO - COUNTY OF ORANGE

DATE: 05/04/20
SHEET: F-1
OF 1

ORANGE COUNTY FIRE AUTHORITY
Reviewed by Planning & Development
Services Section after 6 Months of Inactivity
This plan is void if not used and required for
re-approval. All other conditions and requirements
of these plans shall not be held to be null and void
due to the violation of any law.

OCFA SR #: 288348
Fee Codes: PR 128 / 922
Plan Type: Fire Master Plan
By: A. Guzman
Emp #: 4972 Date: 5/13/2020

ONLY STAMPED SHEETS REVIEWED BY
ORANGE COUNTY FIRE AUTHORITY
Call at least 48 hours in advance to schedule
inspections: (714) 573-6150

Notes: Revision of SR 286423

BUILDING DATA

- All buildings on plan are Type V-B and are under 6,000sq/ft.
- Required fireflow of 1,500 GPM @ 20 PSI or 2 hours.
- All Fire Sprinkler Systems shall be type NFPA-13D.

RANCH FIRE PROTECTION PROGRAM ATTACHMENTS

Ranch Plan Fire Protection Program was approved by Orange County Fire Authority and Orange County Board of Supervisors dated: July 31, 2007 and Amendment No. 1, dated: March 25, 2013 and Amendment No. 2, dated: August 14, 2014.

- Attachments used with this Submittal:
- 3b Fire Lane No Parking Sign
 - 3c Fire Lane Begin / End No Parking Sign
 - 40 300' Hose Pull to Front Door
 - 10 Hydrant Distribution Table
 - 11 Fire Flow Requirement Table
 - 12 b Blue Dot Hydrant Marker Location
 - 15 Radiant Heat and Ember Mitigation Zones