



ITEM #2

SUBDIVISION COMMITTEE PRELIMINARY REPORT

DATE: November 20, 2024

TO: Orange County Subdivision Committee

FROM: OC Development Services / Land Development Division

SUBJECT: "B" Vesting Tentative Tract Map 19306 within Planning Area 3, Subarea 3.4, Ranch Plan Planned Community

PROPOSAL: The applicant, Rancho Mission Viejo (RMV), requests approval of "B" Vesting Tentative Tract Map 19306 (VTTM19306) to subdivide a 9.78-acre site within Subarea 3.4 of the Ranch Plan Planned Community into 87 legal lots: 72 numbered lots for planned concept single-family detached dwellings, 7 lettered lots for usable project open space, 6 lettered lots for private motor courts and 2 lettered lots for slopes/landscape.

ZONING: Ranch Plan Planned Community

GENERAL PLAN: 6 "Urban Activity Center"

LOCATION: The project site is located in the southeastern portion of unincorporated Orange County, within Subarea 3.4, Lots 8 through 19 of "A" Tract Map 17934 in the Ranch Plan Planned Community. The project site is located east of Ranch Canyon and north of Cow Camp Road, at the intersection of Gavilan Ridge and Hawk Street, within the Fifth (5th) Supervisorial District.

**OWNER/
SUBDIVIDER:** RMV PA3 Development, LLC (RMV)

It is noted that the current landownership is RMV, but the transfer of ownership to Lennar Homes will begin upon recordation of the Final Tract Map.

APPLICANT: Rancho Mission Viejo
Jay Bullock, Vice President, Planning and Entitlement

STAFF CONTACT: Robert Zegarra, Contract Planner, Land Development Division
Phone: (714) 667-8893
Email: Robert.Zegarra@ocpw.ocgov.com

RECOMMENDED ACTION(S):

Land Development recommends OC Subdivision Committee:

- 1) Receive staff report and public testimony as appropriate.
- 2) Find that Final EIR 589, previously certified on November 8, 2004; Addendum 1.0 (PA060023) approved July 2006, Addendum 1.1 (PA110003-06) approved February 24, 2011, the Planning Area 2 Addendum (PA130001-06) approved March 27, 2013, and Addendum 3.1 (PA140072-81) approved February 25, 2015 reflect the independent judgment of the County and are adequate to satisfy the requirements of CEQA for approval of Vesting Tentative Tract Map (VTTM) 19306, which is a necessarily included element contemplated as part of the whole of the action considered in Final EIR 589, Addendum 1.0, Addendum 1.1, the Planning Area 2 Addendum, and Addendum 3.1.
 - a. The circumstances of the project are substantially the same as described in Final EIR 589, Addendum 1.0, Addendum 1.1, the Planning Area 2 Addendum, and Addendum 3.1, which adequately addressed the effects of the project proposed in VTTM19306. No substantial changes have been made in the project that involve new significant environmental effects or a substantial increase in the severity of previously identified significant effects; no substantial changes have occurred in the circumstances under which the project is being undertaken, that involve new significant environmental effects or a substantial increase in the severity of previously identified environmental effects; and no new information of substantial importance to the project which was not known or could not have been known when Final EIR 589, Addendum 1.0, Addendum 1.1, the Planning Area 2 Addendum, and Addendum 3.1 were certified and approved has become known; therefore, no further environmental review is required.
 - b. Final EIR 589, Addendum 1.0, Addendum 1.1, the Planning Area 2 Addendum, and Addendum 3.1, are adequate to satisfy the requirements of CEQA for VTTM19306.
 - c. All mitigation measures are fully enforceable pursuant to Public Resources Code section 21081.6(b) and have either been adopted as conditions, incorporated as part of the project design, or included in the procedures of project implementation.
- 3) Approve Vesting Tentative Tract Map 19306, subject to the attached Findings and Conditions of Approval (Appendices A and B).

BACKGROUND AND EXISTING CONDITIONS:

In November 2004, the County of Orange approved the Ranch Plan Planned Community, which encompasses approximately 22,815 acres located east of I-5, north and south of Ortega Highway at Antonio Parkway/La Pata Avenue, within the Fifth Supervisorial District. As approved, the Ranch Plan Planned Community comprises 75 percent permanent open space and allows for the development of 14,000 dwelling units and 5,200,000 square feet (SF) of non-residential uses in the remaining 25 percent. It is regulated by the Ranch Plan PC Program Text which addresses the unique characteristics of the property and a development plan for the transition to suburban uses occurring over a 25- to 30-year period.

The Master Area Plan and Subarea Plans for Planning Areas 3 and 4 were originally approved on February 25, 2015, by the Planning Commission (PA140072-PA140081) and revised administratively on May 22, 2017 (PA150047). On September 11, 2019, the Planning Commission approved amendments and revisions to the Master Area Plans and Subarea Plans for Planning Areas 3 and 4 (PA180030) which reflect the applicant's plan to develop Planning Area 3 in smaller phases. Additional administrative revisions to the Master Area Plans and Subarea Plans for Planning Areas 3 and 4 were approved on October 27, 2022 (PA22-0067), and again in October of 2024 (PA24-0104).

Subdivision Committee Report – November 20, 2024

VTTM19306 – RMV Subarea 3.4

Page 3 of 8

Final Tract Map 17934 for Subarea 3.4 was approved by the Orange County Board of Supervisors on October 22, 2024. Currently, Subarea 3.4 is being graded under permit GRD23-0059 and supporting infrastructure (streets, storm drains, etc.) is in various stages of construction.

Proposed Project

The applicant, Rancho Mission Viejo, requests approval of “B” Vesting Tentative Tract Map 19306 (VTTM19306) to subdivide a 9.78-acre site within Subarea 3.4 of the Ranch Plan Planned Community into 87 legal lots: 72 numbered lots for planned concept detached dwellings, 7 lettered lots for usable project open space, 6 lettered lots for private motor courts, and 2 lettered lots for slopes/landscape. This VTTM is one of multiple “B” maps being proposed in Planning Area 3, Subarea 3.4 of the Ranch Plan. Final Map 17934 established the boundaries of these “B” maps (Exhibit 2 page 4). Further discussion is provided in the Discussion/Analysis section.

SURROUNDING LAND USE:

Land uses immediately surrounding the project site include the following:

- North: Bucker Way, Future Subarea 3.11.
- East: Future Residential Tract 19307.
- West: Future Linear Park, Future Residential Tract 19305.
- South: Gavilan Ridge, Future Residential Tract 19309.

Please refer to General Vicinity Map (below) and the Project Site Map (following page).

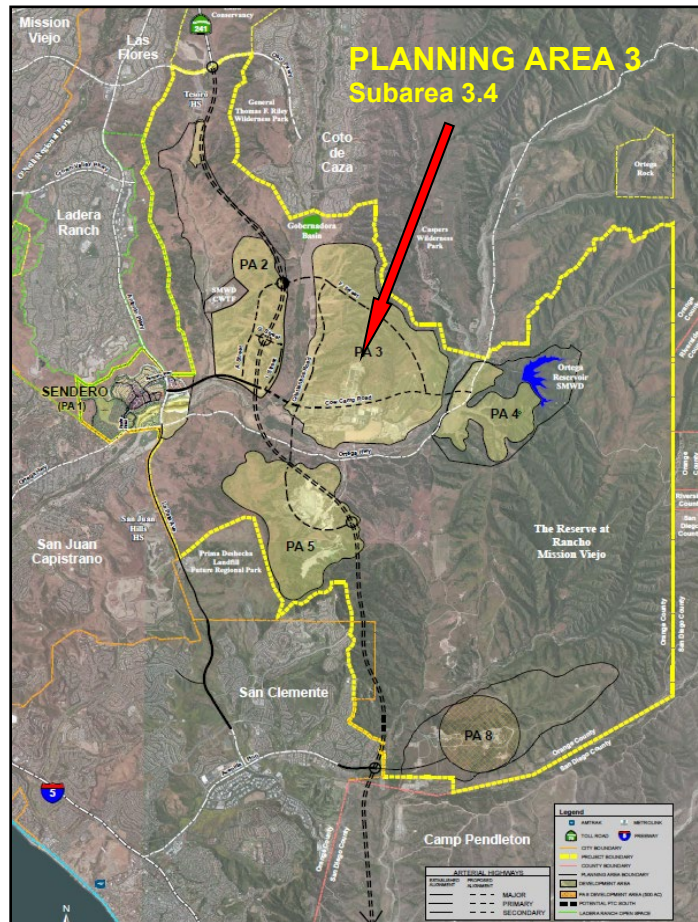

Exhibit 1 – General Vicinity Map

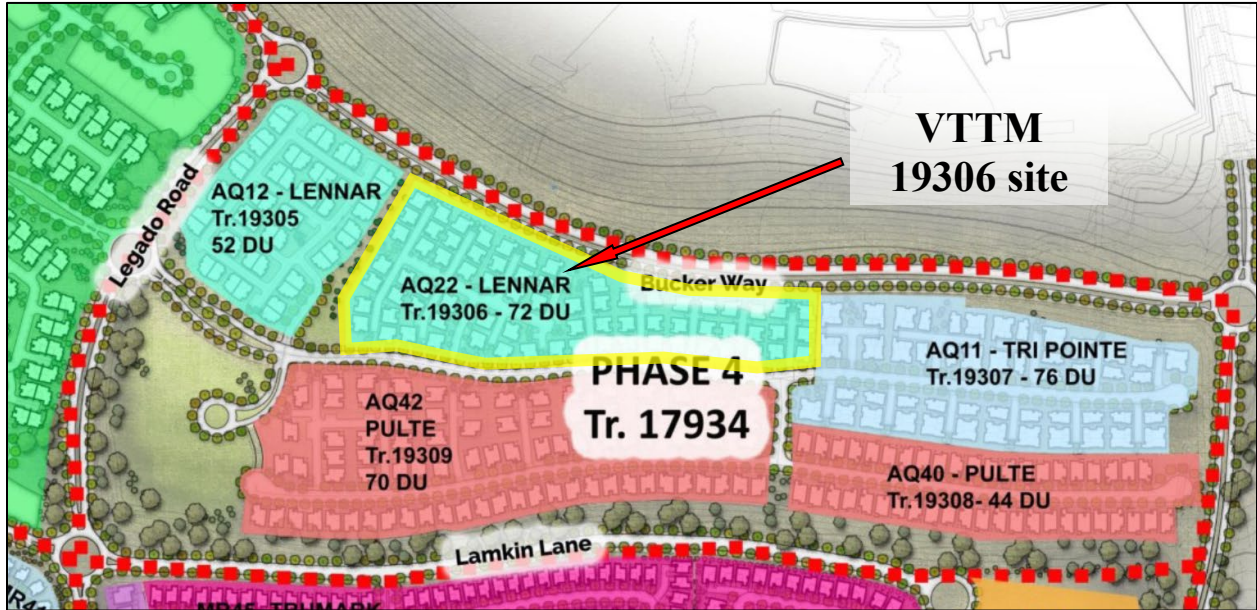

Exhibit 2 – Project Site Map

DISCUSSION/ANALYSIS:

General Description

The proposed “B” VTTM19306 is a subdivision of a 9.78-acre site within Subarea 3.4 of the Ranch Plan Planned Community into 72 numbered lots for planned concept single-family detached dwellings, 7 lettered lots for usable project open space, 6 lettered lots for private motor courts, and 2 lettered lots for slopes/landscape with general access to the tract provided from Gavilan Ridge. A model complex is proposed for Lots 64 through 72. The tract map has been designed to create individual planned concept single-family detached residential lots oriented around a system of private motor courts. The private motor courts providing access to the individual units have been designated as Lots A through F. Lettered Lots G through I and L though O have been designated for usable project open space, and Lots J and K have been designated for landscape slopes.

Consistency Analysis:

Proposed “B” VTTM19306 is consistent with:

- a. State Subdivision Map Act and County of Orange Subdivision Code and Manual.
- b. General Plan, Land Use Element: 6 Urban Activity Center. The proposed map is consistent with the 6 Urban Activity Center designation.
- c. Zoning: Planned Community. The proposed map is in conformance with the County of Orange Planned Community District regulations as regulated by the Ranch Plan Planned Community Text, statistical summary, and development maps.
- d. Area Plans. The proposed map is consistent with the PA3 Master Area Plan, Subarea Plan 3.4, and the PA3 & 4 Master Area and Subarea Plan Amendment and Addendum (PA24-0104).
- e. CEQA: The proposed map is consistent with Program EIR 589, which was certified on November 8, 2004; Addendum 1.0, approved on July 26, 2006; Addendum 1.1, approved on February 24, 2011; the Planning Area 2 Addendum, approved on March 27, 2013; and Addendum 3.1 approved on February 25, 2015.

- f. Alternative Development Standards: All previously approved Alternative Development Standards that are to be incorporated into the development of Subarea 3.4 are listed within the Note #28 on the cover page of proposed VTTM19306.
- g. Regulation Compliance Matrix: Clearance of all applicable conditions of approval have been confirmed per the Ranch Plan Regulation Compliance Matrix.

Estimated Earthwork

The proposed estimated grading quantities for this map are substantially consistent with or less than the earthwork quantities described under previous approvals (i.e., Master Area Plan (PA3), Subarea Plan 3.4, Tract 17934, and related grading permits (GRD22-0016 and GRD23-0059). The proposed grading on this map has been addressed per CEQA document FEIR 589, together with Addendum 3.1.

Drainage:

The subject property is in the Ranch Plan Planned Community Runoff Management Plan (ROMP) Area. A Master Plan of Drainage (MPD) consistent with the PA 3 and 4 ROMP has been established for the project site (Subarea 3.4). VTTM19306 is consistent with this MPD, however no MPD fees are required.

Recreation and Open Space:

The proposed map is not required to provide any improvements or dedications associated with the County Master Plan of Regional Recreation Facilities; Master Plan of Regional Riding and Hiking Trails; Resources Element (Open Space Component); or OCTA Strategic Plan for Bikeways.

- Master Plan of Regional Recreation Facilities - There are no regional park dedication requirements of the subject map.
- Master Plan of Regional Riding and Hiking Trails - There are no riding and hiking trail requirements of the subject map.
- Master Plan of Local Parks (Local Park Code) - The proposed map is required to provide park land in accordance with the Master Plan of Local Parks (Local Park Code) per the parkland generation factor for each unit (greater than 6.5 du/ac requires 0.006 acres and less than 6.5 du/ac requires 0.008 acres). The Local Park Code requirement for the subject map VTTM19306 is 0.43 net usable acres of park land based upon a proposal to build 52 dwelling units at a gross residential density of 7.36 du/ac (72du/9.78 ac). Said requirement can be satisfied by an allocation of parkland credit from Park Modification PM07-01, the Local Park Implementation Plan (LPIP) for the Ranch Plan P.C. originally approved March 14, 2007, 1st Amendment approved in June 2012, 2nd Amendment approved on July 16, 2014, 3rd Amendment approved November 7, 2019 and 4th Amendment approved December 6, 2023.

Per the Ranch Plan LPIP, the total parkland acreage requirement for the entire Ranch Plan Planned Community is 94 acres, based on 14,000 approved dwelling units and the anticipated proportion of single-family and multi-family units. Of the 94 acres required, the LPIP indicates 5 acres of parkland are required for Subarea 3.4. Recorded "A" Final Tract Map 17934, for Subarea 3.4, includes private park easements for the development of a recreation center and a linear park totaling 6.29 acres, which exceeds the parkland requirement for Subarea 3.4. Therefore, there are no additional parkland dedication requirements applicable to the subject map VTTM19306.

- Resources Element - Open Space Component - There are no open space dedication requirements applicable to the subject map.
- OCTA Strategic Plan for Bikeways - There are no County-wide bikeways identified within the area of this map.

Public Services & Utilities

- Schools - This property is within the boundaries of the Capistrano Unified School District. The developer is subject to the provisions of Assembly Bill AB 2926 or other mitigating measures designed to provide for school facilities and/or funding, such as community facilities districts, as outlined by Mitigation Measure 4.15-5 of FEIR 589.
- Facilities Fees Programs - This project area is included within the Ranch Plan Planned Community Development Agreement DA04-01 which phases development commensurate with public services and facilities.
- Water/Sewer - This project is within the boundaries of the Santa Margarita Water District. The District stated in their Preliminary Water Sewer Letter dated June 7, 2024 that the District will be capable of providing water and sewage disposal service to this development.
- Water Quality Control - This project will be required to operate in accordance with requirements prescribed by the California Regional Water Quality Control Board, San Diego Region, as outlined by Standard Conditions 4.5-3 thru 4.5-11 of FEIR 589.
- Fire Protection and Safety - Existing and proposed fire protection services will be providing an adequate level of fire protection services to this development. Additionally, this property is within the area covered by the approved Ranch Plan Fire Protection Program, which includes all applicable conditions of approval and regulations.
- County Service Area (CSA) - This property is within the boundaries of County Service Area No. 26.

Traffic/Circulation

- Scenic Highway Corridors - There are no Scenic Highways applicable to this map.
- Access/Highways/Streets/Roads - Access to the site is via Gavilan Ridge, a public street. Internal tract access will be provided by private streets, Spirit Road and Inspiration Drive, along with private motor courts.
- Major Thoroughfare and Bridge Fee Program - This project lies within the area of benefit of the Foothill/Eastern Transportation Corridor. The developer is required to pay Foothill/Eastern Major Thoroughfare and Bridge fees in accordance with the adopted program.
- Off-Site Fee Program – The project lies within the area of benefit of the South County Roadway Improvement Road Fee Program (SCRIP). The developer is required to pay SCRIP fees in accordance with the adopted program.
- To ensure that necessary ingress and egress easements are provided and maintained along the proposed streets and alleys with the Final Map, Condition of Approval #7 requires the developer to demonstrate on the Final Map, subject to the satisfaction of the Land Development Manager, that improvements will not be constructed within the ingress and egress easements, which could interfere with the use and/or maintenance of the easement.

Fire Master Plan

The applicant has provided a copy of the Orange County Fire Authority (OCFA) Fire Master Plan, Service Request number 544565, approved on June 3, 2024. OCFA has reviewed the proposed project and concurs with the proposal. OCFA and Land Development will continue to coordinate necessary plan check reviews during the permitting and construction process to ensure the development of VTTM 19306 in compliance with associated fire safety and fire protection requirements.

Multiple Final Map Phasing

As indicated on the Map under Note #21 of the title sheet VTTM19306, the option of multiple final maps phasing has been requested as part of the approval of this Vesting Tentative Tract Map.

ALTERNATIVE DEVELOPMENT STANDARDS:

As allowed by General Regulation #25 of the Ranch Plan Planned Community Program Text, proposed Alternative Development Standards are intended to be incorporated into the development as listed within the “Notes” portion of the cover page of VTTM19306. The following approved Ranch PC Alternative Development Standards (approved May 22, 2024) are proposed as part of VTTM19306:

- A-11 Curb Returns at each Residential Driveway
- A-20 Alternative Neighborhood Sidewalk Detail Curb-Separated Walkway
- B-2 Intersection Sight Line Standards
- B-8 Corner Ramp Condition Typical Intersection
- B-9 Modified Color of Curb Ramp Detectable Warning Surface
- D-3 Reduced “Senior Citizen” Parking
- D-8 Planned Concept Detached Dwellings Greater Than 3,000 SF
- G-4 1” Ribbon Curb on Private Streets
- G-7 Reduced Local Depression on Private Streets
- G-8 Reduced Local Depression on Public Streets
- G-9 Rolled Curb on Private Streets
- G-10 Grated Inlets Catch Basins with Rolled Curb on Private Streets
- G-11 Reduced Local Depression with Rolled Curb on Private Streets
- J-5 Class III NEV Route

REFERRAL FOR COMMENT AND PUBLIC NOTICE:

Copies of the vesting tentative tract map submittal package were distributed for review and comment to County staff and consultants, including Land Development, Traffic Engineering, Development Support, Survey, Operations & Maintenance, Building & Safety and the Orange County Fire Authority. Through a collaborative effort with County staff, the applicant adequately addressed all comments. As of the writing of this staff report, no further comments have been received from any County divisions.

A Notice of Public Hearing was mailed to all property owners of record within 300 feet of the subject site on November 7, 2024. Additionally, notices were posted at the site, at the County Administrations North (CAN) Building, and on the Orange County Public Works website as required by established public hearing posting procedures. No public comments have been received to date.

CEQA COMPLIANCE:

The proposed project is covered by previous CEQA documentation, which includes Final Program EIR 589, which was certified on November 8, 2004; Addendum 1.0, approved on July 26, 2006; Addendum 1.1, approved on February 24, 2011; the Planning Area 2 Addendum, approved on March 27, 2013; and Addendum 3.1, approved February 25, 2015. This finding is appropriate and complies with the intent of CEQA, pursuant to the Orange County 2020 Local CEQA Procedures Manual, Section 13.1 for projects where a previous environmental document (i.e., Program EIR 589) is already in place. Further CEQA evaluation and clearances are not required for proposed “B” VTTM19306.

CONCLUSION:

Based on the review of the subject submittal, staff supports approval of the applicant’s proposed “B” Vesting Tentative Tract Map 19306 (VTTM19306) pursuant to the Orange County Subdivision Code, Orange County Codified Ordinances (OCCO) Subarticle 5 (Processing Procedures for Tentative Maps).

Submitted by:

Signed by:

5920734D9EEE4A4...
Robert Zegarra, Contract Planner
Land Development, OC Development Services

Concurred by,

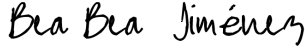
DocuSigned by:

9EEAFDF5701C43D...
Bea Bea Jiménez, Division Manager
Land Development, OC Development Services

CERTIFICATION:

I hereby certify that the Tentative Tract Map 19306 was approved by the Orange County Subdivision Committee on November 20, 2024, per the findings in Appendix A and the conditions in Appendix B.

Lily Sandberg,
Subdivision Committee Chairperson

APPENDICES:

- A. Recommended Findings
- B. Recommended Conditions of Approval
- C. Ranch Plan Regulation Compliance Matrix - “B” Map Items

ATTACHMENTS:

- 1. Applicant’s Letter of Proposal
- 2. Will Serve Letter
- 3. Project Plans and Fire Master Plan

APPEAL PROCEDURE:

Any interested person may appeal the decision of the Subdivision Committee on this application to the Orange County Planning Commission within 10 calendar days of the decision upon submittal of required documents and a filing fee of \$500.00 filed at the Development Processing Center, 601 N. Ross St., Santa Ana. If you challenge the action taken on this proposal in court, you may be limited to raising only those issues you or someone else raised in written correspondence delivered to OC Development Services.

APPENDIX A



Appendix A Findings

VTTM 19306

1 EIR AND ADDENDUM VTTM 19306 (Custom)
 That the decision-maker has considered Final EIR 589, previously certified on November 8, 2004; Addendum 1.0 (PA060023) approved July 2006; Addendum 1.1 (PA110002-PA110006) approved February 24, 2011; the Planning Area 2 Addendum (PA130001-PA130004 and PA130006) approved on March 27, 2013; Addendum 3.1 (PA140072-81) approved February 25, 2015; and the Planning Area 3 & 4 Amendment and Addendum (PA180030) approved September 11, 2019 prior to project approval. The addendums are approved for the proposed project based upon the following findings:

- a. Together, these documents are adequate to satisfy the requirements of CEQA by the decision-maker;
- b. The additions, clarifications and/or changes to the original document caused by the Addendums, do not raise new significant issues which were not addressed by the EIR and none of the conditions described in CEQA Guidelines Section 15162 applies; and
- c. The consideration of the EIR and approval of the Addendums for the proposed project reflect the independent judgment of the Lead Agency.

2 ENVIRONMENTAL MONITORING VTTM 19306 (Custom)
 That the monitoring requirements of Public Resources Code Section 21081.6 (AB 3180) will be considered as having been met in that the design of the subject project, the satisfaction of the requirements of the County's building, grading, fire, and other codes and ordinances and the satisfaction of the conditions of approval applied to the project will implement the mitigation measures contained in EIR No. 589, Addendum 1 (PA06-0023), Addendum 1.1 (PA110003-0006), the Planning Area 2 Addendum (PA130001-0004 and PA130006), Addendum 3.1 (PA140072-81), and the Planning Area 3 & 4 Amendment and Addendum (PA180030).

3 GENERAL PLAN CONSISTENCY VTTM 19306
 That the proposed map is consistent with the Orange County General Plan.

4 DESIGN & IMPROVEMENT VTTM 19306
 That the design and improvement of the proposed subdivision are consistent with the Orange County General Plan.

5 DEVELOPMENT TYPE VTTM 19306
 That the proposed site is physically suitable for the proposed type of development.

6 DEVELOPMENT DENSITY VTTM 19306
 That the proposed site is physically suitable for the proposed density of development.

7 ENVIRONMENTAL DAMAGE VTTM 19306
 That the design of the subdivision or the proposed improvements are not likely to cause substantial environmental damage or substantial and avoidable injury to fish or wildlife or their habitat.

8 PUBLIC HEALTH VTTM 19306
 That the design of the subdivision and the type of improvements proposed are not likely to cause serious public health problems.

9 PUBLIC EASEMENTS VTTM 19306
 That the design of the subdivision and the type of improvements proposed will not conflict with easements of record or established by court judgment acquired by the public-at-large for access through or use of property within the proposed subdivision.

10 SUBDIVISION / ZONING CODE CONSISTENCY VTTM 19306
 That the proposed subdivision complies with the requirements set forth in the Orange County Subdivision Code and the Orange County Zoning Code.

11 ZONING CONSISTENCY VTTM 19306
 That the design and improvement of the proposed subdivision are suitable for the uses proposed, and the subdivision can be developed in compliance with applicable zoning regulations pursuant to Section 7-9-254 of the Subdivision Code.

12 SEWER SYSTEM VTTM 19306 (Custom)
 That the discharge of waste from the proposed subdivision into the existing sewer system of the Water District will not result in violations of existing requirements prescribed by the California Regional Water Quality Control Board, San Diego Region.

13 NATURAL HEATING AND COOLING VTTM 19306
 That the design of the subdivision and its improvements do provide, to the extent feasible, for future passive or natural heating or cooling opportunities as specified in Section 66473.1 of the Government Code (Subdivision Map Act).

14 FEE PROGRAMS VTTM 19306
 That the following determinations apply to fees required by Sections 7-9-700 through 713, Codified Ordinances of Orange County:

- A. Purpose of fees: Fire protection, paramedic, law enforcement, library, and general County services.
- B. Use of fees: Construction of new fire station, sheriff substation, library, and general County facilities in newly developing areas which have inadequate service.
- C. Relationship between use of fees and type of development: Dwelling units and commercial/industrial structures and their occupants require fire protection, paramedic, law enforcement, library, and general County services.
- D. Relationship between need for facilities and type of project: Project is located in newly developing area which has inadequate fire protection, paramedic, library services, and sheriff substation and general County facilities.
- E. Relationship between amount of fees and cost of the portion of the facilities attributable to the development: Fees represent project's pro rata share of the cost of the fire station, sheriff substation, library, and general County facilities.

15

EXPIRATION OF MAPS**VTTM 19306**

That because of participation in fee programs for off-site improvements, this project will qualify for consideration under Section 66452.6 of the Subdivision Map Act.

16

LOCAL PARK CODE**VTTM 19306 (Custom)**

That the Local Park Code requirement can be met by an allocation of park lands credit from PM 07-01, the park implementation plan for the Ranch Plan Planned Community.

17

DEVELOPMENT AGREEMENT**VTTM 19306**

That the Development Agreement DA04-01 contains provisions requiring developer participation in fee programs, facility construction and development phasing and is therefore in compliance with the adopted Growth Management Element in terms of public services and facilities being made available to accommodate development.

18

APPEAL OF EXACTIONS**VTTM 19306**

That the applicant is hereby provided notice that the fees, dedications, reservations or other exactions imposed on this project are as described in this approval as well as the reports and actions accompanying this approval and that the 90-day approval period in which the applicant may protest pursuant to Government Code Section 66020 has begun.

APPENDIX B



Appendix B Conditions of Approval VTTM 19306

1 RANCH PLAN REGULATION COMPLIANCE MATRIX VTTM 19306 (Custom)

The applicant shall comply with all applicable requirements of the Ranch Plan Regulation Compliance Matrix: to the satisfaction of the appropriate decision maker listed in each applicable Regulation Compliance Matrix item. The applicable requirements are listed below and attached as Appendix C:

a. Prior to Recordation:

139: EIR 589 Mitigation Measure 4.9-27 – Invasive Plants CC&R Prohibition
 524: EIR 589 Stand. Cond. 4.4-3 (G04) – Off-site Letter of Consent (if necessary)
 527 & 527.1: EIR 589 Standard Condition 4.5-1 (D01a) – Drainage Study
 528 & 528.1: EIR 589 Standard Condition 4.5-2 (D02a) – Drainage Improvements
 529: EIR 589 Standard Condition 4.5-2 (D02a) – Drainage Improvements
 532: EIR 589 Standard Condition 4.5-4 (D04b) – Master Plan of Drainage
 533: EIR 589 Standard Condition 4.5-5 (D06b) – Subordination of Easements
 534: EIR 589 Standard Condition 4.5-5 (D06b) – SMWD Easements
 535: EIR 589 Standard Condition 4.5-6 (D07b) – Regional Facility Improvements
 537 & 537.1: EIR 589 St. Cond. 4.5-8 (WQ01) – Water Quality Management Plan (WQMP)
 538: EIR 589 St. Cond. 4.5-8 (WQ03) – Water Quality Management Plan (WQMP)
 544: EIR 589 Standard Condition 4.6-2 (T01) – Vehicular Access Rights
 545: EIR 589 Standard Condition 4.6-3 (T02) – Private Street Improvements
 546: 546.1: 546.2 & 546.3: SC 4.6-4: (T04) – Street Improvements
 549: EIR 589 Standard Condition 4.6-7 (T08) – Traffic Signal Conduit
 550, 550.1, 550.2 & 550.3: EIR 589 Stand. Cond. 4.6-8 (T12) – Internal Circulation
 551: EIR 589 Standard Condition 4.6-9 (T13b) – Traffic Signal Maintenance Easement
 552: EIR 589 Standard Condition 4.6-10 (T14b) – Traffic Signal Installation
 559 & 559.1: EIR 589 Standard Condition 4.8-3 (N01) – Sound Attenuation
 589.1: EIR 589 Standard Condition 4.15-1 – Water Improvement Plans
 597: EIR 589 Standard Condition 4.15-9 – Capistrano Unified School District fees
 619: Ranch Plan Fire Prot. Program Cond. 4 – OCFA Administrative Approval

b. Prior to Approval of Site Development Permit

109: EIR 589 Mitigation Measure 4.7-3 – Shade Trees in Parking Lot Design
 110: EIR 589 Mitigation Measure 4.7-3 – Use of Light-Colored Roof Materials

c. Prior to Issuance of Grading Permits

521: EIR 589 Standard Condition 4.4-1 (G01) – Geotechnical report
 522: EIR 589 Standard Condition 4.4-2 (G02) – Conformance with TT Map
 523: EIR 589 Standard Condition 4.4-2 (G02) – Revised TT Map (if necessary)
 524: EIR 589 Stand. Cond. 4.4-3 (G04) – Off-site Letter of Consent (if necessary)
 525: EIR 589 Standard Condition 4.4-4 (G09) – Consistency with Planning Approval
 527 & 527.1: EIR 589 Standard Condition 4.5-1 (D01a) – Drainage Study
 528 & 528.1: EIR 589 Standard Condition 4.5-2 (D02a) – Drainage Improvements
 530 & 530.1: EIR 589 Standard Condition 4.5-3 (D02b) – Drainage Improvements
 537 & 537.1: EIR 589 St. Cond. 4.5-8 (WQ01) – Water Quality Management Plan (WQMP)
 538: EIR 589 St. Cond. 4.5-8 (WQ03) – Water Quality Management Plan (WQMP)
 540: EIR 589 St. Cond. 4.5-10 (WQ04) – Stormwater Pollution Prevention (SWPPP)
 541: EIR 589 St. Cond. 4.5-11 (WQ05) – Erosion and Sediment Control Plan
 548: EIR 589 Standard Condition 4.6-6 (T07) – Sight Distance
 555, 555.1 through 555.5: EIR 589 Standard Condition 4.7-1 – Fugitive Dust
 556, 556.1, 556.2 & 556.3: EIR 589 Standard Condition 4.7-2 – Emission Control
 557: EIR 589 Standard Condition 4.8-1 (N10) – Hours of Construction
 558, 558.1, 558.2, 558.3 & 558.4: EIR 589 St. Condition. 4.8-2 (N10) – Construction Noise
 559 & 559.1: EIR 589 Standard Condition 4.8-3 (N01) – Sound Attenuation
 567: EIR 589 Standard Condition 4.10-2 (LA02b) – Private Area Landscaping
 571: EIR 589 Standard Condition 4.11-1 (A04) – Archaeology Grading Observation and Salvage
 574: EIR 589 Standard Condition 4.11-2 (A07) – Paleontology Resource Surveillance
 589: EIR 589 Standard Condition 4.14-2 – Hazardous Materials
 616: Ranch Plan Fire Prot. Program Cond. 3.d. – Precise Fuel Modification Plan

d. Prior to Precise Fuel Modification Plans:

138: EIR 589 Mitigation Measure 4.9-27 – Invasive Plants and Fuel Modification

e. Prior to Issuance of Building Permit:

111: EIR 589 Mitigation Measure 4.7-3 – Use of Light-Colored Roof Materials
 140: EIR 589 Mitigation Measure 4.9-28 – Open Space habitat, light shields
 206: EIR 589 Mitigation Measure 4.15-5 – Capistrano Unified School District fees
 526: EIR 589 Standard Condition 4.4-5 – Compliance with Code
 537 & 537.1: EIR 589 St. Cond. 4.5-8 (WQ01) – Water Quality Management Plan (WQMP)
 538: EIR 589 St. Cond. 4.5-8 (WQ03) – Water Quality Management Plan (WQMP)
 540: EIR 589 St. Cond. 4.5-10 (WQ04) – Stormwater Pollution Prevention (SWPPP)
 541: EIR 589 St. Cond. 4.5-11 (WQ05) – Erosion and Sediment Control Plan
 547: EIR 589 Standard Condition 4.6-5 (T05) – Major Thoroughfare & Bridge Fees
 550, 550.1, 550.2 & 550.4: EIR 589 Standard Condition 4.6-8 (T12) – Internal Circulation
 559.2 & 559.3: EIR 589 Standard Condition 4.8-3 (N01) – Sound Attenuation
 564 & 564.1: EIR 589 Standard Condition 4.10-1 (LA01b) – Public Area Landscaping
 570: EIR 589 Standard Condition 4.10-3 (LG01) – Light and Glare
 589: EIR 589 Standard Condition 4.14-2 – Hazardous Materials
 617: Ranch Plan Fire Prot. Program Cond. 3.e. – Vegetation Clearance

f. Prior to Combustible Construction:
609: Ranch Plan Fire Prot. Program Cond. 2.d. – Emergency Access & Water Supply

g. During Construction:
197: EIR 589 Mitigation Measure 4.14-13 – ESA Remedial Measures

h. Prior to Certificates of Occupancy:
529: EIR 589 Standard Condition 4.5-2 (D02a) – Drainage Improvements
531: EIR 589 Standard Condition 4.5-3 (D02b) – Drainage Improvements
539, 539.1 & 539.2: EIR 589 Standard Condition 4.5-9 (WQ03) – Compliance with Water Quality Management Plan (WQMP)
560: EIR 589 Standard Condition 4.8-4 (N09) – Multi-Family Residential Development
563: EIR 589 Standard Condition 4.8-7 (N12) – Transportation Corridor Notification
565 & 566: EIR 589 Standard Condition 4.10-1 (LA01b) – Public Area Landscaping
568 & 569: EIR 589 Standard Condition 4.10-2 (LA02b) – Private Area Landscaping
618: Ranch Plan Fire Prot. Program Cond. 3.f. - Fuel Modification Zones

i. Prior to Release of Grading Bond:
572 & 573: EIR 589 Standard Condition 4.11-1 (A04) – Archaeology Grading Observation and Salvage
575 & 576: EIR 589 Standard Condition 4.11-2 (A07) – Paleontology Resource Surveillance

2 WATER QUALITY MANAGEMENT PLAN VTTM 19306

Prior to the issuance of any grading or building permits, the applicant shall submit for review and approval by the Manager, Permit Services, a Water Quality Management Plan (WQMP) specifically identifying Best Management Practices (BMPs) that will be used onsite to control predictable pollutant runoff. The applicant shall utilize the Orange County Drainage Area Management Plan (DAMP), Model WQMP, and Technical Guidance Manual for reference, and the County’s WQMP template for submittal. This WQMP shall include the following:

- Detailed site and project description
- Potential stormwater pollutants
- Post-development drainage characteristics
- Low Impact Development (LID) BMP selection and analysis
- Structural and Non-Structural source control BMPs
- Site design and drainage plan (BMP Exhibit)
- GIS coordinates for all LID and Treatment Control BMPs
- Operation and Maintenance (O&M) Plan that (1) describes the long-term operation and maintenance requirements for BMPs identified in the BMP Exhibit; (2) identifies the entity that will be responsible for long-term operation and maintenance of the referenced BMPs; and (3) describes the mechanism for funding the long-term operation and maintenance of the referenced BMPs

The BMP Exhibit from the approved WQMP shall be included as a sheet in all plan sets submitted for plan check and all BMPs shall be depicted on these plans. Grading and building plans must be consistent with the approved BMP exhibit.

3 BEST MANAGEMENT PRACTICES VTTM 19306 (Custom)

Prior to issuance of a building permit, the off-site regional Best Management Practices (BMPs) relied upon by this project (e.g., basins, swales, etc.) must be built and/or installed, and operational. The location and operation of these regional BMPs must be in compliance with the Final Project-Specific WQMP for the regional BMP(s). The location and operation of the regional BMP(s) must be demonstrated to the satisfaction of the Manager, Grading and Building Plan Check.

4 COMPLIANCE WITH THE NPDES IMPLEMENTATION VTTM 19306 PROGRAM

Prior to the issuance of a certificate of use and occupancy, the applicant shall demonstrate compliance with the County’s NPDES Implementation Program in a manner meeting the satisfaction of the Manager, OC Inspection, including:

- Demonstrate that all structural Best Management Practices (BMPs) described in the BMP Exhibit from the project’s approved WQMP have been implemented, constructed and installed in conformance with approved plans and specifications
 - Demonstrate that the applicant has complied with all non-structural BMPs described in the project’s WQMP
 - Submit for review and approval an Operations and Maintenance (O&M) Plan for all structural BMPs (the O&M Plan shall become an attachment to the WQMP.
 - Demonstrate that copies of the project’s approved WQMP (with attached O&M Plan) are available for each of the initial occupants.
 - Agree to pay for a Special Investigation from the County of Orange for a date twelve (12) months after the issuance of a Certificate of Use and Occupancy for the project to verify compliance with the approved WQMP and O&M Plan
 - Demonstrate that the applicant has RECORDED one of the following:
 1. The CC&R’s (that must include the approved WQMP and O&M Plan) for the project’s Homeowner’s Association.
 2. A water quality implementation agreement that has the approved WQMP and O&M Plan attached; or
 3. The final approved Water Quality Management Plan (WQMP) and Operations and Maintenance (O&M) Plan.
- (Appendix C - Items 539, 539.1, 539.2)

5 INDEMNIFICATION VTTM 19306 (Custom)

Applicant shall defend with counsel approved by the County of Orange in writing, indemnify and hold harmless the County of Orange, its officers, agents and employees from any claim, action or proceeding against the County, its officers, agents or employees to attack, set aside, void, or annul any approval of the application or related decision, or the adoption of any environmental documents, findings or other environmental determination, by the County of Orange, its Board of Supervisors, Planning Commission, Zoning Administrator, Director of OC Public Works, or Director of Planning concerning this application. The County may, at its sole discretion, participate in the defense of any action, but such participation shall not relieve applicant of his/her obligations under this condition. Applicant shall reimburse the County for any court costs and attorney’s fees that the County may be required to pay as a result of such action. The County shall promptly notify the applicant of any such claim, action or proceeding.

6 BUYER NOTIFICATION MAP VTTM 19306 (Custom)

Prior to the issuance of any building permits for residential construction, the developer RMV Community Development, LLC, shall prepare a map denoting the existing and proposed land uses, arterial highways, and public facilities within the surrounding area for the approval of the Manager, OC Planning. The map content, display, and distribution shall be in accordance with the Buyer Notification Program guidelines listed in Board of Supervisors Resolution 82-1368 and as amended.

7

MANEUVERABILITY EASEMENT

VTTM 19306 (Custom)

Prior to recordation of the final tract map, the subdivider shall demonstrate that all necessary ingress/egress easements for vehicle maneuverability within motor courts/alleyways are identified on the final map subject to the satisfaction of the Manager, Land Development. The easement shall prohibit property owners from installing any improvements within the easement area or interfering with the use or maintenance of the easement.

APPENDIX C

Item No.	Cross Reference Column	Source	Condition, Mitigation, Public Benefit or Entitlement Provision	Timing	Subject	Keywords	Title	Requirements or Entitlement Provisions	Reviewing / Approving Authority (Advisory Agency in Parentheses)	Form of Compliance	Guidance for Compliance	Area Application
a. Prior to Recordation												
139	137-138 (EIR 589, MM 4.9-27)	EIR 589	MM 4.9-27 (cont.)	Prior to the recordation of a map for tract adjacent to the RMV Open Space	Biological Resources	CC&Rs, California Exotic Pest Plant Council	Invasive Plants CC&R Prohibition	b. Prior to the recordation of a map for a tract adjacent to the RMV Open Space, the County of Orange shall verify that the CC&Rs contain language prohibiting the planting of plants identified by the California Exotic Pest Plant Council as an invasive risk in Southern California in private landscaped areas.	Director, PDS Director, OC Planning	Provide letter stating that CC&Rs contain language prohibiting the planting of plants on most current California Invasive Plant Inventory	To be cleared for entire Planned Community, upon providing RMV CC&R summary letter [Hyperlink #13] stating CC&Rs contain language prohibiting the planting of plants on most current California Invasive Plant Inventory (www.cal-ipc.org) in private landscape areas. Only applies to recordation of tract maps that include lots located immediately adjacent to RMV Open Space	Each PA
524		EIR 589	SC 4.4-3	Prior to the recordation of a subdivision map or prior to issuance of a Grading Permit, whichever comes first	Geology and Soils (cont.):		Geology and Soils (cont.):	Prior to the recordation of a subdivision map or prior to the issuance of any grading permit, whichever comes first, and if determined necessary by the County of Orange Manager, Subdivision and Grading, the applicant shall record a letter of consent from the affected property owners permitting off-site grading, cross lot drainage, drainage diversions and/or unnatural concentrations. The applicant shall obtain approval of the form of the letter of consent from the Manager, Subdivision and Grading Services before recordation of the letter. (County Standard Condition G04)	County of Orange Director of Planning & Development Services, Director, OC Planning	Recordation of a letter of consent from affected property owners if determined necessary by County of Orange Director of Planning & Development Services		Each PA
527		EIR 589	SC 4.5-1	Prior to recordation of a Subdivision Map or issuance of a Grading Permit, whichever comes first	Drainage Study:		Drainage Study:	Prior to the recordation of a subdivision map (except maps for financing and conveyance purposes only) or prior to the issuance of any grading permits, whichever comes first, the following drainage studies shall be submitted to and approved by the Manager, Subdivision and Grading: (County Standard Condition D01a)	County of Orange Director of Planning & Development Services, Director, OC Planning	Submittal of satisfactory of drainage study		Each PA

Item No.	Cross Reference Column	Source	Condition, Mitigation, Public Benefit or Entitlement Provision	Timing	Subject	Keywords	Title	Requirements or Entitlement Provisions	Reviewing / Approving Authority (Advisory Agency in Parentheses)	Form of Compliance	Guidance for Compliance	Area Application
527.1		EIR 589	SC 4.5-1 (cont.)	See above	Drainage Study (cont.):		Drainage Study (cont.):	A. A drainage study of the project including diversions, off-site areas that drain onto and/or through the project, and justification of any diversions; and B. When applicable, a drainage study evidencing that proposed drainage patterns will not overload existing storm drains; and C. Detailed drainage studies indicating how the project grading, in conjunction with the drainage conveyance systems including applicable swales, channels, street flows, catch basins, storm drains, and flood water retarding, will allow building pads to be safe from inundation from rainfall runoff which may be expected from all storms up to and including the theoretical 100-year flood. (County Standard Condition D01a)	See above	See above		Each PA
528		EIR 589	SC 4.5-2	Prior to recordation of a Subdivision Map or Issuance of a Grading Permit, whichever comes first	Drainage Improvements:		Drainage Improvements:	A. Prior to the recordation of a subdivision map (except maps for financing and conveyance purposes only) or prior to the issuance of any grading permits, whichever comes first, the applicant shall in a manner meeting the approval of the Manager, Subdivision and Grading: (County Standard Condition D02a)	County of Orange Director of Planning & Development Services, Director, OC Planning	Approval of storm drain drainage plans and offer(s) of dedication, if necessary		Each PA
528.1		EIR 589	SC 4.5-2 (cont.)	See above	Drainage Improvements (cont.):		Drainage Improvements (cont.):	1) Design provisions for surface drainage; 2) Design all necessary storm drain facilities extending to a satisfactory point of disposal for the proper control and disposal of storm runoff; and 3) Dedicate the associated easements to the County of Orange, if determined necessary. (County Standard Condition D02a)	See above	See above		Each PA

Item No.	Cross Reference Column	Source	Condition, Mitigation, Public Benefit or Entitlement Provision	Timing	Subject	Keywords	Title	Requirements or Entitlement Provisions	Reviewing / Approving Authority (Advisory Agency in Parentheses)	Form of Compliance	Guidance for Compliance	Area Application
529		EIR 589	SC 4.5-2 (cont.)	Prior to recordation of a Subdivision Map or Issuance of a Certificate of Use and Occupancy, whichever comes first	Drainage Improvements (cont.):		Drainage Improvements (cont.):	B. Prior to the recordation of a subdivision map (except maps for financing and conveyance purposes only) or prior to the issuance of any certificates of use and occupancy, whichever occurs first, said improvements shall be constructed in a manner meeting the approval of the Manager, Construction. (County Standard Condition D02a)	County of Orange Manager of Inspection- Manager, OC Inspection Division	Verification of construction of drainage improvement		Each PA
532		EIR 589	SC 4.5-4	Prior to the recordation of a Subdivision Map (except maps for financing and conveyance purposes only)	Master Plan of Drainage:		Master Plan of Drainage:	Prior to the recordation of a subdivision map (except maps for financing and conveyance purposes only), the subdivider shall participate in the applicable Master Plan of Drainage in a manner meeting the approval of the Manager, Subdivision and Grading, including payment of fees and the construction (or provide evidence of financial security, such as bonding) of the necessary facilities. (County Standard Condition D04b)	County of Orange Director of Planning & Development Services- Director, OC Planning	Verification of participation in Master Plan of Drainage (fees and/or improvements)	See guidance above related to Item No. 30.	Each PA
533		EIR 589	SC 4.5-5	Prior to the recordation of a Subdivision Map	Subordination of Easements:		Subordination of Easements:	Prior to the recordation of a subdivision map (except maps for financing and conveyance purposes only), the subdivider shall not grant any easements over any property subject to a requirement of dedication or irrevocable offer to the County of Orange or the Orange County Flood Control District, unless such easements are expressly made subordinate to the easements to be offered for dedication to the County. Prior to granting any of said easements, the subdivider shall furnish a copy of the proposed easement to the Manager, Subdivision and Grading, for review and approval. (County Standard Condition D06b)	County of Orange Director of Planning & Development Services- Director, OC Planning (Orange County Flood Control District and Santa Margarita Water District)	Verification that any granted easements are subordinate to easements offered to County and provision of copy of said easement(s)	Except in those cases where the County of Orange and the public entity grantee have previously mutually agreed upon conditions to coexist within the easement area.	Each PA

Item No.	Cross Reference Column	Source	Condition, Mitigation, Public Benefit or Entitlement Provision	Timing	Subject	Keywords	Title	Requirements or Entitlement Provisions	Reviewing / Approving Authority (Advisory Agency in Parentheses)	Form of Compliance	Guidance for Compliance	Area Application
534		EIR 589	SC 4.5-5 (cont.)	See above	Subordination of Easements (cont.):		Subordination of Easements (cont.):	The Santa Margarita Water District would restore other improvements or facilities located within the easement, if it has consented to the location of such improvements or facilities to the extent that the exercise of its rights in connecting with the easement impacts other improvements of facilities located within the easement; however, in no event shall Santa Margarita Water District be responsible for the cost of relocating its facilities in event of conflicts with such improvements or facilities. (County Standard Condition D06b)	County of Orange Director of Planning & Development Services Director, OC Planning (Orange County Flood Control District and Santa Margarita Water District)	See above	Except in those cases where the County of Orange and the public entity grantee have previously mutually agreed upon conditions to coexist within the easement area.	Each PA
535		EIR 589	SC 4.5-6	Prior to County of Orange acceptance of improvements as identified by separate agreement the recordation of a Subdivision Map	Regional Facility Improvements:		Regional Facility Improvements:	Prior to County of Orange acceptance of improvements as identified by separate agreement the recordation of a subdivision map, the applicant shall improve Regional Facility _____ by the construction (or evidence of financial security, such as bonding) of _____, an IOD shall be recorded offering said improvements and dedicate right-of-way to the Orange County Flood Control District in a manner meeting the approval of the Manager, Subdivision and Grading. County of Orange to accept IOD upon satisfactory completion of improvements. (County Standard Condition D07b, modified)	County of Orange Director of Planning & Development Services Director, OC Planning (Orange County Flood Control District and Santa Margarita Water District)	Verification of construction and/or offer(s) of dedication for flood control improvements		Each PA

Item No.	Cross Reference Column	Source	Condition, Mitigation, Public Benefit or Entitlement Provision	Timing	Subject	Keywords	Title	Requirements or Entitlement Provisions	Reviewing / Approving Authority (Advisory Agency in Parentheses)	Form of Compliance	Guidance for Compliance	Area Application
537		EIR 589	SC 4.5-8	Prior to the recordation of a Subdivision Map or the issuance of any Grading or Building Permit, whichever comes first	Water Quality Management Plan:		Water Quality Management Plan:	Prior to the recordation of any final subdivision map (except those maps for financing or conveyance purposes only) or the issuance of any grading or building permit (whichever comes first), the applicant shall submit for review and approval by the Manager, Inspection Services Division, a Water Quality Management Plan (WQMP) specifically identifying Best Management Practices (BMPs) that will be used onsite to control predictable pollutant runoff. This WQMP shall identify, at a minimum, the routine structural and non-structural measures specified in the current Drainage Area Management Plan (DAMP). The WQMP may include one or more of the following: (County Standard Condition WQ01)	County of Orange Director of Planning & Development Services, Director, OC Planning	Submittal of satisfactory Water Quality Management Plan		Each PA
537.1		EIR 589	SC 4.5-8 (cont.)	See above	Water Quality Management Plan (cont.):		Water Quality Management Plan (cont.):	<ul style="list-style-type: none"> • Discuss regional water quality and/or watershed programs (if available for the project); • Address Site Design BMPs (as applicable) such as minimizing impervious areas, maximizing permeability, minimizing directly connected impervious areas, creating reduced or "zero discharge" areas, and conserving natural areas; • Include the applicable Routine Source Control BMPs as defined in the DAMP. (County Standard Condition WQ01) 	See above	See above		Each PA
538		EIR 589	SC 4.5-8 (cont.)	See above	Water Quality Management Plan (cont.):		Water Quality Management Plan (cont.):	Demonstrate how surface runoff and subsurface drainage shall be managed and directed to the nearest acceptable drainage facility (as applicable), via sump pumps if necessary. (Standard Condition of Approval, WQ03)	See above	See above		Each PA

RANCH PLAN REGULATION COMPLIANCE MATRIX GUIDANCE DOCUMENT

Appendix C

PA 3.4 BUILDER "B" MAP REQUIREMENTS SORTED BY MILESTONE

Item No.	Cross Reference Column	Source	Condition, Mitigation, Public Benefit or Entitlement Provision	Timing	Subject	Keywords	Title	Requirements or Entitlement Provisions	Reviewing / Approving Authority (Advisory Agency in Parentheses)	Form of Compliance	Guidance for Compliance	Area Application
544		EIR 589	SC 4.6-2	Prior to the recordation of a Subdivision Map	Vehicular Access Rights:		Vehicular Access Rights:	Prior to the recordation of a subdivision map, the subdivider shall place notes on the final map which release and relinquish vehicular access rights to all arterial highways to the County of Orange, except for access locations approved by the County of Orange, in a manner meeting the approval of the Manager, Subdivision and Grading. (County Standard Condition T01)	County of Orange Director of Planning & Development Services, Director, OC Planning	Verification of notes on the final map which release and relinquish vehicular access rights to all arterial highways to the County of Orange except for access locations approved by the County of Orange	Note shall state: "Rancho Mission Viejo or assigns hereby release and relinquish vehicular access rights to all arterial highways to the County of Orange, except for access locations approved by the County of Orange"	Each PA
545		EIR 589	SC 4.6-3	Prior to the recordation of a Subdivision Map	Private Street Improvements:		Private Street Improvements:	Prior to the recordation of a subdivision map, the subdivider shall place a note on the map, in a manner that meets the approval of the Manager, Subdivision and Grading Services, that states: "The private streets constructed within this map shall be owned, operated and maintained by the developer, successors or assigns. The County of Orange shall have no responsibility therefore unless pursuant to appropriate sections of the Streets and Highways Code of the State of California, the said private streets have been accepted into the County Road System by appropriate resolution of the Orange County Board of Supervisors. (County Standard Condition T02)	County of Orange Director of Planning & Development Services, Director, OC Planning	Verification of a note on the Subdivision Map	Note shall make statement listed in quotations in condition.	Each PA
546		EIR 589	SC 4.6-4	Prior to the recordation of a Subdivision Map	Street Improvements (cont.):		Street Improvements (cont.):	Prior to the recordation of a subdivision map, the subdivider shall design and construct (or provide evidence of financial security, such as bonding) the following improvements in accordance with plans and specifications meeting the approval of the Manager, Subdivision and Grading: (County Standard Condition T04)	County of Orange Director of Planning & Development Services, Director, OC Planning	Submittal of satisfactory improvements and utility plans with verification of subsequent construction/in stallation of improvements	If applicable, bonding may substitute for construction of each of the required improvements.	Each PA
546.1		EIR 589	SC 4.6-4 (cont.)	See above	Street Improvements (cont.):		Street Improvements (cont.):	A. Streets, bus stops, on-road bicycle trails, street names, signs, striping and stenciling. (County Standard Condition T04)	See above	See above	See above	Each PA
546.2		EIR 589	SC 4.6-4 (cont.)	See above	Street Improvements (cont.):		Street Improvements (cont.):	B. The water distribution system and appurtenances shall also conform to the applicable laws and adopted regulations enforced by the County Fire Chief. (County Standard Condition T04)	See above	See above	See above	Each PA
546.3		EIR 589	SC 4.6-4 (cont.)	See above	Street Improvements (cont.):		Street Improvements (cont.):	C. Underground utilities (including gas, cable, electrical and telephone), streetlights, and mailboxes. (County Standard Condition T04)	See above	See above	See above	Each PA

RANCH PLAN REGULATION COMPLIANCE MATRIX GUIDANCE DOCUMENT

Appendix C

PA 3.4 BUILDER "B" MAP REQUIREMENTS SORTED BY MILESTONE

Item No.	Cross Reference Column	Source	Condition, Mitigation, Public Benefit or Entitlement Provision	Timing	Subject	Keywords	Title	Requirements or Entitlement Provisions	Reviewing / Approving Authority (Advisory Agency in Parentheses)	Form of Compliance	Guidance for Compliance	Area Application
549		EIR 589	SC 4.6-7	Prior to the recordation of a Subdivision Map	Traffic Signal Conduit:		Traffic Signal Conduit:	Prior to the recordation of a subdivision map, the subdivider shall install (or provide evidence of financial security, such as bonding, that) all underground traffic signal conduits (e.g., signals, phones, power, loop detectors, etc.) and other appurtenances (e.g., pull boxes, etc.) needed for future traffic signal construction, and for future interconnection with adjacent intersections, all in accordance with plans and specifications meeting the approval of the Manager, Subdivision and Grading. (County Standard Condition T08)	County of Orange Director of Planning & Development Services, Director, OC Planning	Approved traffic signal plans with verification of subsequent installation	If applicable, bonding may substitute for construction of each of the required improvements.	Each PA
550		EIR 589	SC 4.6-8	Prior to the recordation of a Subdivision Map or prior to the issuance of Building Permits, whichever occurs first	Internal Circulation:		Internal Circulation:	A. Prior to the recordation of a subdivision map or the issuance of any building permits, whichever occurs first, the subdivider shall provide plans and specifications meeting the approval of the Manager, Subdivision and Grading, for the design of the following improvements: (County Standard Condition T12)	County of Orange Director of Planning & Development Services,	Submittal of satisfactory street improvement plans		Each PA
550.1		EIR 589	SC 4.6-8 (cont.)	See above	Internal Circulation (cont.):		Internal Circulation (cont.):	1) Internal street common private drive system. (County Standard Condition T12)	See above	See above		Each PA
550.2		EIR 589	SC 4.6-8 (cont.)	See above	Internal Circulation (cont.):		Internal Circulation (cont.):	2) Entrance to the site to emphasize that the development is private by use of signs and other features. (Standard Condition of Approval T12)	See above	See above		Each PA
550.3		EIR 589	SC 4.6-8 (cont.)	Prior to the recordation of Subdivision Map.	Internal Circulation (cont.):		Internal Circulation (cont.):	B. Prior to the recordation of a subdivision map, the applicant shall construct (or provide evidence of financial security, such as bonding) the above improvements in a manner meeting the approval of the Manager, Construction. (County Standard Condition T12)	County of Orange Manager of Inspection, Manager, OC Inspection Division	Verification of improvements' construction in SC 4.6-8A	If applicable, bonding may substitute for construction of each of the required improvements.	Each PA
551		EIR 589	SC 4.6-9	Prior to the recordation of a Subdivision Map	Traffic Signal Maintenance Easement:		Traffic Signal Maintenance Easement:	Prior to the recordation of a subdivision map, the subdivider shall dedicate a signal maintenance easement to the County of Orange at the project site access, in a manner meeting the approval of the Manager, Subdivision and Grading. (County Standard Condition T13b)	County of Orange Director of Planning & Development Services, Director, OC Planning	Submittal of offer(s) of dedication for signal maintenance easement(s)		Each PA

Item No.	Cross Reference Column	Source	Condition, Mitigation, Public Benefit or Entitlement Provision	Timing	Subject	Keywords	Title	Requirements or Entitlement Provisions	Reviewing / Approving Authority (Advisory Agency in Parentheses)	Form of Compliance	Guidance for Compliance	Area Application
552		EIR 589	SC 4.6-10	Prior to the recordation of a Subdivision Map	Traffic Signal Installation:		Traffic Signal Installation:	Prior to the recordation of a subdivision map, the subdivider shall design and construct/provide a cash deposit of ___ % of the cost of / /enter into an agreement with the County of Orange, accompanied by financial security, for the cost of ___ % of) a traffic signal at the intersection of ___ and ___, in a manner meeting the approval of the Manager, Subdivision and Grading. (County Standard Condition T14b)	County of Orange Director of Planning & Development Services, Director, OC Planning	Verification of approved street improvement plans with subsequent installation of improvements or enter into agreement with County for construction (with appropriate financial security)	If applicable, bonding may substitute for construction of each of the required improvements.	Each PA
559		EIR 589	SC 4.8-3	See below	Sound Attenuation:		Sound Attenuation:	The applicant shall sound attenuate all residential lots and dwellings against present and projected noise (which shall be the sum of all noise impacting the project) so that the composite interior standard of 45 dBA CNEL for habitable rooms and a source specific exterior standard of 65 dBA CNEL for outdoor living areas is not exceeded. The applicant shall provide a report prepared by a County-certified acoustical consultant, which demonstrates that these standards will be satisfied in a manner consistent with Zoning Code Section 7-9-137.5, as follows: (County Standard Condition N01)	County of Orange Director of Planning & Development Services and County of Orange Manager of Building Permits Services, Director, OC Planning and Manager, Permit Services (Building Plan Check)	Submittal of satisfactory acoustical analysis	Staff may determine that no attenuation is necessary, and no action is required (as occurred in PA1). In such a case a "not applicable" memo is to be prepared. Applicant and County staff to address AC units in side yards as soon as possible.	Each PA
559.1		EIR 589	SC 4.8-3 (cont.)	Prior to the recordation of a subdivision map or prior to the issuance of grading permits	Sound Attenuation (cont.):		Sound Attenuation (cont.):	a. Prior to the recordation of a subdivision map or prior to the issuance of grading permits, as determined by the Manager, Building Permits Services, the applicant shall submit an acoustical analysis report to the Manager, Building Permits Services, for approval. The report shall describe in detail the exterior noise environment and preliminary mitigation measures. Acoustical design features to achieve interior noise standards may be included in the report in which case it may also satisfy Condition B below. (County Standard Condition N01)	See above	See above		Each PA

RANCH PLAN REGULATION COMPLIANCE MATRIX GUIDANCE DOCUMENT

Appendix C

PA 3.4 BUILDER "B" MAP REQUIREMENTS SORTED BY MILESTONE

Item No.	Cross Reference Column	Source	Condition, Mitigation, Public Benefit or Entitlement Provision	Timing	Subject	Keywords	Title	Requirements or Entitlement Provisions	Reviewing / Approving Authority (Advisory Agency in Parentheses)	Form of Compliance	Guidance for Compliance	Area Application
589.1		EIR 589	SC 4.15-1	Prior to recordation of final tract a-subdivision maps (alternatively subdivider may enter into a subdivision improvement agreement with the County	Water Improvement Plans:		Water Improvement Plans:	Prior to the recordation of a subdivision map, the subdivider shall design and construct (or provide evidence of financial security, such as bonding) water distribution system and appurtenances that conform to the applicable laws and adopted regulations enforced by the County Fire Chief, in accordance with plans and specifications meeting the approval of the Manager, Subdivision and Grading. (Added per MMRP attached to 11/8/06 CEQA Resolution 04-290)	County of Orange Director of Planning & Development Services- Director, OC Planning (OCFA)	Approved water improvement plans with subsequent construction of improvement	Applicant must submit one of the following: (1) approved improvement plan consisted with referenced Plan of Works, (2) letters from both SMWD and OCFA indicating sufficient water supply and pressure for Map area, or (3) subdivision improvement agreement with County.	Each PA
597		EIR 589	SC 4.15-9		CUSD Fees:		CUSD Fees:	Prior to the recordation of final tract map, the project applicant shall provide for the payment of fees pursuant to California Government Code Section 65995, unless other provision are required of the applicant through the agreement with CUSD (see Mitigation Measure 4.15-5).	N/A	Compliance with CUSD agreement	Payment of school fees per CUSD/RMV Agreement	PC-Wide
619		Fire Prot. Prog.	Cond. 4	Prior to recordation of each Tract Map	Administrative Approval of Tract Maps		Administrative Approval of Tract Maps	Prior to recordation of each Tract Map, the applicant shall submit a copy of the proposed Tract map to OCFA for administrative approval (verifying that the map remains consistent with previous approvals), and for OCFA's record keeping purposes.	Director, PDS, Director, OC Planning	Submit a copy of the proposed Tract map to OCFA for administrative approval		
COA #7		PA3.3 Builer "B" Map COAs	Cond. #7	Prior to recordation of the final tract map			MANEUVERABILITY EASEMENT	Prior to recordation of the final tract map, the subdivider shall demonstrate that all necessary ingress/egress easements for vehicle maneuverability within motor courts/alleyways are identified on the final map subject to the satisfaction of the Planning Manager. The easement shall prohibit property owners from installing any improvements within the easement area or interfering with the use or maintenance of the easement.	Director, PDS, Director, OC Planning	Submit a copy of the proposed Tract map to OCFA for administrative approval		

Item No.	Cross Reference Column	Source	Condition, Mitigation, Public Benefit or Entitlement Provision	Timing	Subject	Keywords	Title	Requirements or Entitlement Provisions	Reviewing / Approving Authority (Advisory Agency in Parentheses)	Form of Compliance	Guidance for Compliance	Area Application
b. Prior to Approval of Site Development Permit												
109		EIR 589	MM 4.7-3	Prior to approval of Master Area Plan or Subarea Plan Site Development Permit	Air Quality	Shade trees, evaporative emissions	Incorporate Shade Trees into Parking Lot Design	With the submittal of each Master Area Plan, the project applicant shall identify how shade trees can be incorporated into parking lot designs (to reduce evaporative emissions from parked vehicles); where shade trees can be sited (to reduce summer cooling needs); and how shade trees would be incorporated into bicycle and pedestrian path design. <i>[Note: for the purposes of clarification, the timing of this requirement should be interpreted to read as follows: Prior to approval of each applicable Site Development permit, the project applicant shall ...]</i>	Director, PDS Director, OC Planning	Submittal of satisfactory landscape plans (precise, not general landscape plan at SDP level)		Each PA
110	111 (MM 4.7-3)	EIR 589	MM 4.7-3 (cont.)	Prior to approval of Master Area Plan or Subarea Plan Site Development Permit	Air Quality	Light-colored roof materials	Use Light-Colored Roof Materials to Reflect Heat (Item Nos. 110-111)	As a part of each Master Area Plan, the applicant shall identify how the use of light-colored roof materials and paint to reflect heat to the extent feasible has been incorporated into the design plans. <i>[Note: for the purposes of clarification, the timing of this requirement should be interpreted to read as follows: Prior to approval of each applicable Site Development permit, the project applicant shall ...]</i>	Director, PDS Director, OC Planning	Issuance of Building Permit (Evidence of reflection of materials)		Each PA
c. Prior to Issuance of Grading Permits												
521		EIR 589	SC 4.4-1	Prior to the issuance of a grading permit	Geology and Soils:		Geology and Soils:	Prior to the issuance of a grading permit, the applicant shall submit a geotechnical report to the Manager of Subdivision Manager OC Planned Communities and Grading, for approval. The report shall meet the requirements outlined in the County of Orange Grading Code and Manual. (County Standard Condition G01)	County of Orange Director of Planning & Development Services, Director, OC Planning	Submittal of satisfactory geotechnical report		Each PA
522		EIR 589	SC 4.4-2	Prior to the issuance of a grading permit	Geology and Soils (cont.):		Geology and Soils (cont.):	Prior to the issuance of any grading permits, the Manager of Subdivision and Grading shall review the grading plan for conformance with the grading shown on the approved tentative map. If the applicant submits a grading plan which the Manager of Subdivision and Grading Manager OC Planned Communities determines to show a significant deviation from the grading shown on the approved tentative map, specifically with regard to slope heights, slope ratios, pad elevations or configurations, the Subdivision Committee shall review the plan for a finding of substantial conformance. (County Standard Condition G02)	County of Orange Director of Planning & Development Services, Director, OC Planning	Approval of grading plan demonstrating submittal conformance with the grading shown on the approved TTM		Each PA

Item No.	Cross Reference Column	Source	Condition, Mitigation, Public Benefit or Entitlement Provision	Timing	Subject	Keywords	Title	Requirements or Entitlement Provisions	Reviewing / Approving Authority (Advisory Agency in Parentheses)	Form of Compliance	Guidance for Compliance	Area Application
523		EIR 589	SC 4.4-2 (cont.)	Prior to the issuance of a grading permit	Geology and Soils (cont.):		Geology and Soils (cont.):	If the Subdivision Committee fails to make such a finding, the applicant shall process a revised tentative map; or, if a final map has been recorded, the applicant shall process a new tentative map or a site development permit application per Orange County Zoning Code Sections 7-9-139 and 7-9-150. Additionally, the applicant shall process a new environmental assessment for determination by the decision making entity. (County Standard Condition G02)	Subdivision Committee review for substantial conformance, if required	Process new subdivision, if necessary		Each PA
524		EIR 589	SC 4.4-3	Prior to the recordation of a subdivision map or prior to issuance of a Grading Permit, whichever comes first	Geology and Soils (cont.):		Geology and Soils (cont.):	Prior to the recordation of a subdivision map or prior to the issuance of any grading permit, whichever comes first, and if determined necessary by the County of Orange Manager, Subdivision and Grading, the applicant shall record a letter of consent from the affected property owners permitting off-site grading, cross lot drainage, drainage diversions and/or unnatural concentrations. The applicant shall obtain approval of the form of the letter of consent from the Manager, Subdivision and Grading Services before recordation of the letter. (County Standard Condition G04)	County of Orange Director of Planning & Development Services, Director, OC Planning	Recordation of a letter of consent from affected property owners if determined necessary by County of Orange Director of Planning & Development Services		Each PA
525		EIR 589	SC 4.4-4	Prior to the issuance of grading permits	Geology and Soils (cont.):		Geology and Soils (cont.):	Prior to issuance of grading permits, the Manager of Subdivision and Grading- Manager OC Planned Communities shall determine that the proposed grading is consistent with the grading depicted within the approved planning application. (County Standard Condition G09)	County of Orange Director of Planning & Development Services, Director, OC Planning	Approval of grading plan		Each PA
527		EIR 589	SC 4.5-1	Prior to recordation of a Subdivision Map or issuance of a Grading Permit, whichever comes first	Drainage Study:		Drainage Study:	Prior to the recordation of a subdivision map (except maps for financing and conveyance purposes only) or prior to the issuance of any grading permits, whichever comes first, the following drainage studies shall be submitted to and approved by the Manager, Subdivision and Grading: (County Standard Condition D01a)	County of Orange Director of Planning & Development Services, Director, OC Planning	Submittal of satisfactory of drainage study		Each PA

Item No.	Cross Reference Column	Source	Condition, Mitigation, Public Benefit or Entitlement Provision	Timing	Subject	Keywords	Title	Requirements or Entitlement Provisions	Reviewing / Approving Authority (Advisory Agency in Parentheses)	Form of Compliance	Guidance for Compliance	Area Application
527.1		EIR 589	SC 4.5-1 (cont.)	See above	Drainage Study (cont.):		Drainage Study (cont.):	A. A drainage study of the project including diversions, off-site areas that drain onto and/or through the project, and justification of any diversions; and B. When applicable, a drainage study evidencing that proposed drainage patterns will not overload existing storm drains; and C. Detailed drainage studies indicating how the project grading, in conjunction with the drainage conveyance systems including applicable swales, channels, street flows, catch basins, storm drains, and flood water retarding, will allow building pads to be safe from inundation from rainfall runoff which may be expected from all storms up to and including the theoretical 100-year flood. (County Standard Condition D01a)	See above	See above		Each PA
528		EIR 589	SC 4.5-2	Prior to recordation of a Subdivision Map or Issuance of a Grading Permit, whichever comes first	Drainage Improvements:		Drainage Improvements:	A. Prior to the recordation of a subdivision map (except maps for financing and conveyance purposes only) or prior to the issuance of any grading permits, whichever comes first, the applicant shall in a manner meeting the approval of the Manager, Subdivision and Grading: (County Standard Condition D02a)	County of Orange Director of Planning & Development Services, Director, OC Planning	Approval of storm drain drainage plans and offer(s) of dedication, if necessary		Each PA
528.1		EIR 589	SC 4.5-2 (cont.)	See above	Drainage Improvements (cont.):		Drainage Improvements (cont.):	1) Design provisions for surface drainage; 2) Design all necessary storm drain facilities extending to a satisfactory point of disposal for the proper control and disposal of storm runoff; and 3) Dedicate the associated easements to the County of Orange, if determined necessary. (County Standard Condition D02a)	See above	See above		Each PA

Item No.	Cross Reference Column	Source	Condition, Mitigation, Public Benefit or Entitlement Provision	Timing	Subject	Keywords	Title	Requirements or Entitlement Provisions	Reviewing / Approving Authority (Advisory Agency in Parentheses)	Form of Compliance	Guidance for Compliance	Area Application
530		EIR 589	SC 4.5-3	Prior to the issuance of Grading Permits	Drainage Improvements (cont.):		Drainage Improvements (cont.):	A. Prior to the issuance of any grading permits, the applicant shall in a manner meeting the approval of the Manager, Subdivision and Grading: (County Standard Condition D02b)	County of Orange Director of Planning & Development Services, Director, OC Planning	Submittal of satisfactory drainage plans		Each PA
530.1		EIR 589	SC 4.5-3 (cont.)	See above	Drainage Improvements (cont.):		Drainage Improvements (cont.):	1) Design provisions for surface drainage; and 2) Design all necessary storm drain facilities extending to a satisfactory point of disposal for the proper control and disposal of storm runoff; and 3) Dedicate the associated easements to the County of Orange, if determined necessary. (County Standard Condition D02b)	See above	See above		Each PA
537		EIR 589	SC 4.5-8	Prior to the recordation of a Subdivision Map or the issuance of any Grading or Building Permit, whichever comes first	Water Quality Management Plan:		Water Quality Management Plan:	Prior to the recordation of any final subdivision map (except those maps for financing or conveyance purposes only) or the issuance of any grading or building permit (whichever comes first), the applicant shall submit for review and approval by the Manager, Inspection Services Division, a Water Quality Management Plan (WQMP) specifically identifying Best Management Practices (BMPs) that will be used onsite to control predictable pollutant runoff. This WQMP shall identify, at a minimum, the routine structural and non-structural measures specified in the current Drainage Area Management Plan (DAMP). The WQMP may include one or more of the following: (County Standard Condition WQ01)	County of Orange Director of Planning & Development Services, Director, OC Planning	Submittal of satisfactory Water Quality Management Plan		Each PA

RANCH PLAN REGULATION COMPLIANCE MATRIX GUIDANCE DOCUMENT

Appendix C

PA 3.4 BUILDER "B" MAP REQUIREMENTS SORTED BY MILESTONE

Item No.	Cross Reference Column	Source	Condition, Mitigation, Public Benefit or Entitlement Provision	Timing	Subject	Keywords	Title	Requirements or Entitlement Provisions	Reviewing / Approving Authority (Advisory Agency in Parentheses)	Form of Compliance	Guidance for Compliance	Area Application
537.1		EIR 589	SC 4.5-8 (cont.)	See above	Water Quality Management Plan (cont.):		Water Quality Management Plan (cont.):	<ul style="list-style-type: none"> • Discuss regional water quality and/or watershed programs (if available for the project); • Address Site Design BMPs (as applicable) such as minimizing impervious areas, maximizing permeability, minimizing directly connected impervious areas, creating reduced or "zero discharge" areas, and conserving natural areas; • Include the applicable Routine Source Control BMPs as defined in the DAMP. (County Standard Condition WQ01) 	See above	See above		Each PA
538		EIR 589	SC 4.5-8 (cont.)	See above	Water Quality Management Plan (cont.):		Water Quality Management Plan (cont.):	Demonstrate how surface runoff and subsurface drainage shall be managed and directed to the nearest acceptable drainage facility (as applicable), via sump pumps if necessary. (Standard Condition of Approval, WQ03)	See above	See above		Each PA
540		EIR 589	SC 4.5-10	Prior to the issuance of any Grading or Building Permits	Stormwater Pollution Prevention Plan.		Stormwater Pollution Prevention Plan.	<p>Prior to the issuance of any grading or building permits, the applicant shall demonstrate compliance under California's General Permit for Stormwater Discharges Associated with Construction Activity by providing a copy of the Notice of Intent (NOI) submitted to the State Water Resources Control Board and a copy of the subsequent notification of the issuance of a Waste Discharge Identification (WDID) Number or other proof of filing in a manner meeting the satisfaction of the Manager, Building Permit Services. Projects subject to this requirement shall prepare and implement a Stormwater Pollution Prevention Plan (SWPPP). A copy of the current SWPPP shall be kept at the project site and be available for County review on request. (County Standard Condition WQ04)</p>	County of Orange Manager of Building Inspection Manager, OC Inspection Division (Regional Water Quality Control Board)	Provision of Notice of Intent and verification of a copy of the Storm Water Pollution Prevention Plan (SWPPP); at the project site		Each PA

Item No.	Cross Reference Column	Source	Condition, Mitigation, Public Benefit or Entitlement Provision	Timing	Subject	Keywords	Title	Requirements or Entitlement Provisions	Reviewing / Approving Authority (Advisory Agency in Parentheses)	Form of Compliance	Guidance for Compliance	Area Application
541		EIR 589	SC 4.5-11	Prior to the issuance of any Grading or Building Permits	Erosion and Sediment Control Plan.		Erosion and Sediment Control Plan.	Prior to the issuance of any grading or building permit, the applicant shall submit a Erosion and Sediment Control Plan (ESCP) in a manner meeting approval of the Manager, Building Permit Services, to demonstrate compliance with local and state water quality regulations for grading and construction activities. The ESCP shall identify how all construction materials, wastes, grading or demolition debris, and stockpiles of soil, aggregates, soil amendments, etc. shall be properly covered, stored, and secured to prevent transport into local drainages or coastal waters by wind, rain, tracking, tidal erosion or dispersion. The ESCP shall also describe how the applicant will ensure that all BMPs will be maintained during construction of any future public right-of-ways. A copy of the current ESCP shall be kept at the project site and be available for County review on request. (County Standard Condition WQ05)	County of Orange Manager of Building Permits, Manager, Permit Services (Building Plan Check)	Submittal of satisfactory Erosion and Sediment Control Plan (ESCP); verification of copy of ESCP at project site		Each PA
548		EIR 589	SC 4.6-6	Prior to the issuance of Grading Permits	Sight Distance:		Sight Distance:	Prior to the issuance of any grading permits, the applicant shall provide adequate sight distance per Standard Plan 1117 at all street intersections, in a manner meeting the approval of the Manager, Subdivision and Grading. The applicant shall make all necessary revisions to the plan to meet the sight distance requirement such as removing slopes or other encroachments from the limited use area in a manner meeting the approval of the Manager, Subdivision and Grading Services. (Standard Condition of Approval T07)	County of Orange Director of Planning & Development Services, Director, OC Planning	Approved grading plans verifying adequate sight distance		Each PA
555		EIR 589	SC 4.7-1	Prior to the issuance of a grading permit	Fugitive Dust:		Fugitive Dust:	All construction contractors shall comply with South Coast Air Quality Management District (SCAQMD) regulations, including Rule 403, Fugitive Dust, and Rule 402, Nuisance. All grading (regardless of acreage) shall apply best available control measures for fugitive dust in accordance with Rule 403. To ensure that the project is in full compliance with applicable SCAQMD dust regulations and that there is no nuisance impact off the site, the contractor would implement each of the following:	County of Orange Director of Planning & Development Services, Director, OC Planning	Verification of compliance with Rule 403 and Rule 402		Each PA

Item No.	Cross Reference Column	Source	Condition, Mitigation, Public Benefit or Entitlement Provision	Timing	Subject	Keywords	Title	Requirements or Entitlement Provisions	Reviewing / Approving Authority (Advisory Agency in Parentheses)	Form of Compliance	Guidance for Compliance	Area Application
555.1		EIR 589	SC 4.7-1 (cont.)	See above	Fugitive Dust (cont.):		Fugitive Dust (cont.):	a. Moist soil not more than 15 minutes prior to moving soil or conduct whatever watering is necessary to prevent visible dust emissions from traveling more than 100 feet in any direction.	See above	See above		Each PA
555.2		EIR 589	SC 4.7-1 (cont.)	See above	Fugitive Dust (cont.):		Fugitive Dust (cont.):	b. Apply chemical stabilizers to disturbed surface areas (i.e., completed grading areas) within five days of completing grading or apply dust suppressants or vegetation sufficient to maintain a stabilized surface.	See above	See above		Each PA
555.3		EIR 589	SC 4.7-1 (cont.)	See above	Fugitive Dust (cont.):		Fugitive Dust (cont.):	c. Water excavated soil piles hourly or cover with temporary coverings.	See above	See above		Each PA
555.4		EIR 589	SC 4.7-1 (cont.)	See above	Fugitive Dust (cont.):		Fugitive Dust (cont.):	d. Water exposed surfaces at least twice a day under calm conditions. Water as often as needed on windy days when winds are less than 25 miles per day or during very dry weather in order to maintain a surface crust and prevent the release of visible emissions from the construction site.	See above	See above		Each PA
555.5		EIR 589	SC 4.7-1 (cont.)	See above	Fugitive Dust (cont.):		Fugitive Dust (cont.):	e. Wash mud-covered tires and under-carriages of trucks leaving construction sites.	See above	See above		Each PA
555.5		EIR 589	SC 4.7-1 (cont.)	See above	Fugitive Dust (cont.):		Fugitive Dust (cont.):	f. Provide for street sweeping, as needed, on adjacent roadways to remove dirt dropped by construction vehicles or mud, which would otherwise be carried off by trucks departing from project sites.	See above	See above		Each PA
556		EIR 589	SC 4.7-2	Prior to issuance of a grading permit	Construction - ROC and NOX Emissions:		Construction - ROC and NOX Emissions:	The applicant shall comply with the following measures, as feasible, to reduce NO _x and ROC from heavy equipment.	County of Orange Director of Planning & Development Services, Director, OC Planning	Place as general notes on approved grading plan		Each PA
556.1		EIR 589	SC 4.7-2 (cont.)	See above	Construction Emissions:		Construction Emissions:	a. Turn equipment off when not in use for more than five minutes.	See above	See above		Each PA
556.2		EIR 589	SC 4.7-2 (cont.)	See above	Construction Emissions (cont.):		Construction Emissions (cont.):	b. Maintain equipment engines in good condition and in proper tune as per manufacturers' specifications.	See above	See above		Each PA
556.3		EIR 589	SC 4.7-2 (cont.)	See above	Construction Emissions (cont.):		Construction Emissions (cont.):	c. Lengthen the construction period during smog season (May through October) to minimize the number of vehicles and equipment operating at the same time.	See above	See above		Each PA

Item No.	Cross Reference Column	Source	Condition, Mitigation, Public Benefit or Entitlement Provision	Timing	Subject	Keywords	Title	Requirements or Entitlement Provisions	Reviewing / Approving Authority (Advisory Agency in Parentheses)	Form of Compliance	Guidance for Compliance	Area Application
557		EIR 589	SC 4.8-1	Prior to the issuance of grading permits	Hours of Construction:		Hours of Construction:	During construction, the project applicant shall ensure that all noise generating activities be limited to the hours of 7 a.m. to 8 p.m. on weekdays and Saturdays. No noise generating activities shall occur on Sundays and holidays in accordance with the County of Orange Noise Ordinance.	County of Orange Director of Planning & Development Services, Director, OC Planning	General note on approved grading plan		Each PA
558		EIR 589	SC 4.8-2	Prior to the issuance of grading permits	Construction Noise:		Construction Noise:	A. Prior to the issuance of any grading permits, the project proponent shall produce evidence acceptable to the Manager, Building Permits Services, that: (County Standard Condition N10)	County of Orange Director of Planning & Development Services, Director, OC Planning	General note on approved grading plan		Each PA
558.1		EIR 589	SC 4.8-2 (cont.)	See above	Construction Noise (cont.):		Construction Noise (cont.):	(1) All construction vehicles or equipment, fixed or mobile, operated within 1,000' of a dwelling shall be equipped with properly operating and maintained mufflers. (County Standard Condition N10)	See above	See above		Each PA
558.2		EIR 589	SC 4.8-2 (cont.)	See above	Construction Noise (cont.):		Construction Noise (cont.):	(2) All operations shall comply with Orange County Codified Ordinance Division 6 (Noise Control). (County Standard Condition N10)	See above	See above		Each PA
558.3		EIR 589	SC 4.8-2 (cont.)	See above	Construction Noise (cont.):		Construction Noise (cont.):	(3) Stockpiling and/or vehicle staging areas shall be located as far as practicable from dwellings. (County Standard Condition N10)	See above	See above		Each PA
558.4		EIR 589	SC 4.8-2 (cont.)	See above	Construction Noise (cont.):		Construction Noise (cont.):	B. Notations in the above format, appropriately numbered and included with other notations on the front sheet of the project's permitted grading plans, will be considered as adequate evidence of compliance with this condition. (County Standard Condition N10)	See above	See above		Each PA
559		EIR 589	SC 4.8-3	See below	Sound Attenuation:		Sound Attenuation:	The applicant shall sound attenuate all residential lots and dwellings against present and projected noise (which shall be the sum of all noise impacting the project) so that the composite interior standard of 45 dBA CNEL for habitable rooms and a source specific exterior standard of 65 dBA CNEL for outdoor living areas is not exceeded. The applicant shall provide a report prepared by a County-certified acoustical consultant, which demonstrates that these standards will be satisfied in a manner consistent with Zoning Code Section 7-9-137.5, as follows: (County Standard Condition N01)	County of Orange Director of Planning & Development Services and County of Orange Manager of Building Permits Services, Director, OC Planning and Manager, Permit Services (Building Plan Check)	Submittal of satisfactory acoustical analysis	Staff may determine that no attenuation is necessary, and no action is required (as occurred in PA1). In such a case a "not applicable" memo is to be prepared. Applicant and County staff to address AC units in side yards as soon as possible.	Each PA

RANCH PLAN REGULATION COMPLIANCE MATRIX GUIDANCE DOCUMENT

Appendix C

PA 3.4 BUILDER "B" MAP REQUIREMENTS SORTED BY MILESTONE

Item No.	Cross Reference Column	Source	Condition, Mitigation, Public Benefit or Entitlement Provision	Timing	Subject	Keywords	Title	Requirements or Entitlement Provisions	Reviewing / Approving Authority (Advisory Agency in Parentheses)	Form of Compliance	Guidance for Compliance	Area Application
559.1		EIR 589	SC 4.8-3 (cont.)	Prior to the recordation of a subdivision map or prior to the issuance of grading permits	Sound Attenuation (cont.):		Sound Attenuation (cont.):	a. Prior to the recordation of a subdivision map or prior to the issuance of grading permits, as determined by the Manager, Building Permits Services, the applicant shall submit an acoustical analysis report to the Manager, Building Permits Services, for approval. The report shall describe in detail the exterior noise environment and preliminary mitigation measures. Acoustical design features to achieve interior noise standards may be included in the report in which case it may also satisfy Condition B below. (County Standard Condition N01)	See above	See above		Each PA
567		EIR 589	SC 4.10-2	Prior to the issuance of precise grading permits	Private Area Landscaping:		Private Area Landscaping:	a. Prior to the issuance of precise grading permits, the applicant shall prepare a detailed landscape plan for privately maintained common areas which shall be reviewed and approved by the Manager, Subdivision and Grading. The plan shall be certified by a licensed landscape architect or a licensed landscape contractor, as required, as taking into account the approved preliminary landscape plan (if any), County Standard Plans for landscape areas, adopted plant palette guides, applicable scenic and specific plan requirements, Water Conservation Measures contained in Board Resolution 90-487 (Water Conservation Measures), and Board Resolution 90-1341 (Water Conservation Implementation Plan). (County Standard Condition LA02b)	County of Orange Director of Planning & Development Services, Director, OC Planning	Approved detailed landscape plan for privately maintained common areas		Each PA
571	172-176 (MM 4.11-3)	EIR 589	SC 4.11-1	Prior to the issuance of any grading permits	Archaeology Grading Observation and Salvage:		Archaeology Grading Observation and Salvage:	Prior to the issuance of any grading permit, the applicant shall provide written evidence to the County of Orange Manager, Subdivision and Grading, that applicant has retained a County-certified archaeologist to observe grading activities and salvage and catalogue archaeological resources as necessary. The archaeologist shall be present at the pre-grade conference; shall establish procedures for archaeological resource surveillance; and shall establish, in cooperation with the applicant, procedures for temporarily halting or redirecting work to permit the sampling, identification, and evaluation of the artifacts as appropriate. If the archaeological resources are found to be significant, the archaeological observer shall determine appropriate actions, in cooperation with the project applicant, for exploration and/or salvage. (County Standard Condition A04)	County of Orange Manager, Harbors, Beaches & Parks, HBP/Coastal and Historical Facilities — OC Public Works/OC Planning*	Written evidence that a County-certified archaeologist has been retained to observe grading and salvage, and to catalogue archaeological resources	If prior to rough grade (GA permit) applicant has obtained archaeological clearance, no additional review or clearance required if precise grading (GB) permit is in compliance with GA permit.	Each PA

RANCH PLAN REGULATION COMPLIANCE MATRIX GUIDANCE DOCUMENT

Appendix C

PA 3.4 BUILDER "B" MAP REQUIREMENTS SORTED BY MILESTONE

Item No.	Cross Reference Column	Source	Condition, Mitigation, Public Benefit or Entitlement Provision	Timing	Subject	Keywords	Title	Requirements or Entitlement Provisions	Reviewing / Approving Authority (Advisory Agency in Parentheses)	Form of Compliance	Guidance for Compliance	Area Application
574		EIR 589	SC 4.11-2	Prior to the issuance of any grading permits	Paleontology Resource Surveillance:		Paleontology Resource Surveillance:	Prior to the issuance of any grading permit, the project contractor shall provide written evidence to the Manager, Subdivision and Grading, that contractor has retained a County certified paleontologist to observe grading activities and salvage and catalogue fossils as necessary. The paleontologist shall be present at the pre-grade conference, shall establish procedures for paleontological resources surveillance, and shall establish, in cooperation with the contractor, procedures for temporarily halting or redirecting work to permit sampling, identification, and evaluation of the fossils. If the paleontological resources are found to be significant, the paleontologist shall determine appropriate actions, in cooperation with the contractor, which ensure proper exploration and/or salvage. (County Standard Condition A07)	County of Orange Manager, Harbors, Beaches & Parks, HBP/Coastal and Historical Facilities OC Public Works/OC Planning*	Written evidence that a County-certified archaeologist has been retained to observe grading and salvage, and to catalogue fossils as necessary		Each PA
589		EIR 589	SC 4.14-2	Prior to issuance of a grading and/or building permit	Hazardous Materials:		Hazardous Materials:	Prior to the issuance of a grading or building permit, the contractor shall submit to the Fire Chief a list of all hazardous, flammable and combustible liquids, solids or gases to be stored, used or handled on site. These materials shall be classified according to the Uniform Fire Code and a document submitted to the Fire Chief with a summary sheet listing the totals for storage and use for each hazard class. (County Standard Condition FPC11A)	County of Orange Director of Planning & Development Services Director, OC Planning (OCFA)	Submittal of Hazardous Materials Assessment and Disclosure Statement		Each PA
616		Fire Prot. Prog.	Cond. 3.d.	Prior to the issuance of a GB precise grading permit	Precise Fuel Mod:		Precise Fuel Mod:	d) Prior to the issuance of a GB precise grading permit, the applicant shall provide the Manager, PDS Subdivision and Infrastructure Manager OC Planned Communities , with a clearance from OCFA indicating their review and approval of a Precise Fuel Modification Plan per RPFPP Section C.3.	Director, PDS Director, OC Planning	Provide the Manager, PDS Subdivision and Infrastructure Manager OC Planned Communities with a clearance from OCFA demonstrating approval of a Conceptual Fuel Modification Plan		

* In Coordination with Manager, Land Development

Item No.	Cross Reference Column	Source	Condition, Mitigation, Public Benefit or Entitlement Provision	Timing	Subject	Keywords	Title	Requirements or Entitlement Provisions	Reviewing / Approving Authority (Advisory Agency in Parentheses)	Form of Compliance	Guidance for Compliance	Area Application
COA# 2		PA3.3 Builer "B" Map COAs		Prior to the issuance of any grading or building permits	WQMP			Prior to the issuance of any grading or building permits, the applicant shall submit for review and approval by the Manager, Permit Services, a Water Quality Management Plan (WQMP) specifically identifying Best Management Practices (BMPs) that will be used onsite to control predictable pollutant runoff. The applicant shall utilize the Orange County Drainage Area Management Plan (DAMP), Model WQMP, and Technical Guidance Manual for reference, and the County's WQMP template for submittal.	County of Orange Manager, Building Inspection Services, Manager, OC Inspection Division			Each PA
COA# 2 (cont.)		PA3.3 Builer "B" Map COAs		See above	WQMP			<p>This WQMP shall include the following:</p> <ul style="list-style-type: none"> - Detailed site and project description - Potential stormwater pollutants - Post-development drainage characteristics - Low Impact Development (LID) BMP selection and analysis - Structural and Non-Structural source control BMPs - Site design and drainage plan (BMP Exhibit) - GIS coordinates for all LID and Treatment Control BMPs - Operation and Maintenance (O&M) Plan that (1) describes the long-term operation and maintenance requirements for BMPs identified in the BMP Exhibit; (2) identifies the entity that will be responsible for long-term operation and maintenance of the referenced BMPs; and (3) describes the mechanism for funding the long-term operation and maintenance of the referenced BMPs <p>The BMP Exhibit from the approved WQMP shall be included as a sheet in all plan sets submitted for plan check and all BMPs shall be depicted on these plans. Grading and building plans must be consistent with the approved BMP exhibit.</p>	County of Orange Manager, Building Inspection Services, Manager, OC Inspection Division			Each PA

Item No.	Cross Reference Column	Source	Condition, Mitigation, Public Benefit or Entitlement Provision	Timing	Subject	Keywords	Title	Requirements or Entitlement Provisions	Reviewing / Approving Authority (Advisory Agency in Parentheses)	Form of Compliance	Guidance for Compliance	Area Application
d. Prior to Precise Fuel Modification Plans												
138	137 and 139 (EIR 589, MM 4.9-27) 514 (ROSA Exhibit G)	EIR 589	MM 4.9-27 (cont.)	Prior to the approval of Precise Fuel Modification Plans	Biological Resources	California Exotic Pest Plant Council, OCFA Fuel Modification Plant List	Invasive Plants and Fuel Modification	a. Prior to issuance of fuel modification plan approvals, the County of Orange shall verify that: 1) plants identified by the California Exotic Pest Plant Council as an invasive risk in Southern California are not included in plans for fuel management zones adjacent to the RMV Open Space and. 2) the plant palette for fuel management zones adjacent to RMV Open Space is limited to those species listed on the Orange County Fire Authority Fuel Modification Plant List.	Director, PDS - Director, OC Planning (OCFA)	Verification of authorized plant materials	Signature of Landscape Architect on approved Precise Fuel Modification Plan certifying plant palette: (a) complies with current OCFA plant list, and (b) does not include plants listed on the current invasive species list.	Each PA
e. Prior to Issuance of Building Permit												
111	110 (MM 4.7-3)	EIR 589	MM 4.7-3 (cont.)	Prior to issuance of building permits	Air Quality	Light-colored roof materials	Use Light-Colored Roof Materials to Reflect Heat (Item Nos. 110-111)	Prior to issuance of building permits, the applicant shall identify how the use of light-colored roof materials and paint to reflect heat to the extent feasible has been incorporated into the design plans.	Director, PDS - Director, OC Planning	Issuance of Building Permit (Evidence of reflection of heat through home design)	Sustainability Issue	Each PA
140	141 (MM 4.9-28) 515 (ROSA Exhibit G)	EIR 589	MM 4.9-28	Prior to the issuance of Building permits on streets for tracts with public street lighting adjacent to RMV Open Space habitat areas	Biological Resources	Open Space habitat, light shields	Streetlight Shielding Adjacent to Open Space	Lighting shall be shielded or directed away from RMV Open Space habitat areas through the use of low-sodium or similar intensity lights, light shields, native shrubs, berms or other shielding methods.	Director, PDS - Director, OC Planning	Preparation of a lighting plan	Preparation of street improvement plans for public streets that detail how street lighting is to be directed away from RMV Open Space areas	Each Applicable PA
206		EIR 589	MM 4.15-5	Prior to issuance of residential building permits (excluding age-qualified units)	Public Services and Facilities	California Government Code Section 65995	CUSD Agreement	Prior to issuance of any residential building permit, excluding senior housing, the applicant shall enter into an agreement with CUSD regarding the development of future facilities and payment of costs. The agreement shall, at a minimum, provide for the payment of fees pursuant to California Government Code Section 65995. If fees are paid, the amount of fees to be paid will be determined based on the established State formula for determining construction costs. Applicable fees shall be paid prior to the issuance of each building permit.	Capistrano Unified School District (CUSD)	Negotiate and execute Mitigation Agreement regarding future school facilities and payment of costs		PC-Wide
526		EIR 589	SC 4.4-5	Prior to the issuance of building permits	Geology and Soils (cont.):		Geology and Soils (cont.):	The proposed development shall be designed in compliance with the Uniform Building Code (UBC), accepted industry standards, and the County's earthquake safety Municipal Code requirements.	County of Orange Director of Planning & Development Services, Director, OC Planning	Verification of design development compliance with the UBC and Municipal Code requirements		Each PA

Item No.	Cross Reference Column	Source	Condition, Mitigation, Public Benefit or Entitlement Provision	Timing	Subject	Keywords	Title	Requirements or Entitlement Provisions	Reviewing / Approving Authority (Advisory Agency in Parentheses)	Form of Compliance	Guidance for Compliance	Area Application
537		EIR 589	SC 4.5-8	Prior to the recordation of a Subdivision Map or the issuance of any Grading or Building Permit, whichever comes first	Water Quality Management Plan:		Water Quality Management Plan:	Prior to the recordation of any final subdivision map (except those maps for financing or conveyance purposes only) or the issuance of any grading or building permit (whichever comes first), the applicant shall submit for review and approval by the Manager, Inspection Services Division, a Water Quality Management Plan (WQMP) specifically identifying Best Management Practices (BMPs) that will be used onsite to control predictable pollutant runoff. This WQMP shall identify, at a minimum, the routine structural and non-structural measures specified in the current Drainage Area Management Plan (DAMP). The WQMP may include one or more of the following: (County Standard Condition WQ01)	County of Orange Director of Planning & Development Services, Director, OC Planning	Submittal of satisfactory Water Quality Management Plan		Each PA
537.1		EIR 589	SC 4.5-8 (cont.)	See above	Water Quality Management Plan (cont.):		Water Quality Management Plan (cont.):	<ul style="list-style-type: none"> • Discuss regional water quality and/or watershed programs (if available for the project); • Address Site Design BMPs (as applicable) such as minimizing impervious areas, maximizing permeability, minimizing directly connected impervious areas, creating reduced or "zero discharge" areas, and conserving natural areas; • Include the applicable Routine Source Control BMPs as defined in the DAMP. (County Standard Condition WQ01) 	See above	See above		Each PA
538		EIR 589	SC 4.5-8 (cont.)	See above	Water Quality Management Plan (cont.):		Water Quality Management Plan (cont.):	Demonstrate how surface runoff and subsurface drainage shall be managed and directed to the nearest acceptable drainage facility (as applicable), via sump pumps if necessary. (Standard Condition of Approval, WQ03)	See above	See above		Each PA
540		EIR 589	SC 4.5-10	Prior to the issuance of any Grading or Building Permits	Stormwater Pollution Prevention Plan.		Stormwater Pollution Prevention Plan.	Prior to the issuance of any grading or building permits, the applicant shall demonstrate compliance under California's General Permit for Stormwater Discharges Associated with Construction Activity by providing a copy of the Notice of Intent (NOI) submitted to the State Water Resources Control Board and a copy of the subsequent notification of the issuance of a Waste Discharge Identification (WDID) Number or other proof of filing in a manner meeting the satisfaction of the Manager, Building Permit Services. Projects subject to this requirement shall prepare and implement a Stormwater Pollution Prevention Plan (SWPPP). A copy of the current SWPPP shall be kept at the project site and be available for County review on request. (County Standard Condition WQ04)	County of Orange Manager of Building Inspection Manager, OC Inspection Division (Regional Water Quality Control Board)	Provision of Notice of Intent and verification of a copy of the Storm Water Pollution Prevention Plan (SWPPP); at the project site		Each PA

RANCH PLAN REGULATION COMPLIANCE MATRIX GUIDANCE DOCUMENT

Appendix C

PA 3.4 BUILDER "B" MAP REQUIREMENTS SORTED BY MILESTONE

Item No.	Cross Reference Column	Source	Condition, Mitigation, Public Benefit or Entitlement Provision	Timing	Subject	Keywords	Title	Requirements or Entitlement Provisions	Reviewing / Approving Authority (Advisory Agency in Parentheses)	Form of Compliance	Guidance for Compliance	Area Application
541		EIR 589	SC 4.5-11	Prior to the issuance of any Grading or Building Permits	Erosion and Sediment Control Plan.		Erosion and Sediment Control Plan.	Prior to the issuance of any grading or building permit, the applicant shall submit a Erosion and Sediment Control Plan (ESCP) in a manner meeting approval of the Manager, Building Permit Services, to demonstrate compliance with local and state water quality regulations for grading and construction activities. The ESCP shall identify how all construction materials, wastes, grading or demolition debris, and stockpiles of soil, aggregates, soil amendments, etc. shall be properly covered, stored, and secured to prevent transport into local drainages or coastal waters by wind, rain, tracking, tidal erosion or dispersion. The ESCP shall also describe how the applicant will ensure that all BMPs will be maintained during construction of any future public right-of-ways. A copy of the current ESCP shall be kept at the project site and be available for County review on request. (County Standard Condition WQ05)	County of Orange Manager of Building Permits, Manager, Permit Services (Building Plan Check)	Submittal of satisfactory Erosion and Sediment Control Plan (ESCP); verification of copy of ESCP at project site		Each PA
547		EIR 589	SC 4.6-5	Prior to the issuance of Building Permits	Major Thoroughfare and Bridge Fee Programs:		Major Thoroughfare and Bridge Fee Programs:	Prior to the issuance of building permits, the applicant shall pay fees for the Major Thoroughfare and Bridge Fee Program for the Foothill/Eastern Transportation Corridor, in a manner meeting the approval of the Manager, Subdivision and Grading. (County Standard Condition T05)	County of Orange Director of Planning & Development Services, Director, OC Planning	Verification of payment of fees for the Major Thoroughfare and Bridge Fee Program		Each PA
550		EIR 589	SC 4.6-8	Prior to the recordation of a Subdivision Map or prior to the issuance of Building Permits, whichever occurs first	Internal Circulation:		Internal Circulation:	A. Prior to the recordation of a subdivision map or the issuance of any building permits, whichever occurs first, the subdivider shall provide plans and specifications meeting the approval of the Manager, Subdivision and Grading, for the design of the following improvements: (County Standard Condition T12)	County of Orange Director of Planning & Development Services,	Submittal of satisfactory street improvement plans		Each PA
550.1		EIR 589	SC 4.6-8 (cont.)	See above	Internal Circulation (cont.):		Internal Circulation (cont.):	1) Internal street common private drive system. (County Standard Condition T12)	See above	See above		Each PA
550.2		EIR 589	SC 4.6-8 (cont.)	See above	Internal Circulation (cont.):		Internal Circulation (cont.):	2) Entrance to the site to emphasize that the development is private by use of signs and other features. (Standard Condition of Approval T12)	See above	See above		Each PA

Item No.	Cross Reference Column	Source	Condition, Mitigation, Public Benefit or Entitlement Provision	Timing	Subject	Keywords	Title	Requirements or Entitlement Provisions	Reviewing / Approving Authority (Advisory Agency in Parentheses)	Form of Compliance	Guidance for Compliance	Area Application
550.4		EIR 589	SC 4.6-8 (cont.)	Prior to the issuance of Building Permits	Internal Circulation (cont.):		Internal Circulation (cont.):	C. Prior to the issuance of any building permits, the subdivider shall provide plans meeting the approval of the Manager, Subdivision & Grading, for the design of the internal pedestrian circulation system within the development. (County Standard Condition T12)	County of Orange Director of Planning & Development Services, Director, OC Planning	Submittal of satisfactory internal pedestrians circulation plans		Each PA
559.2		EIR 589	SC 4.8-3 (cont.)	Prior to the issuance of any building permits for residential construction	Sound Attenuation (cont.):		Sound Attenuation (cont.):	b. Prior to the issuance of any building permits for residential construction, the applicant shall submit an acoustical analysis report describing the acoustical design features of the structures required to satisfy the exterior and interior noise standards to the Manager, Building Permits Services, for approval along with satisfactory evidence which indicates that the sound attenuation measures specified in the approved acoustical report have been incorporated into the design of the project. (County Standard Condition N01)	County of Orange Director of Planning & Development Services and County of Orange Manager of Building Permits Services, Director, OC Planning, and Manager, Permit Services (Building Plan Check)	Submittal of satisfactory acoustical analysis		Each PA
559.3		EIR 589	SC 4.8-3 (cont.)	See above	Sound Attenuation (cont.):		Sound Attenuation (cont.):	c. Prior to the issuance of any building permits, the applicant shall show all freestanding acoustical barriers on the project's plot plan illustrating height, location and construction in a manner meeting the approval of the Manager, Building Permits Services. (County Standard Condition N01)	See above	See above		Each PA
564		EIR 589	SC 4.10-1	Prior to the issuance of building permits	Public Area Landscaping:		Public Area Landscaping:	The applicant shall install landscaping, equip for irrigation, and improvements on lots in accordance with an approved plan as stated below: (County Standard Condition LA01b)	County of Orange Director of Planning & Development Services in consultation with Manager, HBP, Director, OC Planning	Approved landscaping plan and irrigation plan		Each PA

Item No.	Cross Reference Column	Source	Condition, Mitigation, Public Benefit or Entitlement Provision	Timing	Subject	Keywords	Title	Requirements or Entitlement Provisions	Reviewing / Approving Authority (Advisory Agency in Parentheses)	Form of Compliance	Guidance for Compliance	Area Application
564.1		EIR 589	SC 4.10-1 (cont.)	See above	Public Area Landscaping:		Public Area Landscaping:	a. Detailed Plan—Prior to the issuance of any building permit(s), the applicant shall submit a detailed landscape plan showing the detailed irrigation and landscaping design to the Manager, Subdivision and Grading for approval, in consultation with the Manager HBP/Program Management. Detailed plans shall show the detailed irrigation and landscaping design and shall take into account the previously approved landscape plan for the Ranch Plan project, the County Standard Plans for landscape areas, adopted plant palette guides, applicable scenic and specific plan requirements, Water Conservation Measures contained in Board Resolution 90-487 (Water Conservation Measures), and Board Resolution 90-1341 (Water Conservation Implementation Plan). (County Standard Condition LA01b)	See above	See above		Each PA
570		EIR 589	SC 4.10-3	Prior to the issuance of building permits	Light and Glare:		Light and Glare:	Prior to issuance of any building permit, the applicant shall demonstrate that all exterior lighting has been designed and located so that all direct rays are confined to the property in a manner meeting the approval of the Manager, Building Permit. (County Standard Condition LG01)	County of Orange Manager of Building Permits, Manager, Permit Services (Building Plan Check)	Approved lighting study/plan	Low voltage lighting: landscape architect is the designer can sign off on the lighting. High voltage lighting: electrical engineer stamp required.	Each PA
589		EIR 589	SC 4.14-2	Prior to issuance of a grading and/or building permit	Hazardous Materials:		Hazardous Materials:	Prior to the issuance of a grading or building permit, the contractor shall submit to the Fire Chief a list of all hazardous, flammable and combustible liquids, solids or gases to be stored, used or handled on site. These materials shall be classified according to the Uniform Fire Code and a document submitted to the Fire Chief with a summary sheet listing the totals for storage and use for each hazard class. (County Standard Condition FPC11A)	County of Orange Director of Planning & Development Services, Director, OC Planning (OCFA)	Submittal of Hazardous Materials Assessment and Disclosure Statement		Each PA

Item No.	Cross Reference Column	Source	Condition, Mitigation, Public Benefit or Entitlement Provision	Timing	Subject	Keywords	Title	Requirements or Entitlement Provisions	Reviewing / Approving Authority (Advisory Agency in Parentheses)	Form of Compliance	Guidance for Compliance	Area Application
617		Fire Prot. Prog.	Cond. 3.e.	Prior to the issuance of a building permit for construction phases of Vesting Tentative Tract Maps adjoining fuel modification areas, and prior to the County of Orange allowing fuel tanks, generators and/or Lumber Drops	Vegetation Clearance:		Vegetation Clearance:	e) Prior to the issuance of a building permit for construction phases of Vesting Tentative Tract Maps adjoining fuel modification areas, and prior to the County of Orange allowing fuel tanks, generators and/or Lumber Drops (see Section E, Definitions) within the project site, the applicant shall provide the Manager, Building & Safety, with a clearance from OCFA indicating that vegetation has been cleared and maintained at a height of 8 inches or less, or that the appropriate fuel modification thinning and removal of plants from the OCFA Undesirable Plant List has been implemented.	Director, PDS, Director, OC Planning	Provide the Manager, Building & Safety, with a clearance from OCFA indicating that vegetation has been cleared and maintained		
COA# 3		PA3.3 Builer "B" Map COAs	Cond. #3	Prior to the issuance of a building permit			BEST MANAGEMENT PRACTICES	Prior to issuance of a building permit, the off-site regional Best Management Practices (BMPs) relied upon by this project (e.g., basins, swales, etc.) must be built and/or installed, and operational. The location and operation of these regional BMPs must be in compliance with the Final Project-Specific WQMP for the regional BMP(s). The location and operation of the regional BMP(s) must be demonstrated to the satisfaction of the Manager, Grading and Building Plan Check.	Director, PDS, Manager, Permit Services (Building Plan Check)			
COA# 6		PA3.3 Builer "B" Map COAs	Cond. #6	Prior to the issuance of a building permit			BUYER NOTIFICATION MAP	Prior to the issuance of any building permits for residential construction, the developer RMV Community Development, LLC, shall prepare a map denoting the existing and proposed land uses, arterial highways, and public facilities within the surrounding area for the approval of the Manager, OC Planning. The map content, display, and distribution shall be in accordance with the Buyer Notification Program guidelines listed in Board of Supervisors Resolution 82-1368 and as amended.	Director, PDS, Director, OC Planning			

Item No.	Cross Reference Column	Source	Condition, Mitigation, Public Benefit or Entitlement Provision	Timing	Subject	Keywords	Title	Requirements or Entitlement Provisions	Reviewing / Approving Authority (Advisory Agency in Parentheses)	Form of Compliance	Guidance for Compliance	Area Application
f. Prior to Combustible Construction												
609			Cond. 2.d.	Prior to initiation of combustible construction	A Map Fire Master Plan (cont.):		A Map Fire Master Plan (cont.):	d) Prior to initiation of combustible construction the following fire master plan improvements shall be verified by site inspection: • Emergency access • Water Supply	Director, PDS, Director, OC Planning	Site inspection		
g. During Construction												
197	196 (EIR 589, MM 4.14-13)	EIR 589	MM 4.14-13 (cont.)	During construction	Hazards and Hazardous Materials	Remedial measures	ESA Remedial Measures	If soil is encountered during site development that is suspected of being impacted by hazardous materials, work will be halted and site conditions will be evaluated by a qualified environmental professional. If requested by the qualified environmental professional, the results of the evaluation will be submitted to OCHCA and/or RWQCB, and the appropriate remedial measures will be implemented, as directed by OCHCA, RWQCB, or other applicable oversight agency, until all specified requirements of the oversight agencies are satisfied and a no-further-action status is attained.	Director, PDS, Director, OC Planning (Orange County Health Care Agency)	Stop work upon encountering condition; prepare evaluation and submit to OCHCA and/or RWQCB (as directed)		Each PA
h. Prior to Issuance of Certificates of Occupancy												
529		EIR 589	SC 4.5-2 (cont.)	Prior to recordation of a Subdivision Map or Issuance of a Certificate of Use and Occupancy, whichever comes first	Drainage Improvements (cont.):		Drainage Improvements (cont.):	B. Prior to the recordation of a subdivision map (except maps for financing and conveyance purposes only) or prior to the issuance of any certificates of use and occupancy, whichever occurs first, said improvements shall be constructed in a manner meeting the approval of the Manager, Construction. (County Standard Condition D02a)	County of Orange Manager of Inspection, Manager, OC Inspection Division	Verification of construction of drainage improvement		Each PA
531		EIR 589	SC 4.5-3 (cont.)	Prior to the issuance of Certificates of Use and Occupancy	Drainage Improvements (cont.):		Drainage Improvements (cont.):	B. Prior to the issuance of any certificates of use and occupancy, said improvements shall be constructed in a manner meeting the approval of the Manager, Construction. (County Standard Condition D02b)	County of Orange Manager of Inspection, Manager, OC Inspection Division	Verification of installation of drainage improvement		Each PA

Item No.	Cross Reference Column	Source	Condition, Mitigation, Public Benefit or Entitlement Provision	Timing	Subject	Keywords	Title	Requirements or Entitlement Provisions	Reviewing / Approving Authority (Advisory Agency in Parentheses)	Form of Compliance	Guidance for Compliance	Area Application
539		EIR 589	SC 4.5-9	Prior to the issuance of a Certificate of Use and Occupancy	Compliance with the WQMP:		Compliance with the WQMP:	Prior to the issuance of a certificate of use and occupancy, the applicant shall demonstrate compliance with the WQMP in a manner meeting the satisfaction of the Manager, Inspection Services Division, including: <ul style="list-style-type: none"> • Demonstrate that all structural Best Management Practices (BMPs) described in the project's WQMP have been implemented, constructed and installed in conformance with approved plans and specifications; • Demonstrate that the applicant has complied with all non-structural BMPs described in the project's WQMP; • Submit for review and approval an Operations and Maintenance (O&M) Plan for all structural BMPs for attachment to the WQMP; 	County of Orange Manager of Building Inspection, Manager, OC Inspection Division	Verification of compliance with Water Quality Management Plan		Each PA
539.1		EIR 589	SC 4.5-9 (cont.)	See above	Water Quality Management Plan (cont.):		Water Quality Management Plan (cont.):	<ul style="list-style-type: none"> • Demonstrate that copies of the project's approved WQMP (with attached O&M Plan) are available for each of the incoming occupants; • Agree to pay for a Special Investigation from the County of Orange for a date (12) twelve months after the issuance of a Certificate of Use and Occupancy for the project to verify compliance with the approved WQMP and O&M Plan; and (County Standard Condition WQ03) 	See above	See above		Each PA
539.2		EIR 589	SC 4.5-9 (cont.)	See above	Water Quality Management Plan (cont.):		Water Quality Management Plan (cont.):	<ul style="list-style-type: none"> • Demonstrate that the applicant has agreed to and recorded one of the following: 1) the CC&R's (that must include the approved WQMP and O&M Plan) for the project Home Owner's Association; 2) a water quality implementation agreement that has the approved WQMP and O&M Plan attached; or 3) the final approved Water Quality Management Plan (WQMP) and Operations and Maintenance (O&M) Plan. (County Standard Condition WQ03) 	See above	See above		Each PA

Item No.	Cross Reference Column	Source	Condition, Mitigation, Public Benefit or Entitlement Provision	Timing	Subject	Keywords	Title	Requirements or Entitlement Provisions	Reviewing / Approving Authority (Advisory Agency in Parentheses)	Form of Compliance	Guidance for Compliance	Area Application
560		EIR 589	SC 4.8-4	Prior to the issuance of certificates of use and occupancy	Multi-Family Residential Development:		Multi-Family Residential Development:	Prior to the issuance of any certificates of use and occupancy, the applicant shall perform field testing in accordance with Title 24 Regulations to verify compliance with FSTC and FIIC standards if determined necessary by the Manager, Building Inspection Services. In the event such a test was previously performed, the applicant shall provide satisfactory evidence and a copy of the report to the Manager, Building Inspection Services, as a supplement to the previously required acoustical analysis report. (County Standard Condition N09)	County of Orange Manager of Building Inspection Services, Manager, OC Inspection Division	Verification of field testing in accordance with Title 24 Regulations to verify compliance with FSTC and FIIC standards or a copy of a previous test		Each PA
563		EIR 589	SC 4.8-7	Prior to the issuance of certificates of use and occupancy	Transportation Corridor Notification:		Transportation Corridor Notification:	Prior to the issuance of certificates of use and occupancy, the developer shall produce evidence to the Manager, Building Inspection Services, that the Department of Real Estate has been notified that the project area is adjacent to a regional transportation corridor. The corridor is expected to be a high capacity, high-speed, limited-access facility for motor vehicles, and will have provisions for bus lanes and other mass transit type facilities. (County Standard Condition N12)	County of Orange Manager of Building Inspection Services, Manager, OC Inspection Division	Submission of evidence that County of Orange Dept. of Real Estate has been notified the project area is adjacent to a regional transportation corridor		Each PA
565		EIR 589	SC 4.10-1 (cont.)	Prior to the issuance of final certificates of use and occupancy and the release of financial security	Public Area Landscaping (cont.):		Public Area Landscaping (cont.):	b. Installation Certification: Prior to the issuance of final certificates of use and occupancy and the release of financial security, if any, guaranteeing the landscape improvements, said improvements shall be installed and shall be certified by a licensed landscape architect or licensed landscape contractor, as having been installed in accordance with the approved detailed plans. (County Standard Condition LA01b)	County of Orange Director of Planning & Development Services & Manager-HBR, Director, OC Planning	Landscaping and irrigation plan certification from landscape architect		Each PA
566		EIR 589	SC 4.10-1 (cont.)	Prior to the issuance of final certificates of use and occupancy and the release of financial security	Public Area Landscaping (cont.):		Public Area Landscaping (cont.):	b. Installation Certification (cont): The applicant shall furnish said certification, including an irrigation management report for each landscape irrigation system, and any other required implementation report determined applicable, to the Manager, Construction, and the Manager, Building Inspection Services, prior to the issuance of any certificates of use and occupancy. (County Standard Condition LA01b)	County of Orange Manager, Construction and Manager, Building Inspection Services, Manager, OC Inspection Division	Approved irrigation management report		Each PA

Item No.	Cross Reference Column	Source	Condition, Mitigation, Public Benefit or Entitlement Provision	Timing	Subject	Keywords	Title	Requirements or Entitlement Provisions	Reviewing / Approving Authority (Advisory Agency in Parentheses)	Form of Compliance	Guidance for Compliance	Area Application
568		EIR 589	SC 4.10-2 (cont.)	Prior to the issuance of certificates of use and occupancy	Private Area Landscaping (cont.):		Private Area Landscaping (cont.):	b. Prior to the issuance of certificates of use and occupancy, applicant shall install said landscaping and irrigation system and shall have a licensed landscape architect or licensed landscape contractor, certify that it was installed in accordance with the approved plan. (County Standard Condition LA02b)	County of Orange Director of Planning & Development Services, Director, OC Planning	Certification from landscape architect that landscaping and irrigation system in accordance with the approved plan		Each PA
569		EIR 589	SC 4.10-2 (cont.)	Prior to the issuance of certificates of use and occupancy	Private Area Landscaping (cont.):		Private Area Landscaping (cont.):	c. Prior to the issuance of any certificates of use and occupancy, the applicant shall furnish said installation certification, including an irrigation management report for each landscape irrigation system, and any other implementation report determined applicable, to the Manager, Building Inspection Services. (County Standard Condition LA02b)	County of Orange Manager, Building Inspection Services, Manager, OC Inspection Division	Approved irrigation management report for each landscape irrigation system		Each PA
618		Fire Prot. Prog.	Cond. 3.f.	Prior to the issuance of any certificate of use and occupancy adjoining fuel modification areas	Occupancy Requirements:		Occupancy Requirements:	f) Prior to the issuance of any certificate of use and occupancy, the applicant shall provide the Manager, Building & Safety, with a clearance from OCFA indicating that: 1. Approved "A" Zone planting has been installed and approved irrigation has been activated. 2. Approved fuel modification zone markers have been installed. 3. Accessways every 500 feet (or as approved) have been installed. 4. Approved thinning of the "B" and "C" Zones and removal of plants from the OCFA Undesirable Plant List have been completed. 5. CC&Rs or other approved documents contain provisions for maintaining the fuel modification zones.	Director, PDS, Director, OC Planning	Provide the Manager, Building & Safety, with a clearance from OCFA indicating installation and thinning		

Item No.	Cross Reference Column	Source	Condition, Mitigation, Public Benefit or Entitlement Provision	Timing	Subject	Keywords	Title	Requirements or Entitlement Provisions	Reviewing / Approving Authority (Advisory Agency in Parentheses)	Form of Compliance	Guidance for Compliance	Area Application
i. Prior to Release of Grading Bond												
572		EIR 589	SC 4.11-1 (cont.)	Prior to the release of the grading bond	Archaeology Grading Observation and Salvage (cont.):		Archaeology Grading Observation and Salvage (cont.):	Prior to the release of the grading bond, the applicant shall obtain approval of the archaeologist's follow-up report from the Manager, Harbors, Beaches & Parks HBP/Coastal and Historical Facilities. The report shall include the period of inspection, an analysis of any artifacts found and the present repository of the artifacts. Applicant shall prepare excavated material to the point of identification. Applicant shall offer excavated finds for curatorial purposes to the County of Orange, or its designee, on a first refusal basis. (County Standard Condition A04)	County of Orange Manager, Harbors, Beaches & Parks HBP/Coastal and Historical Facilities OC Public Works/OC Planning*	Approval of the archaeologist's follow-up report		Each PA
573		EIR 589	SC 4.11-1 (cont.)	Prior to the release of the grading bond	Archaeology Grading Observation and Salvage (cont.):		Archaeology Grading Observation and Salvage (cont.):	These actions, as well as final mitigation and disposition of the resources shall be subject to the approval of the Manager, HBP/Coastal and Historical Facilities. Applicant shall pay curatorial fees if an applicable fee program has been adopted by the Board of Supervisor, and such fee program is in effect at the time of presentation of the materials to the County of Orange or its designee, all in a manner meeting the approval of the Manager, HBP/Coastal and Historical Facilities. (County Standard Condition A04)	County of Orange Manager, Harbors, Beaches & Parks HBP/Coastal and Historical Facilities OC Public Works/OC Planning*	Verification of payment of curatorial fee if an applicable fee program has been adopted by the Board of Supervisor at the time of presentation		Each PA
575		EIR 589	SC 4.11-2 (cont.)	Prior to the release of the grading bond	Paleontology Resource Surveillance (cont.):		Paleontology Resource Surveillance (cont.):	Prior to the release of any grading bond, the contractor shall submit the paleontologist's follow up report for approval by the County Manager, HBP/Coastal and Historical Facilities. The report shall include the period of inspection, a catalogue and analysis of the fossils found, and the present repository of the fossils. The contractor shall prepare excavated material to the point of identification. The contractor shall offer excavated finds for curatorial purposes to the County of Orange, or its designee, on a first-refusal basis. (County Standard Condition A07)	County of Orange Manager, Harbors, Beaches & Parks HBP/Coastal and Historical Facilities OC Public Works/OC Planning*	Approval of the paleontologist's follow-up report		Each PA

Item No.	Cross Reference Column	Source	Condition, Mitigation, Public Benefit or Entitlement Provision	Timing	Subject	Keywords	Title	Requirements or Entitlement Provisions	Reviewing / Approving Authority (Advisory Agency in Parentheses)	Form of Compliance	Guidance for Compliance	Area Application
576		EIR 589	SC 4.11-2 (cont.)	Prior to the release of the grading bond	Paleontology Resource Surveillance (cont.):		Paleontology Resource Surveillance (cont.):	These actions, as well as final mitigation and disposition of the resources, shall be subject to approval by the HBP/Coastal and Historical Facilities. The contractor shall pay curatorial fees if an applicable fee program has been adopted by the Board of Supervisors, and such fee program is in effect at the time of presentation of the materials to the County of Orange or its designee, all in a manner meeting the approval of the County Manager, HBP/Coastal and Historical Facilities. (County Standard Condition A07)	County of Orange Manager, Harbors, Beaches & Parks, HBP/Coastal and Historical Facilities OC Public Works/OC Planning*	Verification of payment of curatorial fee if an applicable fee program has been adopted by the Board of Supervisor at the time of presentation		Each PA

ATTACHMENT 1



RANCHO MISSION VIEJO

February 15, 2024, updated March 20, 2024

Bea Bea Jiménez
Division Manager
Land Development
OC Public Works
601 North Ross Street
Santa Ana, CA 92701

SUBJECT:

Application for “B” Vesting Tentative Tract Map 19306 within Rancho Mission Viejo (Ranch Plan) Planning Area 3, Subarea 3.4 for the AQ22 Lennar project

Dear Ms. Jiménez,

PROPOSAL:

Rancho Mission Viejo requests Subdivision Committee approval of Vesting Tentative Tract Map 19306 within Rancho Mission Viejo (Ranch Plan) Planning Area 3, Subarea 3.4 for the AQ22 project to allow 72 Planned Concept Detached Dwellings on 72 numbered residential lots and 15 lettered lots for usable open space, slopes/landscape, and private motor court purposes.

ZONING:

Ranch Plan Planned Community (PC) – Subarea Plan 3.4 **Planned Concept**

LOCATION:

The AQ12 project site is located within the Ranch Plan Planned Community - Planning Area 3 (PA3), Subarea 3.3 and Vesting Tentative Tract Map 17934, Lots 8-19 in unincorporated Orange County, California.

LANDOWNER/SUBDIVIDER:

The specific land ownership entity for the proposed project site is RMV PA3 Development LLC (referred to as Rancho Mission Viejo, or “RMV”). The site will eventually be owned by, and homes built by **Lennar**.

BACKGROUND AND EXISTING CONDITIONS:

In November 2004, the County of Orange approved the Ranch Plan Planned Community, which encompasses approximately 22,815 acres located east of I-5, north and south of Ortega Highway, within the Fifth Supervisorial District. As approved, the Ranch Plan Planned Community encompasses 75 percent permanent open space, with development of 14,000 dwelling units and 5,200,000 square feet (SF) of non-residential uses allowed within the remaining 25 percent. It is regulated by the Ranch Plan PC Program Text which addresses the unique characteristics of the property and a development plan for the transition to suburban/urban uses occurring over a 25- to 30-year period.

The Master Area Plan and Subarea Plans for Planning Area 3 were approved on October 27, 2022 including Subarea Plan 3.3 (PA22-0067). VTTM 17933 for Subarea Plan 3.3 and VTTM 17934 for Subarea Plan 3.4 were approved by the OC Subdivision Committee on December 6, 2023. Grading for Subareas 3.3 and 3.4 are currently in progress under GRD22-0136 and GRD23-0059.

PROPOSED PROJECT:

The applicant (RMV) requests approval of Vesting Tentative Tract Map 19306 to allow 72 Planned Concept **units** on 72 numbered residential lots and 15 lettered lots for landscaped open space and private motor court purposes, all within the proposed 9.78-acre project site. Subsequent SDP will be submitted by RMV and construction level building applications to be submitted by Lennar. The project will also include street and infrastructure improvements, landscaping, and minor precise grading.

The 72 numbered lots range in size from 3,477 square feet up to 8,062 square feet. The site has a net residential acreage of 8.01 acres (excluding streets, motorcourts, alleys and HOA slopes) for a net residential density of 8.99 dwelling units per acre.

SURROUNDING LAND USE:

Land uses immediately surrounding the project site include the following:

- Westerly: Subarea 3.4 – future residential
- Southerly: Subarea 3.4 – future residential
- Easterly: Subarea 3.4 - future residential
- Northerly: Subarea 3.11 – future **open space / slope area**

REFERRAL FOR COMMENT AND PUBLIC NOTICE:

The applicant understands that the tentative map application submittal will be distributed for review and comment to County staff and consultants, including Land Development, OC Infrastructure Programs, Inspection Services, Building & Safety, OC Survey, and Orange County Fire Authority. We also understand that the VTTM must be approved by the OC Subdivision Committee at a Public Meeting with a public notice mailed to all property owners of record within 300 feet of the subject, and posted at the site, at the Orange County Hall of Administration, and at 601 N. Ross Street, as required by established public meeting posting procedures.

CONSISTENCY ANALYSIS:

The proposed SDP and VTTM are consistent with the Ranch Plan PC Program Text Use Regulations & Development Standards (PC Program Text, Section III), as described below:

- a. General Plan – The OC General Plan Land Use Element designates Subarea 3.4 of Ranch Plan as “1B, Suburban Residential (0.5 to 18 du/ac)”, per GPA 01-01. The proposed SDP and VTTM are consistent with the 1B “Suburban Residential designation.
- b. Zoning – The proposed SDP and VTTM are consistent with the Ranch Plan Planned Community zoning, including all applicable requirements of the PC Program Text Use Regulations & Development Standards (PC Section III).
- c. State Subdivision Map Act and County of Orange Subdivision Code and Manual – In Compliance.
- d. Area Plans – The proposed SDP and VTTM are consistent with land uses and other details of PA3&4 Master Area Plan and Subarea Plan 3.4 (PA22-0067)

- e. CEQA – The proposed SDP and VTTM are consistent with Final EIR 589, previously certified on November 8, 2004; Addendum 1.0 (PA060023) approved July 26, 2006; Addendum 1.1 (PA110003-06) approved February 24, 2011; the Planning Area 2 Addendum (PA130001-06) approved March 27, 2013; and Addendum 3.1 (PA140072-81) approved February 25, 2015.
- f. Alternative Development Standards – All Alternative Development Standards incorporated into this project have been previously approved by the appropriate decision maker per the Ranch Plan Planned Community Program Text, General Regulation 25.
- g. Regulation Compliance Matrix – Clearance of all applicable conditions of approval have been confirmed per the Ranch Plan Regulation Compliance Matrix.

Estimated Earthwork

The proposed estimated grading quantities for this map are substantially consistent with or less than the earthwork quantities described under previous approvals (i.e. Master Area Plan (PA3&4), Subarea Plan 3.3, VTTM 17933, VTTM 17934, and Subarea 3.4 Rough Grading Permit GRD23-0059 currently in process. The proposed grading on this map has been addressed per CEQA document FEIR 589, together with Addendum 3.1 (PA140072-81) approved February 25, 2015.

Drainage:

The subject property is in the Ranch Plan Planned Community Runoff Management Plan Area. No Master Plan of Drainage (MPD) facilities have been identified or approved within the site and no MPD fees are required.

Recreation and Open Space:

The proposed map is not required to provide any improvements or dedications associated with the County Master Plan of Regional Recreation Facilities; Master Plan of Regional Riding and Hiking Trails; Resources Element (Open Space Component); or OCTA Strategic Plan for Bikeways.

- Master Plan of Regional Recreation Facilities - There are no regional park dedication requirements of the subject map.
- Master Plan of Regional Riding and Hiking Trails - There are no riding and hiking trail requirements of the subject map.
- Master Plan of Local Parks (Local Park Code) - The proposed map is required to provide park land in accordance with the Master Plan of Local Parks (Local Park Code). The Local Park Code requirement for the subject map VTTM 19306 is 0.432 net usable acres of park land based upon a proposal to build 72 dwelling units at a gross residential density of 7.36du/ac (72 du x .006 ac/du). Said requirement can be satisfied by an allocation of parkland credit from Park Modification PM07-01, the Local Park Implementation Plan (LPIP) for the Ranch Plan P.C. originally approved March 14, 2007, 1st Amendment approved in June 2012, 2nd Amendment approved on July 16, 2014, 3rd Amendment approved November 7, 2019, and 4th Amendment approved December 6, 2023. Per the Ranch Plan LPIP, the total parkland acreage requirement for the entire Ranch Plan Planned Community is 94.0 acres, based on 14,000 approved dwelling units and the anticipated proportion of single-family and multi-family units. The Ranch Plan LPIP (PM07-01) indicates that far more acres of total community-wide parkland will be implemented in Planning Area 3&4 than would be required per County standards, based on the 7,500 dwelling units entitled by the PA3&4 Master Area Plan PA180030, per the parkland generation factor for each unit (greater than 6.5 du/ac requires 0.006 acres and less than 6.5 du/ac requires 0.008 acres).

- Resources Element - Open Space Component - There are no open space dedication requirements of the subject map.
- OCTA Strategic Plan for Bikeways - There are no County-wide bikeways identified within the area of this map.

Public Services & Utilities

- Schools - This property is within the boundaries of the Capistrano Unified School District. The developer is subject to the provisions of Assembly Bill AB 2926, or other mitigating measures designed to provide for school facilities and/or funding, such as community facilities districts. No school site is proposed for Subarea 3.4.
- Facilities Fees Programs - This project area is included within the Ranch Plan Planned Community Development Facility Agreement area which phases development commensurate with public services and facilities.
- Water/Sewer - This project is within the boundaries of the Santa Margarita Water District. The District stated in their "will-serve" letter dated ###/##/2024, that the District will be capable of providing water and sewage disposal service to this development.
- Water Quality Control - This project will be required to operate in accordance with requirements prescribed by the California Regional Water Quality Control Board, San Diego Region.
- Fire Protection and Safety - Existing and proposed fire protection services will be providing an adequate level of fire protection services to this development, per the TT19305 Fire Master Plan approved by OCFA ###/##/2024. Additionally, this property is within the area covered by the approved Ranch Plan Fire Protection Program, which includes all applicable conditions of approval and regulations.
- County Service Area (CSA) - This property is within the boundaries of County Service Area No. 26.

Traffic/Circulation

- Scenic Highway Corridors - There are no Scenic Highways applicable to this map
- Access/Highways/Streets/Roads - Access to the site is Lamkin Lane. Internal tract access will be provided by internal private alleys and motor courts.
- Major Thoroughfare and Bridge Fee Program - This project lies within the area of benefit of the Foothill/Eastern Transportation Corridor. The developer is required to pay Foothill/Eastern Major Thoroughfare and Bridge fees in accordance with the adopted program.
- Off-Site Fee Program – The project lies within the area of benefit of the South County Roadway Improvement Road Fee Program (SCRIP). The developer is required to pay SCRIP fees in accordance with the adopted program.

Multiple Final Map Phasing

As indicated by Note 19 on this TT19306, the option of multiple final maps phasing has been requested as part of the approval of this Vesting Tentative Tract Map.

DEVIATIONS FROM STANDARDS OF DESIGN:

The developer may request deviations from County standard design criteria in accordance with Subdivision Code section 7-9-291. In the absence of any specifically approved deviation request, the County-approved standard design criteria will prevail. No deviations are requested with this map.

ALTERNATIVE DEVELOPMENT STANDARDS:

As indicated by Note 30 on this TT19306, as allowed by General Regulation #25 of the Ranch Plan Planned Community Program Text, proposed Alternative Development Standards are intended to be incorporated into the development.

Upon review of this application our hope is that staff supports OC Subdivision Committee approval of the "B" tentative tract map. Please contact me with any questions, or if you or your staff need any further information.

Sincerely,

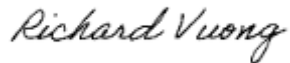
A handwritten signature in cursive script that reads "Richard Vuong".

Richard Vuong
Project Director, Planning and Entitlement
Rancho Mission Viejo

ATTACHMENT 2

BOARD OF DIRECTORS

LAURA FREESE
CHARLES T. GIBSON
SAUNDRA F. JACOBS
BETTY H. OLSON, PH.D
FRANK URY

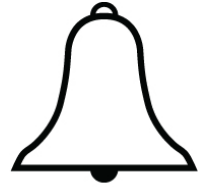

DON BUNTS
INTERIM GENERAL MANAGER

Santa Margarita Water District

June 7, 2024

County of Orange
OC Public Works
OC Development Services
601 N. Ross Street
Santa Ana, California 92703

Subject: Preliminary Water and Sewer Letter for RMV Community Development, LLC, VTTM 19306, Rancho Mission Viejo, in Improvement District No. 5

Greetings:

This letter is in response to a request by Lennar Homes (Developer) for a preliminary water and sewer letter for the subject tract.

The Santa Margarita Water District (District) supplies all of its current customers with domestic water purchased from the Metropolitan Water District of Southern California (Metropolitan) through the Municipal Water District of Orange County (MWDOC), which acts as a wholesaler to its member agencies. It is anticipated the subject tract would also be supplied with available domestic water purchased from Metropolitan through MWDOC. Supplemental water for this development, if required, will be provided per the approved The Ranch Plan Planning Area 3 and 4 Water Supply Verification, dated October 2017. Subject to the Developer’s successful completion of the in-tract water and recycled water and the District’s construction of the off-site water and recycled water facilities, the District can and will provide domestic and recycled water service to each and every building parcel in the subject tract without exception.

Furthermore, and subject to the Developer’s successful completion of the in-tract sewer facilities and the District’s construction of off-site sewer facilities, the District can and will provide sewer service to each and every building lot within the subject tract without exception.

At this time, the Developer has not provided surety to guarantee the construction of the in-tract water, recycled water and sewer facilities. A final will-serve will be issued upon your request when (1) the Developer has guaranteed the construction of the in-tract facilities and (2) construction of the District’s water and sewer facilities is assured.

Should you have any questions or desire additional information, please call Karla Houlihan at (949) 459-6581.

Sincerely,
SANTA MARGARITA WATER DISTRICT

Patricia A Butler
Chief Engineer

S:\ENGINEERING\PRELIMINARY WILL SERVE\2024\Will Serve VTTM 19306.doc

ATTACHMENT 3

VICINITY MAP

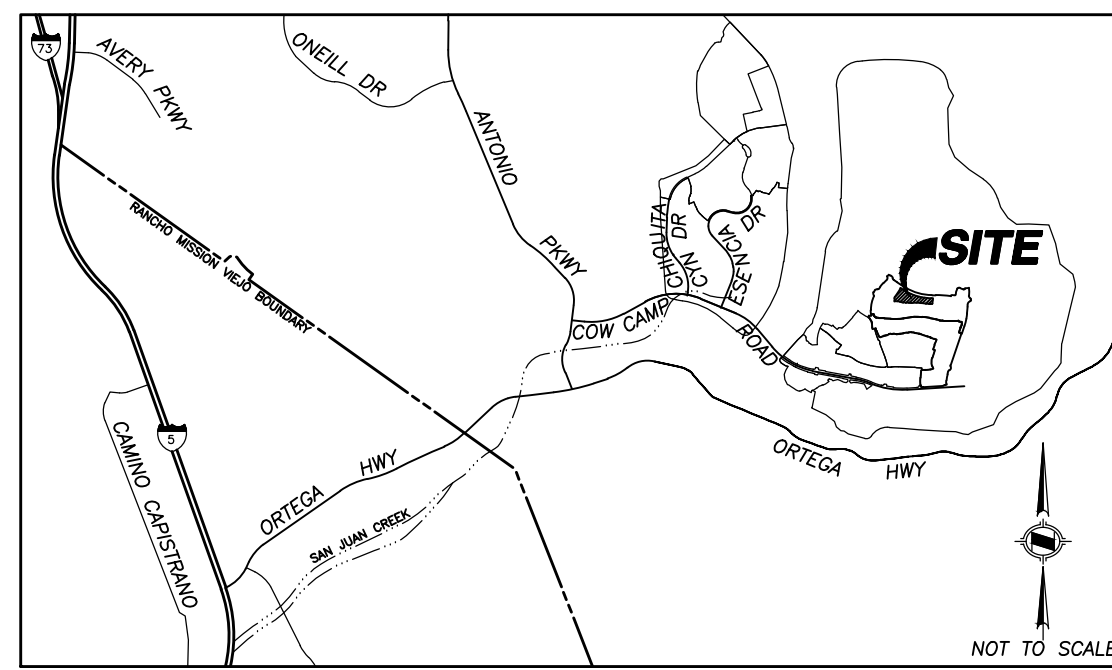

VESTING TENTATIVE TRACT MAP 19306 GAVILAN RIDGE AQ22

LEGAL DESCRIPTION

LOTS 8 THROUGH 19, IN THE UNINCORPORATED TERRITORY OF THE COUNTY OF ORANGE, STATE OF CALIFORNIA, AS SHOWN ON "A" TRACT 17934.

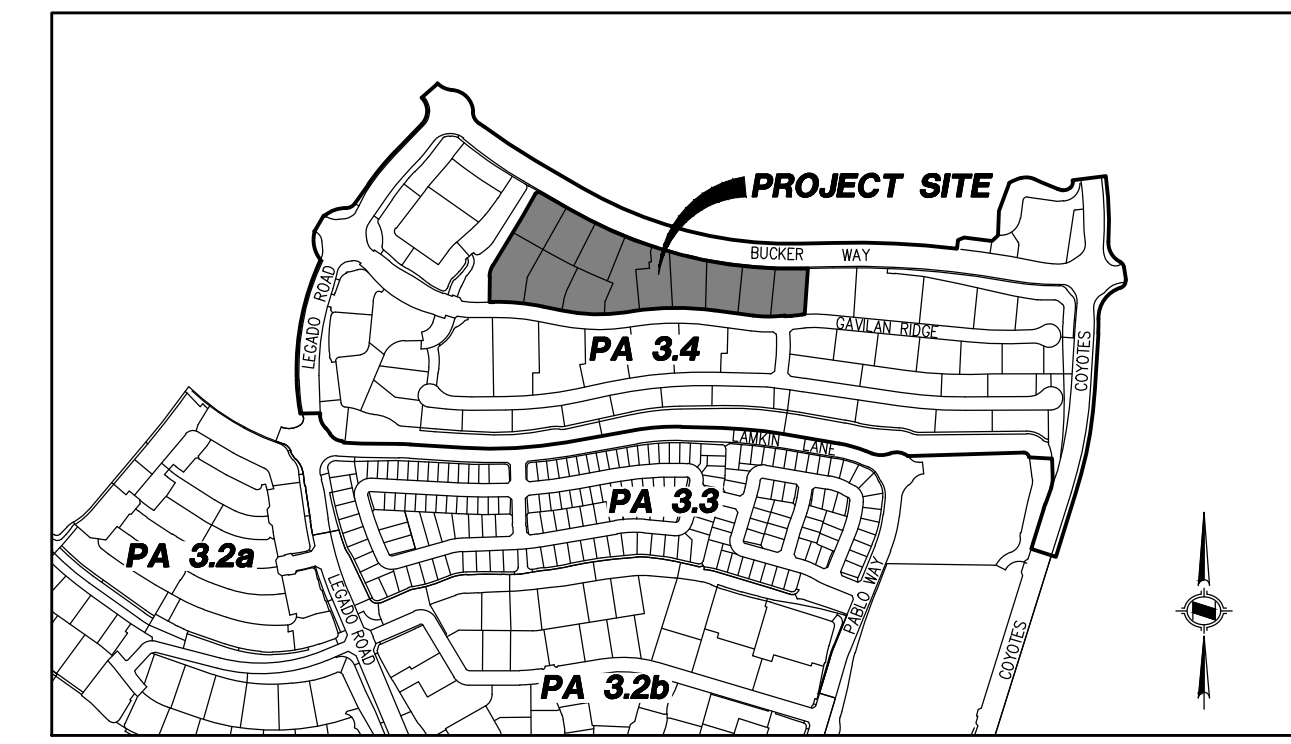

LOCATION MAP

LEGEND

- Legend items: PROJECT BOUNDARY, PROPOSED LOT LINE, PROPOSED CONTOUR LINE, RIGHT OF WAY, TOP OF SLOPE, TOE OF SLOPE, DAYLIGHT LINE, PROPOSED EASEMENT, PROPOSED RETAINING WALL, MASS GRADED CONTOUR, PAD ELEVATION, SUB AREA PLAN BOUNDARY, STORM DRAIN, WATER, SEWER, PROPOSED FIRE HYDRANT, LOT NUMBER, PAD ELEVATION, FIRE HAMMERHEAD TURNAROUND, LINE OF SIGHT TRIANGLE.

EASEMENT NOTES

- Easement notes: 1. INDICATES AN EASEMENT FOR SEWER, WATER AND ACCESS PURPOSES DEDICATED PER FINAL MAP 19306 TO THE SANTA MARGARITA WATER DISTRICT. 2. INDICATES A RECIPROCAL INGRESS/EGRESS EASEMENT, MINIMUM 30 FOOT WIDE FOR THE BENEFIT OF ALL LOTS IN TRACT NO. 19306. 3. INDICATES AN EASEMENT FOR WATER AND ACCESS PURPOSES DEDICATED PER FINAL MAP 17934 TO THE SANTA MARGARITA WATER DISTRICT.

SLOPE DESIGNATIONS:

- Slope designations: ALL MANUFACTURED SLOPES TO HAVE TERRACE AND DOWN DRAINS AS REQUIRED BY THE COUNTY OF ORANGE GRADING CODE REQUIREMENTS, BUT ARE NOT SHOWN HEREON FOR CLARITY. (A) MAINTAINED BY THE HOA (B) MAINTAINED BY INDIVIDUAL LOT OWNER

BENCHMARK

OCS BM "AP-02-00" (NAVD88) ELEVATION: 238.11' FOUND 1-3/4" OCS ALUMINUM BENCHMARK DISK STAMPED "AP-02-99", SET IN THE NORTHEASTERLY CORNER OF A CONCRETE BRIDGE DECK, MONUMENT IS LOCATED IN THE NORTHEASTERLY CORNER OF ANTONIO PARKWAY AND ITS OVERCROSSING OF SAN JUAN CREEK.

STATEMENT OF OWNERSHIP

RMV PA3 DEVELOPMENT, LLC, IS THE OWNER OF THAT PORTION OF PA3 COVERED BY TRACT NO. 19306 AND AUTHORIZED TO EXECUTE AND DELIVER ALL DOCUMENTS THAT ARE NECESSARY AND APPROPRIATE FOR PROCESSING AND IMPLEMENTING THE PA3 DEVELOPMENT PROGRAM. SAID AUTHORIZATION INCLUDES, BUT IS NOT LIMITED TO THE EXECUTION AND DELIVERY OF SUCH APPLICATIONS, AGREEMENTS AND OTHER DOCUMENTS AS ARE REQUIRED BY THE COUNTY OF ORANGE IN CONNECTION WITH THE PROCESSING AND DEVELOPMENT OF PA3.

DATED THIS May 3, 2024 BY: [Signature] PRINTED NAME: Kris Maher TITLE: Sr. V.P. Community Development

NOTES

- Notes 1-37: 1. EXISTING LAND USE: VACANT LAND, PREVIOUSLY MASS GRADED PER GRD22-0016 & ROUGH GRADED PER GRD23-0059 TO ALLOW FOR FUTURE DEVELOPMENT. 2. PROPOSED LAND USE: RESIDENTIAL - 72 DWELLING UNITS. THIS SITE DEVELOPMENT PERMIT MORE SPECIFICALLY IDENTIFIES THIS SITE AS PLANNED CONCEPT DETACHED DWELLINGS - PER PC TEXT SECTION III.A.2.A.3. 3. EXISTING ZONING: VTM 19306 IS LOCATED WITHIN RANCH PLAN PLANNED COMMUNITY PLANNING AREA 3, IS ZONED AS A DEVELOPMENT AREA BY THE RANCH PLAN PC TEXT, AND SHALL BE PROCESSED PER THE IMPLEMENTATION PROCEDURES DETAILED IN SECTION I.C OF THE PC TEXT. 4. THE PLANNING AREA 3 MASTER AREA PLAN AND SUBAREA PLAN 3.4 (PA22-0067) DESIGNATE THE PROJECT SITE AS RESIDENTIAL. 5. GRADING PLANS MAY BE PROCESSED CONCURRENTLY WITH A TENTATIVE TRACT MAP, PER A CONCURRENT PROCESSING REQUEST LETTER. PLAN CHECKING OF ROUGH GRADE PLANS OR PRECISE GRADE PLANS MAY PROCEED, BUT APPROVAL OF THE GRADING PLAN MUST FOLLOW VTM APPROVAL. 6. CALIFORNIA ENVIRONMENTAL QUALITY ACT (CEQA) IMPACTS HAVE BEEN ADDRESSED BY THE RANCH PLAN FINAL PROGRAM EIR 589 AND ADDENDUM 3.1. 7. NORTH FUTURE OPEN SPACE/SLOPE AREA AND FUTURE RESIDENTIAL RANCH PLAN PLANNED COMMUNITY SOUTH PUBLIC STREET/FUTURE RESIDENTIAL RANCH PLAN PLANNED COMMUNITY EAST PUBLIC STREET/FUTURE RESIDENTIAL RANCH PLAN PLANNED COMMUNITY WEST FUTURE RESIDENTIAL RANCH PLAN PLANNED COMMUNITY 8. SANITARY SEWER SERVICES PROVIDED BY: SANTA MARGARITA WATER DISTRICT. 9. DOMESTIC WATER SERVICE PROVIDED BY: SANTA MARGARITA WATER DISTRICT. 10. NON-DOMESTIC RECYCLED WATER SERVICE PROVIDED BY: SANTA MARGARITA WATER DISTRICT. 11. ALL PROPOSED UTILITIES ARE TO BE UNDERGROUND WITH THE EXCEPTION OF ELECTRICAL TRANSMISSION LINES GREATER THAN 68KV. PROPOSED UTILITY LOCATIONS SHOWN ON THE MAP ARE APPROXIMATE. ACTUAL LOCATIONS AND EASEMENT WIDTHS WILL BE REFLECTED ON FINAL TRACT MAP(S). GAS: SOUTHERN CALIFORNIA GAS COMPANY ELECTRIC: SAN DIEGO GAS AND ELECTRIC TELEPHONE: AT&T AND COX COMMUNICATIONS CABLE TELEVISION: COX COMMUNICATIONS 12. PROJECT SITE IS WITHIN THE CAPISTRANO UNIFIED SCHOOL DISTRICT. 13. DRAINAGE SYSTEM WILL BE DEVELOPED IN ACCORDANCE WITH THE O.C. PUBLIC WORKS AND COUNTY OF ORANGE FLOOD CONTROL DISTRICT STANDARDS IN ACCORDANCE WITH THE APPLICABLE "MASTER PLAN OF DRAINAGE" AND THE RUN OFF MANAGEMENT PLAN (ROMP). PA3 & 4 APPROVED ON 11-15-23. DRAINAGE SYSTEM WILL BE DEVELOPED IN ACCORDANCE WITH THE ORANGE FLOOD CONTROL DISTRICT STANDARDS AND THE "MASTER PLAN OF DRAINAGE" FOR TRACT NO. 17934 PREPARED BY HUNSAKER AND ASSOCIATES. STORM FLOWS TRIBUTARY TO THE SITE SHALL BE INTERCEPTED AND CONVEYED AROUND THE SITE VIA THE STORM DRAIN SYSTEMS SHOWN HEREON. ALL STORM DRAINS SHOWN HEREON ARE PRELIMINARY. STORM DRAIN PLANS WILL BE PREPARED. 14. STREET IMPROVEMENTS SHOWN HEREON SHALL MEET THE REQUIREMENTS OF THE COUNTY OF ORANGE AND THE RANCH PLAN ALTERNATIVE DEVELOPMENT STANDARDS. ALL WORK SHALL BE IN CONFORMANCE WITH THE LATEST EDITIONS OF BOTH THE COUNTY OF ORANGE, O.C. PUBLIC WORKS (OCPW) STANDARD PLANS AND THE STANDARD SPECIFICATIONS FOR PUBLIC WORKS CONSTRUCTION AS PUBLISHED BY BNI BUILDING NEWS (GREENBOOK), EACH OF WHICH SHALL BE KEPT ON THE WORK SITE AT ALL TIMES. DESIGN OF ALL WORK SHALL BE IN CONFORMANCE WITH THE LATEST EDITIONS OF THE ORANGE COUNTY HIGHWAY DESIGN

ENGINEERS STATEMENT

I HEREBY STATE THAT THIS MAP WAS PREPARED UNDER MY SUPERVISION AND THAT THE OWNER OF RECORD HAS KNOWLEDGE OF AND CONSENTS TO THE FILING OF THIS MAP. [Signature] N. Streeter DATE: 9/26/2024

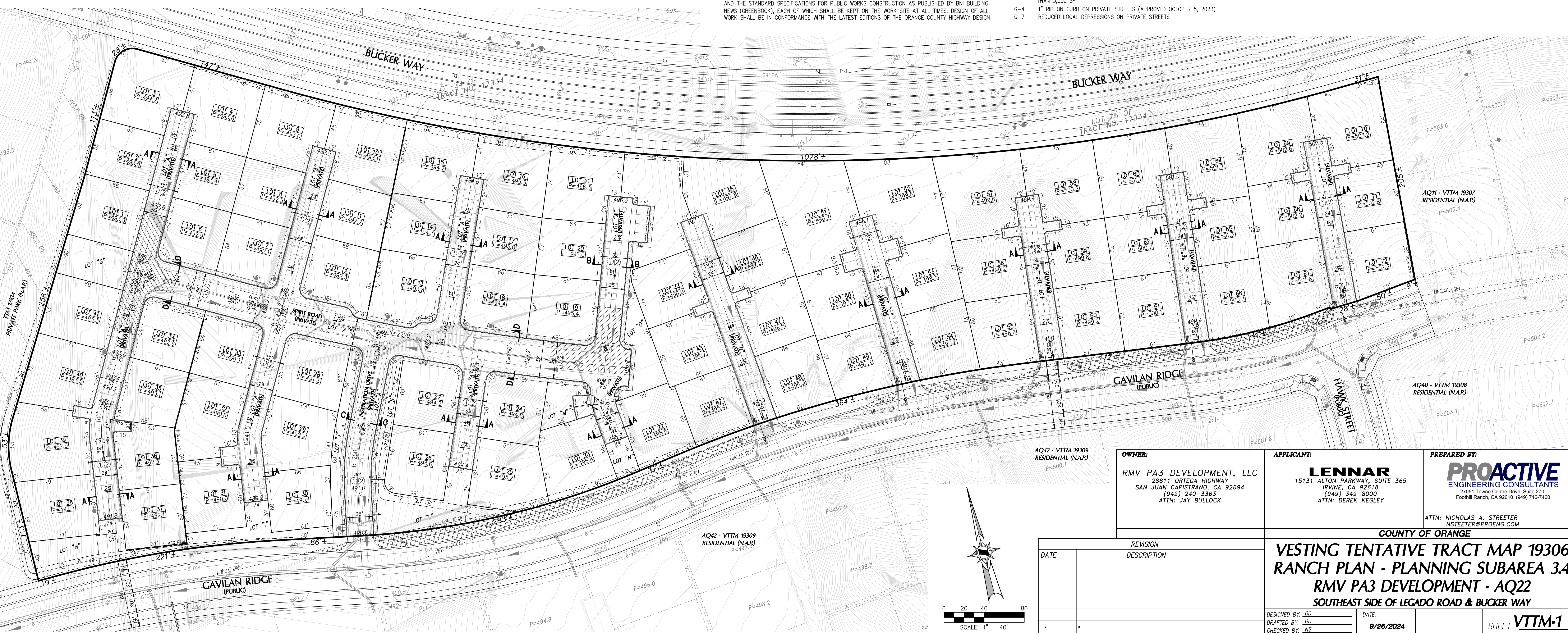
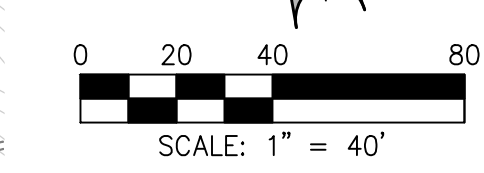
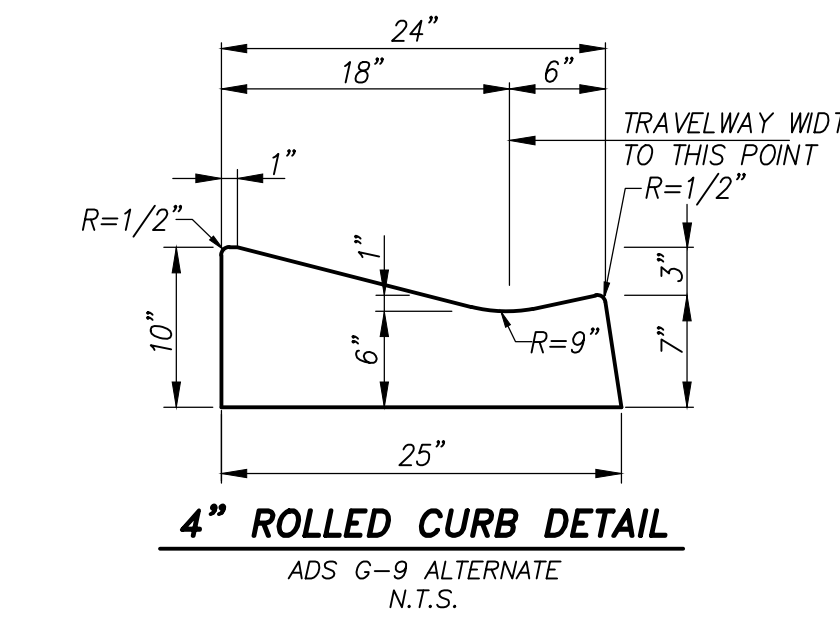
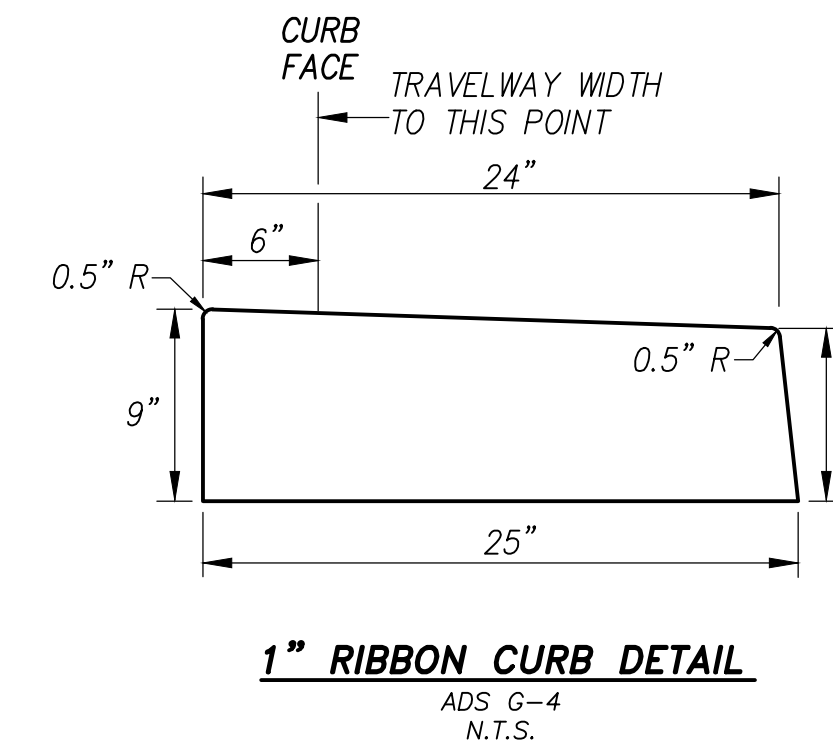
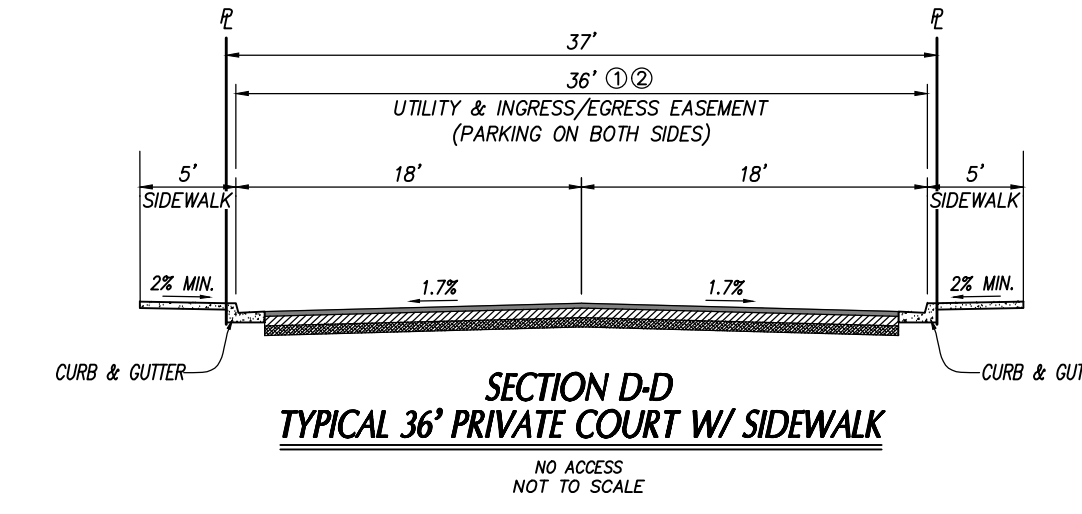
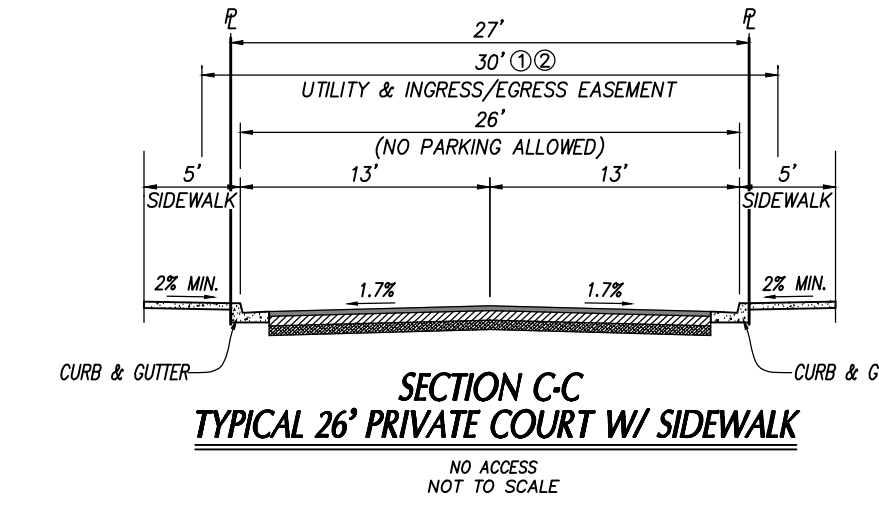
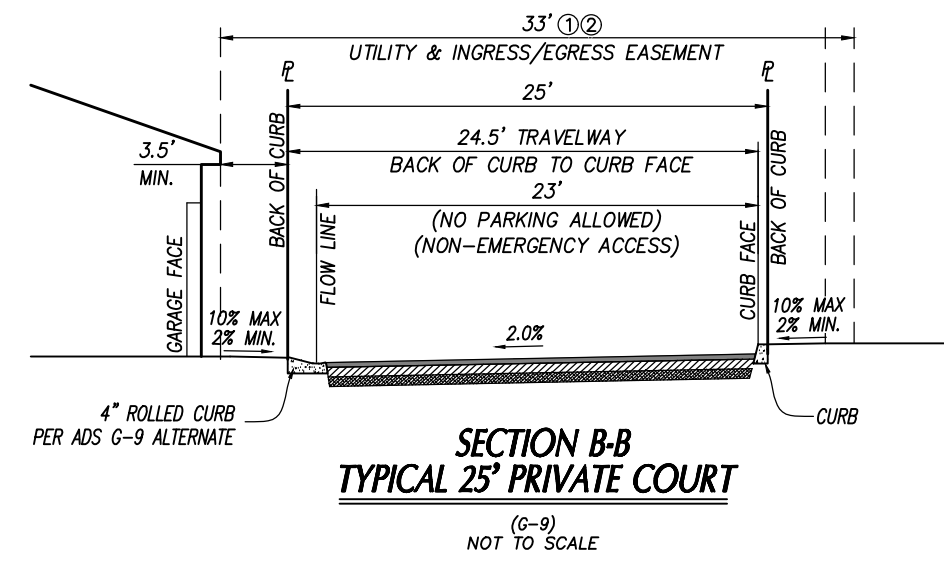
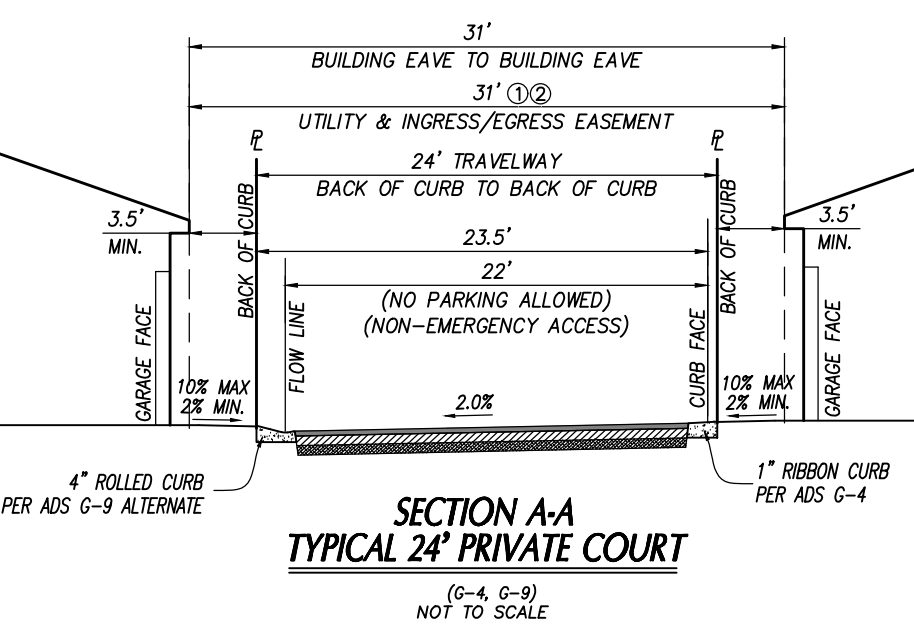

Table with project details: OWNER (RMV PA3 DEVELOPMENT, LLC), APPLICANT (LENNAR), PREPARED BY (PROACTIVE ENGINEERING CONSULTANTS), COUNTY OF ORANGE, VESTING TENTATIVE TRACT MAP 19306 RANCH PLAN - PLANNING SUBAREA 3.4 RMV PA3 DEVELOPMENT - AQ22 SOUTHEAST SIDE OF LEGADO ROAD & BUCKER WAY. Includes revision table and design/drafting info.



TYPICAL STREET SECTIONS & DETAILS



NUMBERED LOT AREA SUMMARY

LOT NUMBER	LOT SIZE S.F.	LOT SIZE ACRES	LOT NUMBER	LOT SIZE S.F.	LOT SIZE ACRES	LOT NUMBER	LOT SIZE S.F.	LOT SIZE ACRES	LOT NUMBER	LOT SIZE S.F.	LOT SIZE ACRES
1	4,187	0.10	19	4,295	0.10	37	3,629	0.08	55	4,270	0.10
2	3,762	0.09	20	3,678	0.08	38	4,544	0.10	56	4,092	0.09
3	5,524	0.13	21	5,110	0.12	39	5,492	0.13	57	6,518	0.15
4	5,147	0.12	22	4,310	0.10	40	4,807	0.11	58	5,294	0.12
5	3,477	0.08	23	4,701	0.11	41	4,375	0.10	59	3,706	0.09
6	3,885	0.09	24	4,121	0.09	42	3,917	0.09	60	4,318	0.10
7	3,883	0.09	25	4,713	0.11	43	4,001	0.09	61	4,437	0.10
8	3,477	0.08	26	4,087	0.09	44	3,884	0.09	62	3,706	0.09
9	5,098	0.12	27	4,121	0.09	45	5,687	0.13	63	5,253	0.12
10	5,306	0.12	28	4,331	0.10	46	3,995	0.09	64	5,409	0.12
11	3,777	0.09	29	4,563	0.10	47	3,951	0.09	65	3,706	0.09
12	4,427	0.10	30	3,795	0.09	48	4,169	0.10	66	4,459	0.10
13	4,727	0.11	31	4,206	0.10	49	3,952	0.09	67	4,928	0.11
14	3,706	0.09	32	4,678	0.11	50	4,115	0.09	68	3,839	0.09
15	5,130	0.12	33	3,886	0.09	51	8,062	0.19	69	5,023	0.12
16	5,089	0.12	34	3,885	0.09	52	6,676	0.15	70	5,405	0.12
17	3,677	0.08	35	3,676	0.08	53	4,273	0.10	71	3,706	0.09
18	4,293	0.10	36	3,674	0.08	54	4,354	0.10	72	3,914	0.09
TOTAL										320,268	7.35

LETTERED LOT AREA SUMMARY

LOT NUMBER	LOT SIZE		USE
	SQ. FT.	ACRES	
A	53595	1.23	PRIVATE COURT
B	5535	0.13	PRIVATE COURT
C	4776	0.11	PRIVATE COURT
D	4392	0.10	PRIVATE COURT
E	4443	0.10	PRIVATE COURT
F	4268	0.10	PRIVATE COURT
G	2740	0.06	USABLE OPEN SPACE
H	3841	0.09	USABLE OPEN SPACE
I	2484	0.06	USABLE OPEN SPACE
J	2554	0.06	SLOPE / LANDSCAPE
K	1835	0.04	SLOPE / LANDSCAPE
L	4565	0.10	USABLE OPEN SPACE
M	1541	0.04	USABLE OPEN SPACE
N	878	0.02	USABLE OPEN SPACE
O	8419	0.19	USABLE OPEN SPACE
105,906		2.43	

PROJECT SUMMARY & USABLE PROJECT OPEN SPACE CALCULATIONS

PROJECT SUMMARY					
LOT NUMBERS	TOTAL LOTS	ACRES	GROSS %	NET %	PROPOSED LAND USE
I-72	72	7.35	75.15%	91.73%	PLANNED CONCEPT DETACHED DWELLINGS
A-F	6	1.77	18.08%	-	PRIVATE COURT
G-I, L-O	7	0.56	5.74%	7.01%	USABLE OPEN SPACE
J-K	2	0.10	1.03%	1.26%	SLOPE/ LANDSCAPE
TOTALS	87	9.78	100.00%	100.00%	
GROSS DEVELOPMENT AREA	9.78	ALL LOTS 1-72, A-O	7.36	DUJAC GROSS DENSITY	
NET DEVELOPMENT AREA	8.01	LESS PRIVATE COURTS	8.98	DUJAC NET DENSITY	
NET RESIDENTIAL AREA	7.89	(GROSS SITE AREA - STREETS, ALLEYS, DRIVEWAYS, HOA SLOPES AND FUEL MOD)			
USABLE PROJECT OPEN SPACE					
REQUIRED USABLE PROJECT OPEN SPACE	5%	NET RESIDENTIAL AREA X 0.05	0.39	ACRES	
PROVIDED USABLE PROJECT OPEN SPACE	5.74%	PROVIDE USABLE OPEN SPACE AREA	0.45	ACRES	

OWNER: RMV PA3 DEVELOPMENT, LLC 28811 ORTEGA HIGHWAY SAN JUAN CAPISTRANO, CA 92694 (949) 240-3363 ATTN: JAY BULLOCK	APPLICANT: LENNAR 15131 ALTON PARKWAY, SUITE 365 IRVINE, CA 92618 (949) 349-8000 ATTN: DEREK KEGLEY	PREPARED BY: PROACTIVE ENGINEERING CONSULTANTS 27051 Towne Centre Drive, Suite 270 Foothill Ranch, CA 92610 (949) 716-7460 ATTN: NICHOLAS A. STREETER NSTEETER@PROENG.COM
---	--	---

REVISION		COUNTY OF ORANGE	
DATE	REVISION	VESTING TENTATIVE TRACT MAP 19306	
	DESCRIPTION	RANCH PLAN - PLANNING SUBAREA 3.4	
		RMV PA3 DEVELOPMENT - AQ22	
		SOUTHEAST SIDE OF LEGADO ROAD & BUCKER WAY	
DESIGNED BY: <u>JD</u>	DATE: <u>9/26/2024</u>	SHEET VTTM-2	
DRAFTED BY: <u>JD</u>			
CHECKED BY: <u>NS</u>			

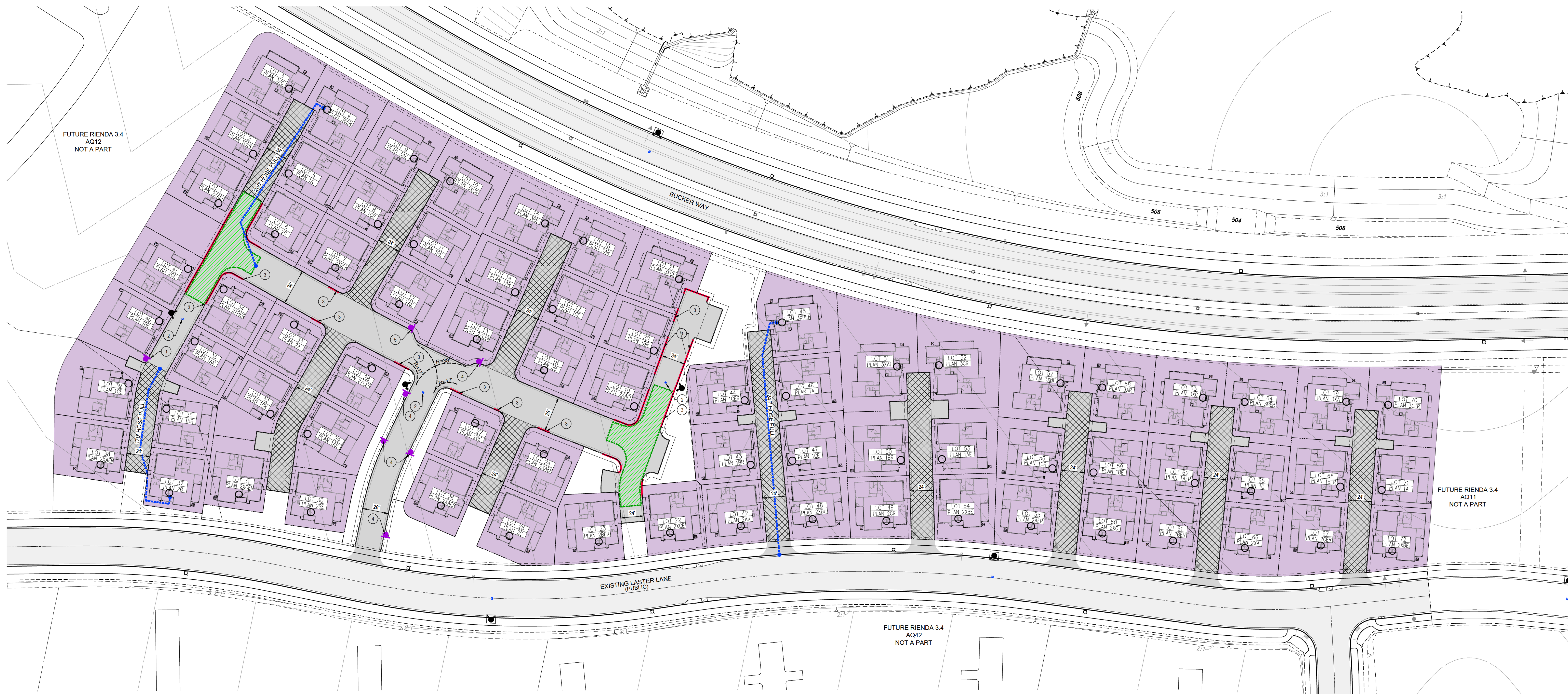

RANCH FIRE PROTECTION PROGRAM ATTACHMENTS

Ranch Plan Fire Protection Program was approved by Orange County Fire Authority and Orange County Board of Supervisors dated: July 31, 2007 and Amendment No. 1, dated: March 25, 2013; Amendment No. 2, dated: August 14, 2014 and Amendment No. 3, dated: March 31, 2022.

Attachments used with this submittal:
 3b Fire Lane No Parking Signs
 3c Begin / End Fire Lane Signs
 3g End of Fire Lane Identification
 3i Mounting Specifications for Fire Lane Signs and No Parking Signs
 3j Red Curb
 6a Street Widths
 10 Hydrant Distribution Table
 11 Fire Flow Requirement Table
 12a Fire Hydrant Locations
 12b Blue Dot Hydrant Marker Location

FIRE FLOW TEST REQUIREMENT

NOTE: A FIRE FLOW MODELING CALCULATION AND FIRE FLOW TEST SHALL BE COMPLETED AND OBTAINED FROM THE SANTA MARGARITA WATER DISTRICT PRIOR TO LUMBER DROP INSPECTION. THE FIRE FLOW TEST SHALL INDICATE THE FLOW AT 20 PSI, AND SHALL BE PROVIDED TO OCFA PRIOR TO SCHEDULING THE LUMBER DROP INSPECTION.

- CONSTRUCTION NOTES**
- INSTALL 'END OF FIRE ACCESS' SIGN PER DETAILS ON SHEET F-3.
 - INSTALL FIRE HYDRANT MARKER THAT SHALL BE PLACED 6" FROM CENTERLINE OF STREET.
 - INSTALL RED PAINTED CURB PER DETAILS ON SHEET F-3.
 - INSTALL 'FIRE LANE-NO PARKING' SIGN PER DETAILS ON SHEET F-3.
 - INSTALL 'END FIRE LANE-NO PARKING' SIGN PER DETAILS ON SHEET F-3.

BUILDING INFORMATION AND DATA

PLAN DESCRIPTION	STORIES	OCCUPANCY TYPE	CONSTRUCTION TYPE	AUTOMATIC FIRE SPRINKLERS	SQUARE FOOTAGE
BUILDING PLAN #1	2	R-3	V-B	NFPA 13D	1,540 SF
BUILDING PLAN #2	1	R-3	V-B	NFPA 13D	1,704 SF
BUILDING PLAN #2X	2	R-3	V-B	NFPA 13D	1,974 SF
BUILDING PLAN #3	1	R-3	V-B	NFPA 13D	1,723 SF
BUILDING PLAN #3X	2	R-3	V-B	NFPA 13D	2,187 SF

MIN. FIRE FLOW AND FIRE HYDRANT SPACING REQUIREMENTS

MINIMUM FIRE FLOW OF 1,000 GPM AT 20PSI FOR 1 HOUR REQUIRED PER THE LARGEST BUILDING OF APPROXIMATELY 2,187 SQ.FT. AND TYPE V-B CONSTRUCTION. A MINIMUM OF THREE (3) FIRE HYDRANTS ARE REQUIRED SPACED NO MORE THAN 600-FEET FROM HYDRANT TO HYDRANT, NO MORE THAN 300-FEET FROM ANY BUILDING, AND NO MORE THAN 250-FEET FROM THE END OF A DEAD-END FIRE ACCESS ROAD.

LEGEND

- EXISTING FIRE HYDRANT PER PREVIOUSLY APPROVED BACKBONE FIRE MASTER PLAN SR542339.
- PROPOSED PUBLIC FIRE HYDRANT WITH BLUE REFLECTIVE FIRE HYDRANT MARKER. MARKER SHALL BE PLACED 6" FROM CENTERLINE OF STREET.
- 4" MIN. UNIT ADDRESSING (SEE ARCHITECTURAL PLAN FOR FINAL DESIGN AND LOCATIONS)
- 300' HOSE PULL DISTANCE - FOR SINGLE FAMILY BUILDING TO THE FRONT DOOR.
- PAINT CURB RED WITH 'NO PARKING FIRE LANE' STENCIL AT 30" O.C. PER DETAILS HEREON AND OCFA GUIDELINE B-01
- INDICATES FIRE LANE-NO PARKING SIGN PER DETAILS HEREON AND THE RPPFP
- PROPOSED FIRE ACCESS ROAD WITH ALL-WEATHER PAVED SURFACE DESIGNED, AT A MINIMUM, TO THE AASHTO H-20 STANDARD PER THE RPPFP.
- EXISTING FIRE ACCESS ROAD
- NOT A PART OF FIRE ACCESS BUT DRIVE WILL BE CONSTRUCTED WITH ALL-WEATHER PAVED SURFACE DESIGNED, AT A MINIMUM, TO THE AASHTO H-20 STANDARD PER THE RPPFP.
- INDICATES PROPOSED STRUCTURES MEETING THE 2022 CALIFORNIA RESIDENTIAL CODE SECTION R337
- INDICATES FIRE APPARATUS TURNING RADIUS: 20' WIDE PATH WITH 17" INSIDE AND 36" OUTSIDE
- LOT # | UNIT # | PLAN TYPE

NO.	DATE	REVISIONS
1		
2		
3		
4		

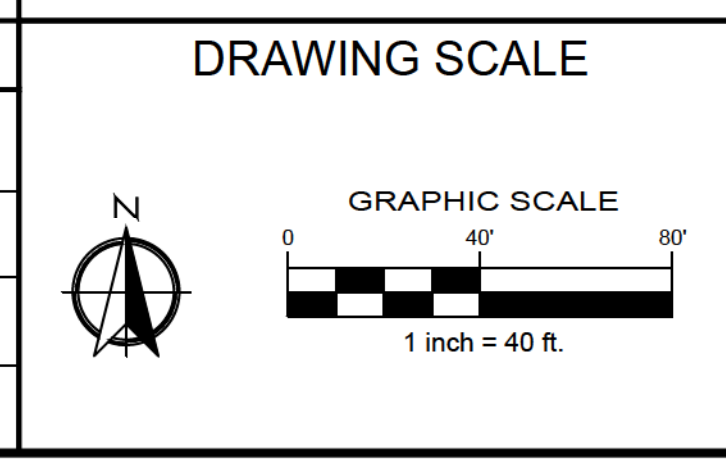

CIVIL ENGINEER:

AS
 ADAMS STREETER
 Civil Engineers
 16755 VON KARMAN, STE. 150
 IRVINE, CA 92606

ARCHITECTURE/PLANNING:

WHA
 ARCHITECTS - PLANNERS - DESIGNERS
 680 NEWPORT CENTER DRIVE, SUITE 300
 NEWPORT BEACH, CA 92660

PREPARED BY:

firesafe
 PLANNING, INC.
 28506 AIROSO STREET
 RANCHO MISSION VIEJO, CA 92694
 (949) 240-5911

PREPARED FOR:

LENNAR
 5000 FIVEPOINT, 3RD FLOOR
 IRVINE, CA 92618
 (949) 349-8000

PREPARED FOR:

RMV PA3 DEVELOPMENT, LLC
 28811 ORTEGA HIGHWAY
 SAN JUAN CAPISTRANO, CA 92675
 (949) 240-3363

TITLE:

**FIRE MASTER PLAN
 RANCHO MISSION VIEJO
 RIENDA PA 3.4
 AQ22 VTTM 19306
 OCFA SR 544565**

ORANGE COUNTY FIRE AUTHORITY

DATE: 03/05/2024
 SHEET: **F-2**
 2 OF 3



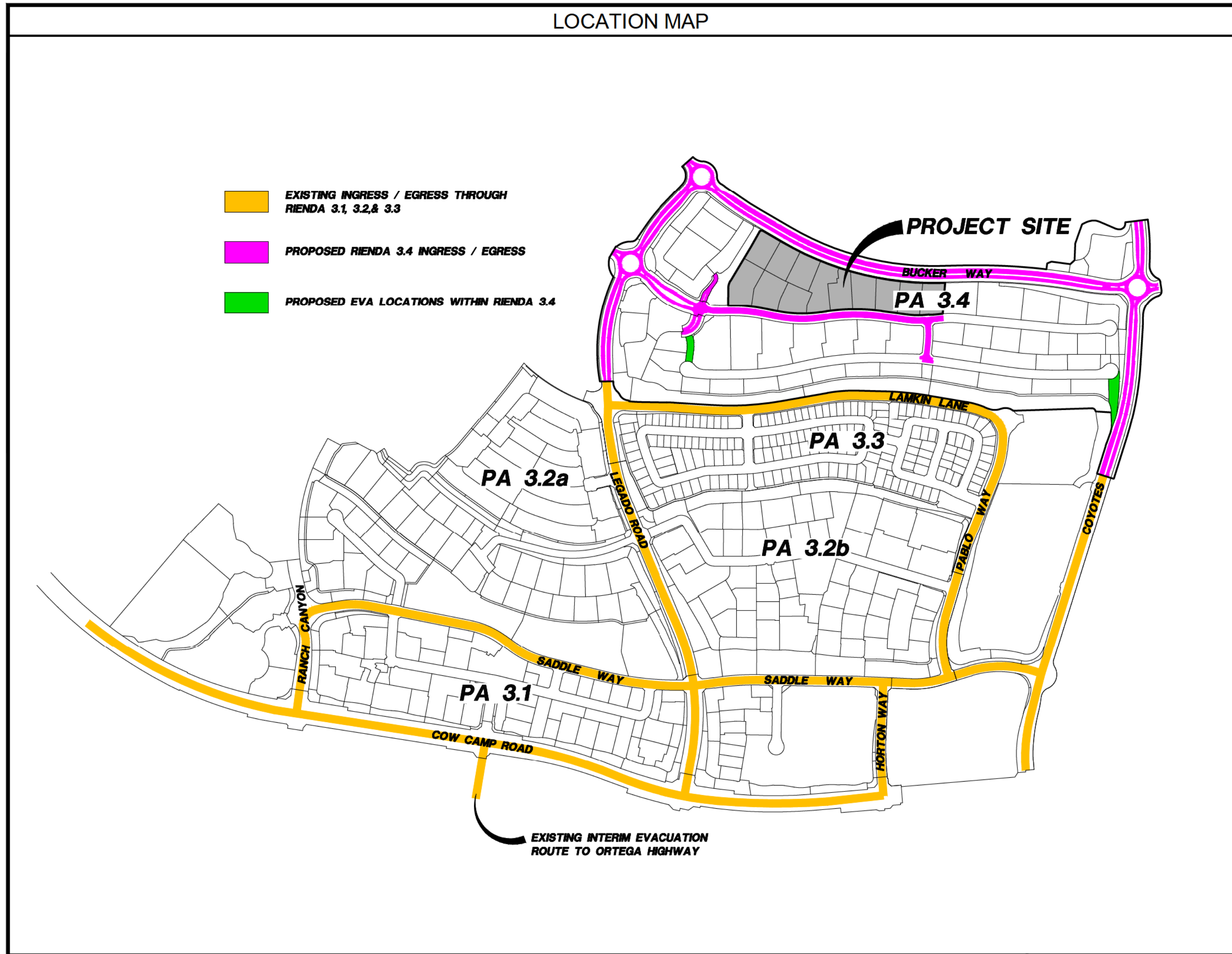

FIRE ACCESS ROADWAY CERTIFICATION LETTER

AS
ADAMS STREETER
Civil Engineers

November 20, 2023

Subject: RMV - Rienda 3.4 AQ22 - Fire Access Roadway Certification

To Whom It May Concern:

This letter is provided to certify that the fire access roadways, including any underground vaults, culverts and other features beneath fire access roadways for the Rienda 3.4, AQ22, VTTM 19306 are designed to provide all-weather driving capabilities, at a minimum, to the American Association of State Highway and Transportation Officials H-20 standard. The Fire access roadways are also designed with a maximum grade of no greater than 10%.

Sincerely,
N. Streeter
Nicholas A. Streeter, PE, PLS
Senior Vice President
NStreeter@adams-streeter.com

REGISTERED PROFESSIONAL ENGINEER
NICHOLAS A. STREETER
C 70862
CIVIL
STATE OF CALIFORNIA

16755 Von Karman Avenue, Suite 150, Irvine, CA 92606 | 949.474.2330 | adams-streeter.com

PARKING ENFORCEMENT LETTER

MARCH 5, 2024

PLANNING AND DEVELOPMENT SERVICES SECTION
ORANGE COUNTY FIRE AUTHORITY
1 FIRE AUTHORITY ROAD
IRVINE, CA 92602

RE: RIENDA PA3.4 AQ22 FIRE MASTER PLAN, VESTING TENTATIVE TRACT NO. 19306, RANCHO MISSION VIEJO, COUNTY OF ORANGE, CA. OCFA SERVICE REQUEST NUMBER 544565 PARKING ENFORCEMENT PLAN

THE FIRE LANE PARKING ENFORCEMENT PLAN FOR THE ABOVE REFERENCED PROJECT IS STATED AS FOLLOWS:

ALL FIRE LANES WITHIN PROJECT SHALL BE MAINTAINED AND IN NO EVENT SHALL PARKING BE PERMITTED ALONG ANY PORTION OF A STREET OR DRIVE THAT REQUIRED FIRE LANES OR ANY AREA DESIGNATED AS A FIRE LANE FOR TURN-AROUND OR DRIVE THROUGH PURPOSES.

PROJECT HOMEOWNER'S ASSOCIATION SHALL ADOPT REASONABLE RULES AND REGULATIONS REGARDING THE PARKING OF VEHICLES ALONG THE STREETS, ROADS AND OR DRIVES WITHIN THE PROJECT THAT ARE NOT IN CONFLICT WITH APPLICABLE LAW.

IN FURTHERANCE THEREOF, PROJECT HOMEOWNER'S ASSOCIATION, THROUGH ITS OFFICERS, COMMITTEES AND AGENTS WILL ESTABLISH THE "PARKING" AND "NO PARKING" AREAS WITHIN THE PROPERTY IN ACCORDANCE WITH SECTION 22658.2 OF THE CALIFORNIA VEHICLE CODE AND THE RANCH FIRE PROTECTION PROGRAM. THE LAW SHALL BE ENFORCED THROUGH SUCH RULES AND REGULATIONS BY ALL LAWFUL MEANS, INCLUDING, WRITTEN WARNINGS, CITING, LEVYING FINES AND TOWING VEHICLES IN VIOLATION.

PROJECT HOMEOWNER'S ASSOCIATION WILL CONTRACT WITH A CERTIFIED PATROL AND TOWING COMPANY TO REMOVE VEHICLES THAT VIOLATE NO PARKING RESTRICTIONS. FIRST TIME VIOLATORS WILL RECEIVE A WRITTEN WARNING AND WITH SUBSEQUENT VIOLATIONS, THE VEHICLE SHALL BE SUBJECT TO TOWING. THE VEHICLE OWNER SHALL BE RESPONSIBLE FOR ALL COSTS INCURRED IN REMEDYING SUCH VIOLATION, INCLUDING WITHOUT LIMITATION TOWING COST, CITATIONS AND LEGAL FEES.

COMBUSTIBLE CONSTRUCTION LETTER

MARCH 5, 2024
ORANGE COUNTY FIRE AUTHORITY
1 FIRE AUTHORITY ROAD
IRVINE, CA 92602-0125

SUBJECT: COMBUSTIBLE CONSTRUCTION LETTER: RIENDA PA3.4 AQ22 FIRE MASTER PLAN - OCFA S.R. 544565 RANCHO MISSION VIEJO, COUNTY OF ORANGE

THE PURPOSE OF THIS LETTER IS TO NOTIFY YOU THAT THIS PROJECT SHALL INSTALL ALL REQUIRED PAVED FIRE ACCESS ROADS THAT MEET O.C.F.A. GUIDELINES PER THE APPROVED PLANS. ALL FIRE HYDRANTS AND WATER SUPPLY FOR FIREFIGHTING PURPOSES SHALL BE INSTALLED PER THE APPROVED PLANS AND SHALL MEET ALL FIRE FLOWS REQUIREMENTS, PRIOR TO ANY COMBUSTIBLE CONSTRUCTION MATERIALS BEING DELIVERED FOR CONSTRUCTION.

FIRE LANE PARKING SIGN DETAILS

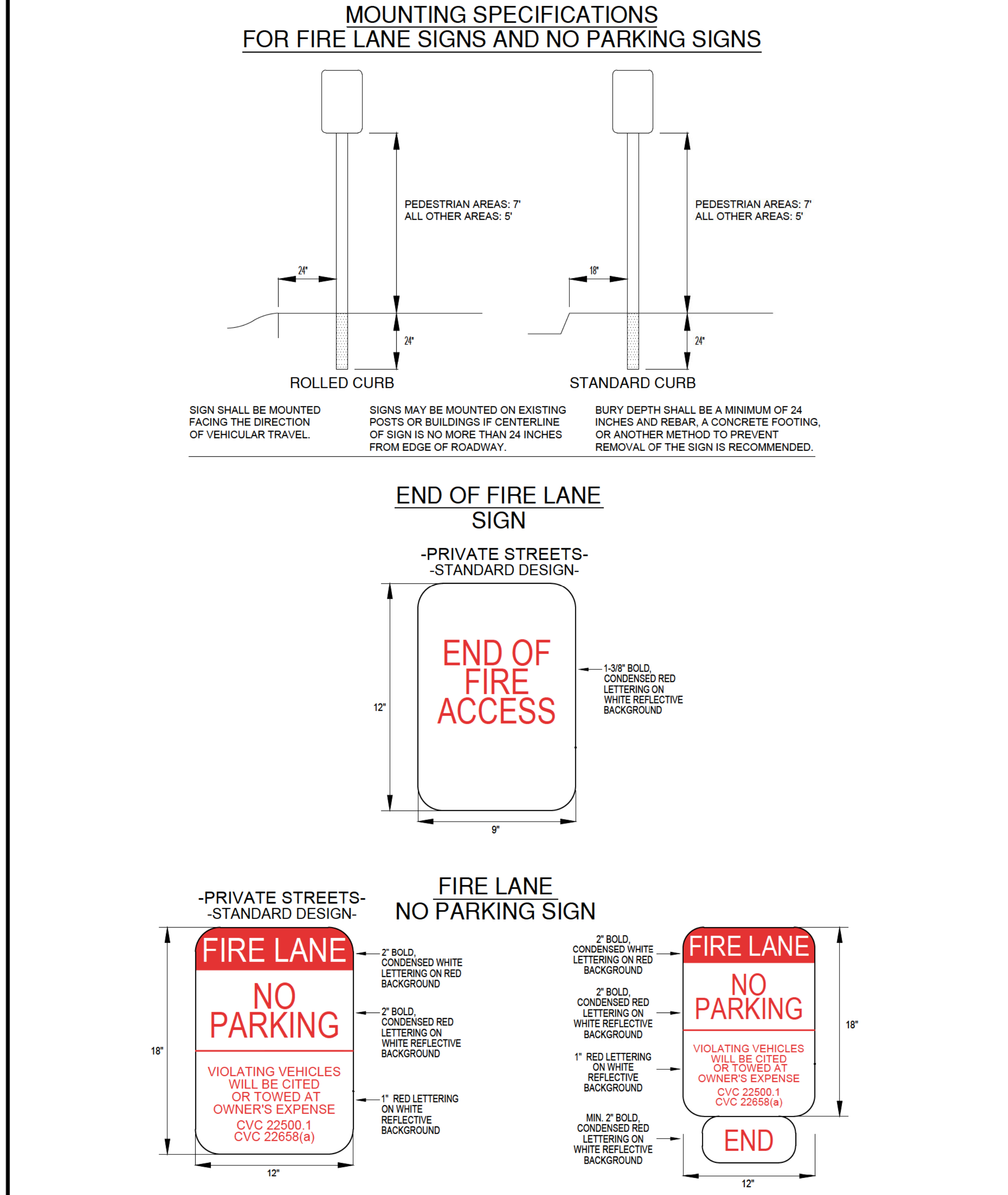

ELEVATIONS



STREET SECTIONS

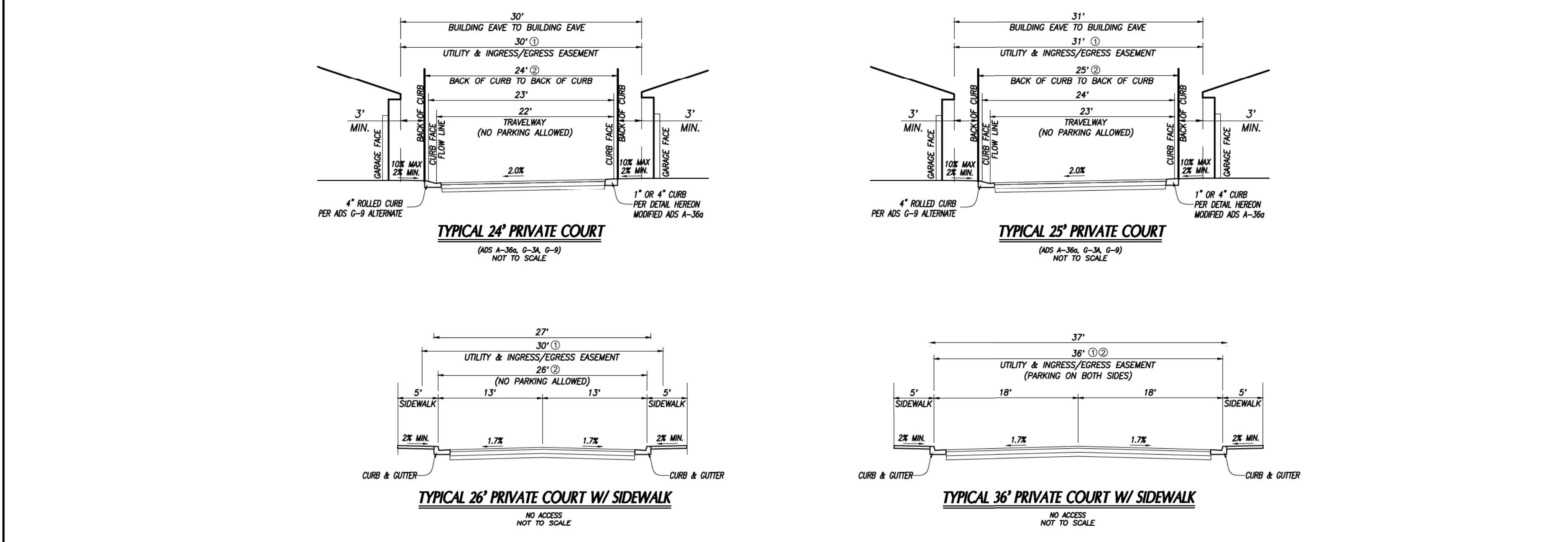

FIRE LINE RED CURB DETAILS

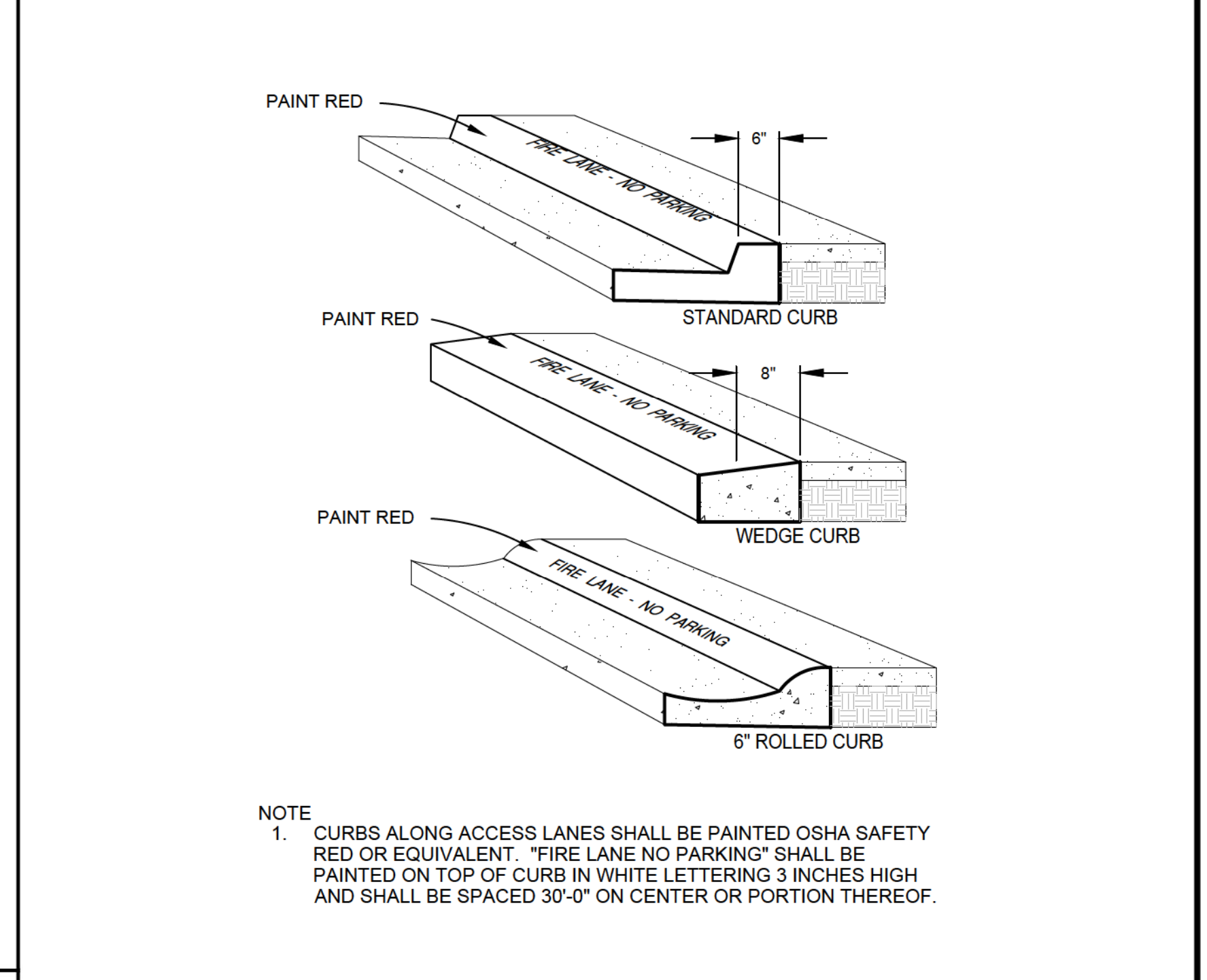

NOTE
1. CURBS ALONG ACCESS LANES SHALL BE PAINTED OSHA SAFETY RED OR EQUIVALENT. "FIRE LANE NO PARKING" SHALL BE PAINTED ON TOP OF CURB IN WHITE LETTERING 3 INCHES HIGH AND SHALL BE SPACED 30'-0\"/>

NO.	DATE	REVISIONS
1		
2		
3		
4		

CIVIL ENGINEER:
AS
ADAMS STREETER
Civil Engineers
16755 VON KARMAN, STE. 150
IRVINE, CA 92606

ARCHITECTURE-PLANNING:
WHA
680 NEWPORT CENTER DRIVE, SUITE 300
NEWPORT BEACH, CA 92660

PREPARED BY:
firesafe
PLANNING, INC.
28506 AIROSO STREET
RANCHO MISSION VIEJO, CA 92694
(949) 240-5811

PREPARED FOR:
LENNAR
5000 FIVEPOINT, 3RD FLOOR
IRVINE, CA 92618
(949) 349-8000

PREPARED FOR:
RMV PA3
DEVELOPMENT, LLC
28811 ORTEGA HIGHWAY
SAN JUAN CAPISTRANO, CA 92675
(949) 240-3363

TITLE:
FIRE MASTER PLAN
RANCHO MISSION VIEJO
RIENDA PA 3.4
AQ22 VTTM 19306
OCFA SR 544565
ORANGE COUNTY FIRE AUTHORITY

DATE:
03/05/2024

SHEET:
F-3
3 OF 3



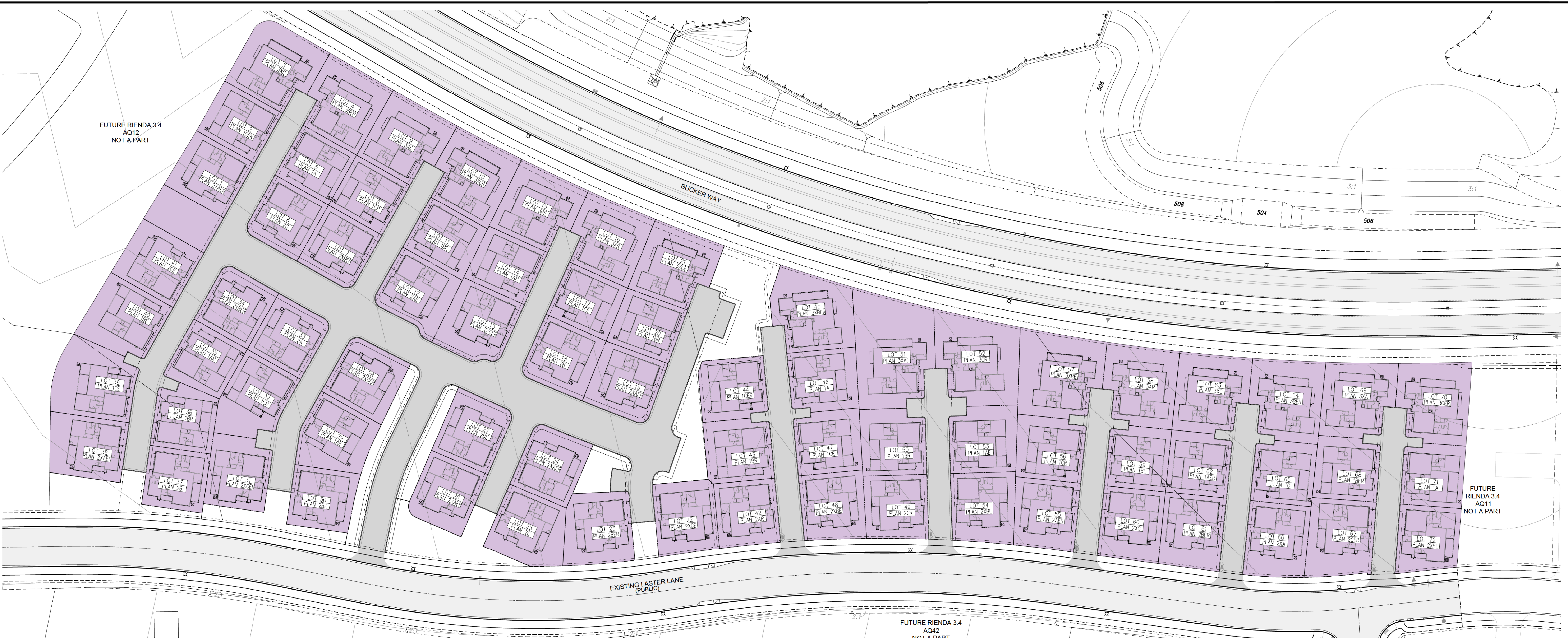

CALIFORNIA RESIDENTIAL CODE SECTION R337 SCREENING FORM
Fire Protection Plan 2022 CBC Chapter 7A Screening Form

CBC Chapter 7A Code Section	Yes	No
700A 1 General	X	
700A 2 Qualifications by Testing	X	
700A 3 Approved Agency	X	
700A 4 Labeling	X	
700A 5 700A.5.1 & 700A.5.2 Weathering and surface treatment protection	X	
700A 5.2.1 Fire-retardant-treated wood	X	
700A 5.2.2 Fire-retardant-treated wood shingles and shakes	X	
700A 5.3 Surface treatment protection	X	
700A 6 Alternate materials design, details methods of construction	X	
700A 7 Standards of Quality	X	
700A & 700A.1 Ignition-Resistant Construction & General	X	
700A.2 Ignition-Resistant Material	X	
700A.3 Conditions of acceptance for ignition-resistant material	X	
700A.4 Fire testing of wood structural panels	X	
700A.4 Alternate methods for determining ignition-resistant material	X	
700A & 700A.1 Roofing & Roofing General	X	
700A.3 Roof Coverings	X	
700A.3 Roof Valleys	X	
700A.3 Roof Gutters	X	
700A & 700A.1 Vents & Vents General	X	
700A.2 Vents Requirements	X	
700A.2 Off ridge and ridge vents	X	
700A, 700A.1 & 700A.2 Exterior Coverings: Schemes & General	X	
700A.3 Exterior Wall Coverings	X	
700A.3 Extent of Exterior Wall Coverings	X	
700A.4 & 700A.4.1 Exterior Wall Assemblies & Conditions of Acceptance	X	
700A.5 Open Roof Eaves	X	
700A.6 Enclosed Roof Eaves and Roof Eave soffits	X	
700A.7 Exterior Porch Ceilings	X	
700A.8 Floor Projections	X	
700A.9 Underlath Protection	X	
700A.10 Underlath of Appendages	X	
700A.11 Conditions of acceptance when tested in accordance with ASTM E2657	X	
700A & 700A.1 Exterior Windows, Skylights and Doors & General	X	
700A.2 Exterior glazing	X	
700A.1 Exterior Windows, Skylights and exterior glazed door assembly requirements	X	
700A.2 Operable Skylights	X	
700A.2.3 Structural glass veneer	X	
700A.3 Exterior Doors	X	
700A.3.1 Exterior Door Glazing	X	
700A.4 Garage Door Penetrator Gap	X	
700A, 700A.1 & 700A.1.1 Decking, General & Flashing	X	
700A.2 Where required	X	
700A.3 Locking Surfaces	X	
700A.4 Requirements of type of ignition-resistant material in Section 700A.3, Item 1	X	
700A.4.1 Conditions of acceptance for ASTM E2632	X	
700A.4.2 Conditions of acceptance for ASTM E2726	X	
700A.4.3 Requirements for type of material in Section 700A.3, Item 2	X	
700A & 700A.1 Accessory Buildings and Miscellaneous Structures & General	X	
710A.1 Applicability	X	
710A.3 Where required	X	
710A.3.1 Structures and Accessory Buildings within 3 feet	X	
710A.3.2 Accessory Buildings greater than 120 sq ft, located 3 feet or more but less than 50 feet	X	
710A.3.3 Accessory Buildings 120 sq ft, or less, located 3 feet or more but less than 50 feet	X	
710A.3.4 Miscellaneous Structures located 3 feet or more but less than 50 feet	X	
710A.4 Roof Construction	X	

LOCATION MAP

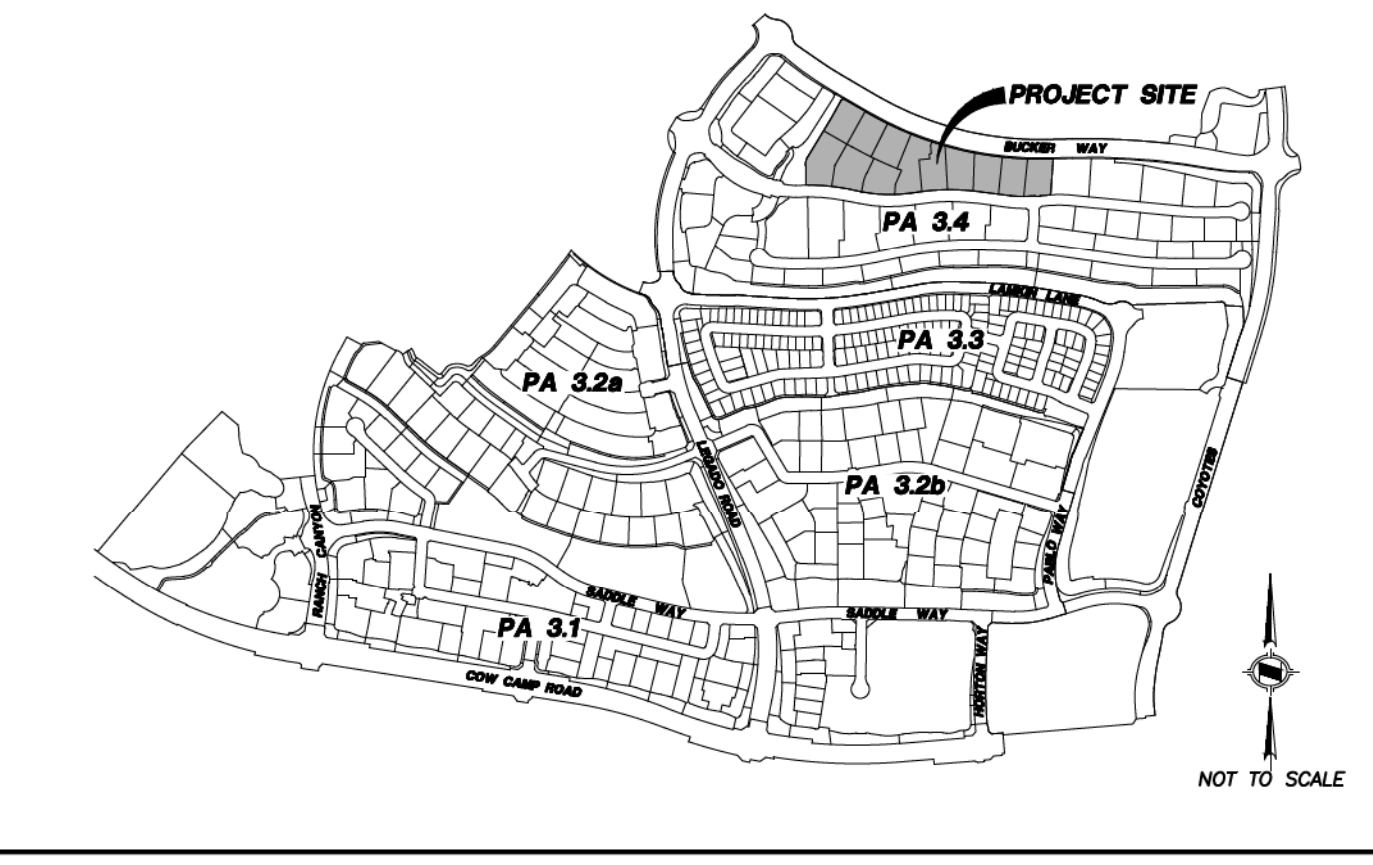

OCFA APPROVAL

ORANGE COUNTY FIRE AUTHORITY
 Reviewed by Planning & Development
 Service Request Expires After 6 Months of Inactivity
 Approval subject to field inspection and required test, notations hereon, conditions in correspondence and conformance with applicable regulations. The stamping of these plans shall not be held to permit or approve the violation of any law.
 OCFA SR #: 544564
 Fee Codes: PR146
 Plan Type: Fire Protection Plan
 By: shawnfraley
 Date: 04/30/2024
 ONLY STAMPED SHEETS REVIEWED BY ORANGE COUNTY FIRE AUTHORITY
 Call at least 72 hours in advance to schedule inspections: (714) 573-6150
 Notes:

SYMBOL LEGEND

LOT #	UNIT #	PLAN TYPE
-------	--------	-----------

NO.	DATE	REVISIONS
1		
2		
3		
4		

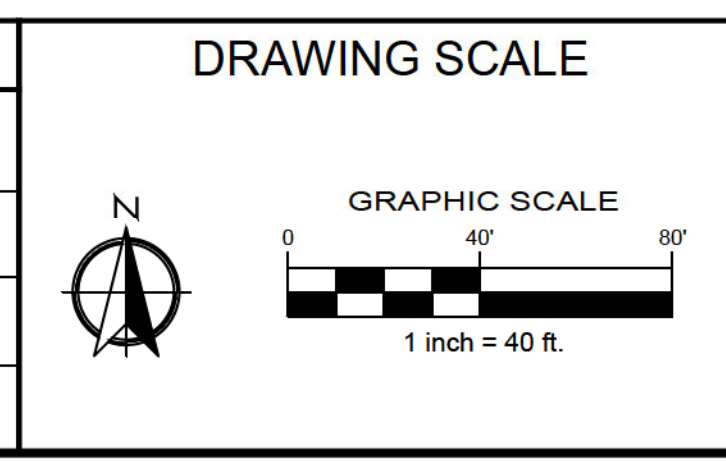

CIVIL ENGINEER:

ADAMS STREETER
 Civil Engineers
 16755 VON KARMAN, STE. 150
 IRVINE, CA 92606

ARCHITECTURE/PLANNING:
 ARCHITECTS - PLANNERS - DESIGNERS

WHA
 680 NEWPORT CENTER DRIVE, SUITE 300
 NEWPORT BEACH, CA 92660

PREPARED BY:

firesafe
 PLANNING, INC.
 28506 AIROSO STREET
 RANCHO MISSION VIEJO, CA 92694
 (949) 240-5911

PREPARED FOR:

LENNAR
 5000 FIVEPOINT, 3RD FLOOR
 IRVINE, CA 92618
 (949) 349-8000

PREPARED FOR:

RMV PA3 DEVELOPMENT, LLC
 28811 ORTEGA HIGHWAY
 SAN JUAN CAPISTRANO, CA 92675
 (949) 240-3363

TITLE: **FIRE PROTECTION PLAN**
RANCHO MISSION VIEJO
RIENDA PA 3.4
AQ22 VTTM 19306
OCFA SR 544564
 ORANGE COUNTY FIRE AUTHORITY

DATE: 03/05/2024
 SHEET: **F-1**
 1 OF 1