

# VESTING TENTATIVE TRACT MAP NO. 17522 COUNTY OF ORANGE

LOT AREA TABLE				LOT AREA TABLE							
LOT NO.	GROSS AREA (ACRES)	NET AREA (ACRES)	PERCENT (%)	LOT NO.	GROSS AREA (ACRES)	NET AREA (ACRES)	PERCENT (%)				
1	15,479	0.36	101	22,333	0.51	201	17,852	0.41	301	19,487	0.45
2	12,240	0.28	102	22,851	0.52	202	18,378	0.42	302	14,908	0.34
3	13,834	0.32	103	24,279	0.56	203	22,421	0.51	303	18,111	0.42
4	17,025	0.39	104	26,823	0.61	204	15,534	0.36	304	21,382	0.49
5	12,332	0.28	105	20,546	0.47	205	15,539	0.35	305	21,085	0.48
6	11,172	0.26	106	20,856	0.48	206	12,313	0.28	306	21,639	0.50
7	11,889	0.27	107	18,115	0.41	207	16,692	0.38	307	17,032	0.39
8	13,899	0.32	108	22,163	0.51	208	15,534	0.36	308	22,210	0.51
9	12,266	0.28	109	24,067	0.55	209	14,196	0.33	309	20,141	0.46
10	15,851	0.36	110	17,588	0.40	210	14,196	0.33	310	15,213	0.35
11	14,684	0.34	111	18,032	0.41	211	14,172	0.33	311	14,963	0.34
12	13,807	0.32	112	16,231	0.37	212	20,080	0.46	312	17,702	0.39
13	11,291	0.27	113	14,860	0.34	213	14,529	0.33	313	17,460	0.40
14	11,938	0.27	114	12,114	0.28	214	17,979	0.41	314	19,550	0.45
15	15,712	0.36	115	12,039	0.28	215	15,789	0.36	315	17,560	0.40
16	12,029	0.28	116	17,842	0.40	216	17,074	0.41	316	14,692	0.34
17	11,559	0.27	117	14,017	0.32	217	15,024	0.33	317	13,219	0.30
18	9,804	0.23	118	12,582	0.29	218	20,139	0.46	318	16,729	0.38
19	10,296	0.25	119	17,180	0.39	219	15,024	0.33	319	12,922	0.30
20	10,738	0.25	120	24,214	0.55	220	12,469	0.29	320	12,110	0.28
21	11,114	0.26	121	20,438	0.46	221	25,594	0.58	321	20,228	0.47
22	10,561	0.24	122	14,791	0.34	222	12,045	0.28	322	22,159	0.51
23	10,983	0.25	123	13,628	0.31	223	12,322	0.28	323	18,498	0.42
24	10,969	0.25	124	14,984	0.32	224	16,864	0.37	324	19,447	0.45
25	13,632	0.31	125	13,708	0.31	225	29,746	0.67	325	20,181	0.46
26	21,881	0.50	126	12,721	0.29	226	10,524	0.24	326	20,536	0.47
27	21,685	0.50	127	16,257	0.37	227	13,047	0.30	327	15,469	0.36
28	21,529	0.50	128	23,810	0.55	228	13,026	0.30	328	16,831	0.39
29	20,521	0.47	129	14,722	0.33	229	16,759	0.38	329	23,472	0.54
30	20,212	0.46	130	12,223	0.28	230	12,594	0.29	330	20,228	0.47
31	20,950	0.48	131	15,739	0.35	231	12,643	0.29	331	20,173	0.46
32	21,138	0.49	132	13,654	0.31	232	12,624	0.29	332	17,258	0.41
33	15,505	0.36	133	13,158	0.31	233	12,817	0.29	333	18,229	0.42
34	15,927	0.37	134	12,721	0.29	234	13,887	0.32	334	19,320	0.45
35	18,417	0.43	135	15,016	0.34	235	13,281	0.30	335	13,888	0.32
36	21,312	0.49	136	14,558	0.34	236	16,307	0.37	336	15,510	0.35
37	21,318	0.49	137	22,231	0.51	237	18,147	0.41	337	18,079	0.41
38	19,082	0.44	138	21,288	0.50	238	18,729	0.43	338	23,473	0.54
39	15,827	0.36	139	14,017	0.32	239	17,029	0.39	339	19,754	0.45
40	15,301	0.35	140	14,074	0.32	240	15,979	0.37	340	18,602	0.43
41	17,884	0.41	141	12,670	0.29	241	15,683	0.36	341	16,013	0.37
42	19,119	0.44	142	12,936	0.30	242	14,882	0.34	342	12,639	0.29
43	15,919	0.36	143	12,721	0.29	243	15,807	0.36	343	19,320	0.45
44	15,617	0.36	144	13,055	0.30	244	16,098	0.37	344	10,636	0.24
45	15,810	0.36	145	14,085	0.32	245	15,586	0.36	345	16,029	0.37
46	20,498	0.47	146	18,769	0.45	246	14,332	0.33			
47	14,237	0.33	147	16,808	0.39	247	15,862	0.36			
48	14,433	0.33	148	16,815	0.40	248	16,815	0.38			
49	17,206	0.41	149	25,437	0.58	249	25,135	0.58			
50	13,835	0.32	150	29,856	0.69	250	14,572	0.33			
51	28,120	0.65	151	10,288	0.23	251	15,129	0.35			
52	23,212	0.53	152	14,017	0.32	252	15,524	0.35			
53	12,265	0.28	153	15,180	0.35	253	12,290	0.28			
54	11,806	0.27	154	15,512	0.36	254	28,889	0.66			
55	10,872	0.25	155	18,336	0.43	255	12,721	0.29			
56	12,338	0.29	156	18,336	0.43	256	16,263	0.37			
57	16,562	0.38	157	14,677	0.33	257	18,143	0.42			
58	18,889	0.43	158	14,702	0.34	258	18,713	0.43			
59	22,434	0.52	159	18,320	0.42	259	18,024	0.41			
60	16,252	0.37	160	15,374	0.35	260	16,616	0.38			
61	13,664	0.31	161	15,809	0.36	261	14,855	0.34			
62	12,571	0.28	162	21,425	0.49	262	14,840	0.34			
63	11,234	0.27	163	18,757	0.43	263	14,536	0.33			
64	11,884	0.27	164	12,280	0.28	264	14,276	0.32			
65	11,824	0.27	165	16,442	0.38	265	13,277	0.30			
66	12,829	0.31	166	13,538	0.31	266	12,696	0.29			
67	16,885	0.39	167	15,570	0.35	267	14,364	0.33			
68	16,783	0.39	168	15,111	0.35	268	12,288	0.28			
69	16,562	0.39	169	15,498	0.36	269	17,489	0.40			
70	16,504	0.39	170	20,930	0.48	270	12,123	0.28			
71	16,539	0.39	171	18,383	0.42	271	14,852	0.33			
72	16,863	0.39	172	17,616	0.40	272	14,526	0.32			
73	17,283	0.40	173	21,629	0.50	273	18,571	0.43			
74	19,897	0.46	174	17,434	0.40	274	15,563	0.35			
75	16,129	0.37	175	14,126	0.32	275	14,448	0.33			
76	15,594	0.36	176	28,727	0.66	276	18,559	0.45			
77	17,115	0.39	177	14,252	0.33	277	19,291	0.45			
78	18,128	0.42	178	14,395	0.33	278	17,278	0.40			
79	20,212	0.46	179	16,712	0.38	279	17,596	0.41			
80	17,452	0.40	180	25,345	0.58	280	19,715	0.45			
81	16,102	0.37	181	23,067	0.53	281	17,225	0.40			
82	15,233	0.35	182	20,821	0.47	282	14,288	0.32			
83	15,556	0.36	183	14,814	0.34	283	14,828	0.34			
84	14,376	0.33	184	13,656	0.31	284	21,262	0.49			
85	13,862	0.32	185	13,844	0.32	285	15,614	0.36			
86	11,270	0.27	186	15,128	0.35	286	15,229	0.36			
87	15,556	0.36	187	14,814	0.34	287	14,828	0.34			
88	15,647	0.36	188	13,656	0.31	288	18,286	0.43			
89	14,059	0.32	189	13,165	0.30	289	22,586	0.51			
90	15,340	0.35	190	13,031	0.30	290	20,029	0.47			
91	17,863	0.41	191	12,548	0.29	291	20,727	0.47			
92	18,274	0.43	192	24,118	0.55	292	23,459	0.54			
93	13,529	0.31	193	31,489	0.72	293	10,607	0.24			
94	13,425	0.31	194	34,179	0.78	294	18,023	0.41			
95	16,328	0.37	195	13,128	0.30	295	20,428	0.47			
96	18,295	0.43	196	11,828	0.28	296	18,609	0.43			
97	18,364	0.43	197	14,745	0.34	297	16,348	0.38			
98	20,029	0.46	198	15,881	0.36	298	14,732	0.34			
99	21,178	0.49	199	15,542	0.36	299	15,689	0.36			
100	22,023	0.51	200	18,601	0.43	300	18,273	0.42			

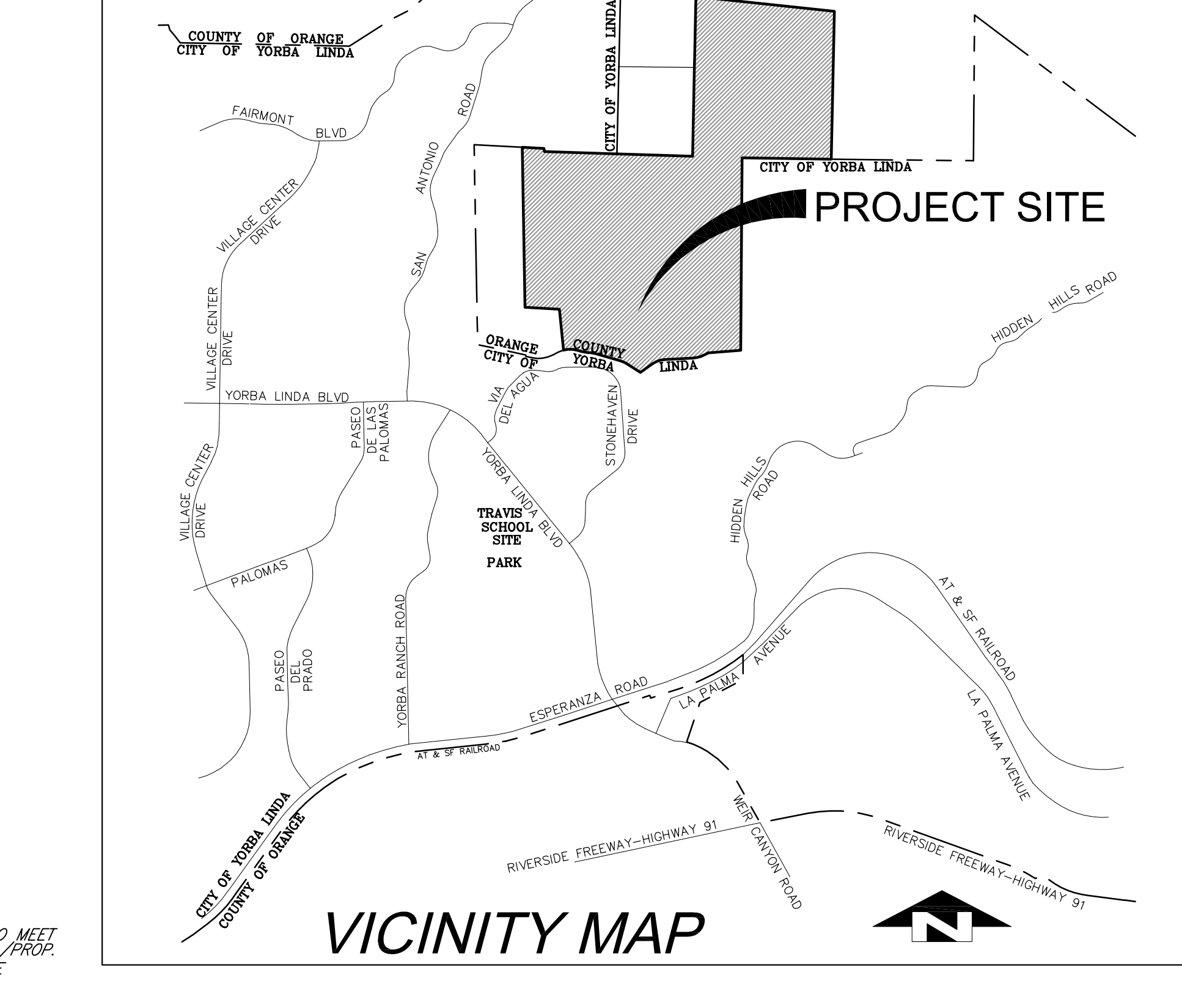
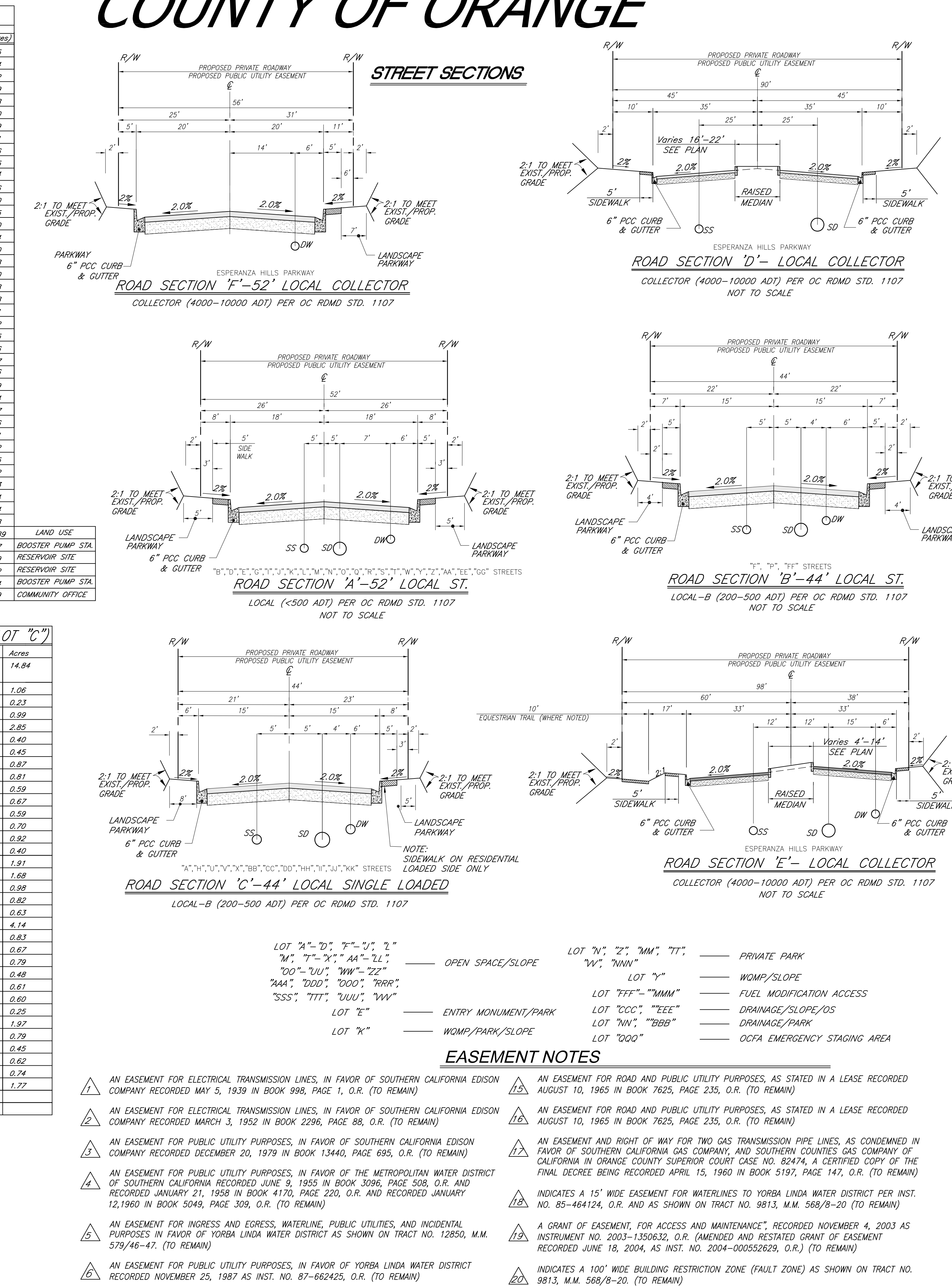

LOT SUMMARY TABLE		
LOT NO.	LAND USE	RESIDENTIAL LOTS (RSF)
338	RESIDENTIAL LOTS (RSF)	
339	ESTATE LOT	
340	ESTATE LOT	
341	Y/LWO 1390 ZONE BOOSTER PUMP STATION	
342	Y/LWO 1200 ZONE RESERVOIR SITE	
343	Y/LWO 1500 ZONE RESERVOIR SITE	
344	Y/LWO 1390 ZONE BOOSTER PUMP STATION	
345	COMMUNITY OFFICE	

PROJECT TOTAL		
BOUNDARY	SF	ACRES
	20,426,843	468.9

**APPLICANT/SUBDIVIDER INFORMATION**  
 YORBA LINDA ESTATES, LLC  
 7114 EAST STETSON DRIVE, SUITE 350  
 SCOTTSDALE, AZ 85251  
 (480) 985-8910  
 CONTACT: DOUG WYNORE

**ENGINEER INFORMATION**  
 CA ENGINEERING  
 13821 NEWPORT AVE., STE. 110  
 SCOTTSDALE, AZ 85251  
 PHONE: (949) 724-9180  
 CONTACT: FRED CORNWELL, P.E.

**PROPERTY OWNERSHIP INFORMATION**  
 APN# 351-031-006  
 YORBA LINDA ESTATES, LLC  
 550 KATHERINE AVE.  
 SCOTTSDALE, AZ 85251  
 OAK VIEW, CA 93022

**LEGAL DESCRIPTION**  
 THE LAND REFERRED TO BELOW IS SITUATED IN THE COUNTY OF ORANGE, STATE OF CALIFORNIA, AND IS DESCRIBED AS FOLLOWS:  
 APN# 351-031-006 (YORBA LINDA ESTATES, LLC)  
 THAT PORTION OF THE LAND ALLOTTED TO M.W. DE SHOR IN THE DECREE OF PARTITION OF THE RANCHO CANON DE SANTA ANA RENDERED IN THE CASE NO. 1978 OF THE 17TH JUDICIAL DISTRICT COURT OF CALIFORNIA, A CERTIFIED COPY OF WHICH WAS RECORDED FEBRUARY 8, 1974 IN BOOK 28, PAGE 158 OF DEEDS OF LOS ANGELES COUNTY, CALIFORNIA, AND LOCATED IN THE COUNTY OF ORANGE, STATE OF CALIFORNIA.  
 APN# 326-031-006 (JOHN JAY NICHOLAS TRUST (YORBA LINDA ESTATES NORTH, LLC, OPTION TO BUY))  
 JOHN JAY NICHOLAS TRUST (YORBA LINDA ESTATES NORTH, LLC, OPTION TO BUY)  
 550 KATHERINE AVE.  
 SCOTTSDALE, AZ 85251  
 OAK VIEW, CA 93022

**BASIS OF BEARINGS**  
 THE BEARINGS SHOWN HEREON ARE BASED ON THE GRID BEARING BETWEEN O.C.S. HORIZONTAL CONTROL STATION 10, 5186.20, GPS NO. 8163, BEING N.71°02'12"E. PER RECORDS ON FILE IN THE OFFICE OF THE COUNTY SURVEYOR.

**BENCH MARK**  
 O.C. B.M. #21-53-83 STD. O.C.S.B.M. DISC ABOUT 36 FT. NORTH OF THE CENTERLINE OF ESPERANZA RD., ABOUT 660 FT. EAST OF THE WE



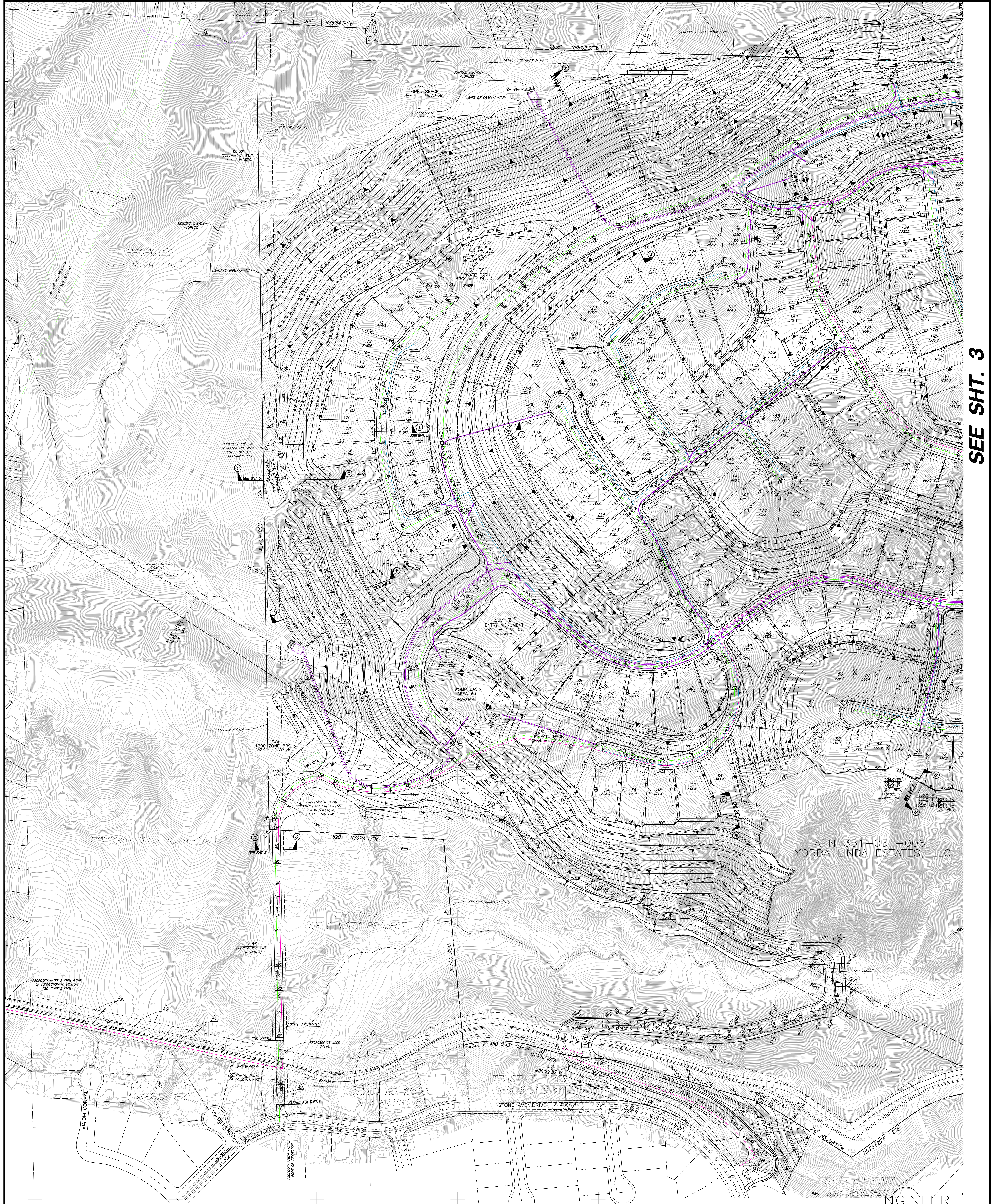

SEE SH. 3

APN 351-031-006  
YORBA LINDA ESTATES, LLC

ENGINEER

**UTILITY LEGEND:**

(Blue)	PROPOSED WATER (TRANSMISSION)
(Cyan)	PROPOSED WATER (DISTRIBUTION)
(Green)	PROPOSED SEWER
(Green Dashed)	PROPOSED STORM DRAIN
(Cyan Dashed)	EXISTING WATER
(Green Dashed)	EXISTING SEWER
(Red Dashed)	EXISTING STORM DRAIN

FRED CORNWELL

**CA ENGINEERING, INC.**  
**Planning • Engineering • Surveying**  
 13821 NEWPORT AVE., STE 110  
 TUSTIN, CALIF. 92780  
 (949) 724-9480 (949) 724-9484 FAX

VESTING TENTATIVE TRACT MAP  
 MAP NO. 17522  
 ESPERANZA HILLS  
 COUNTY OF ORANGE, CALIFORNIA

DATE: \_\_\_\_\_

DATE: **Apr 27 2018**

SHEET: **2**

OF: **6**



SEE SHT. 4

SEE SHT. 2

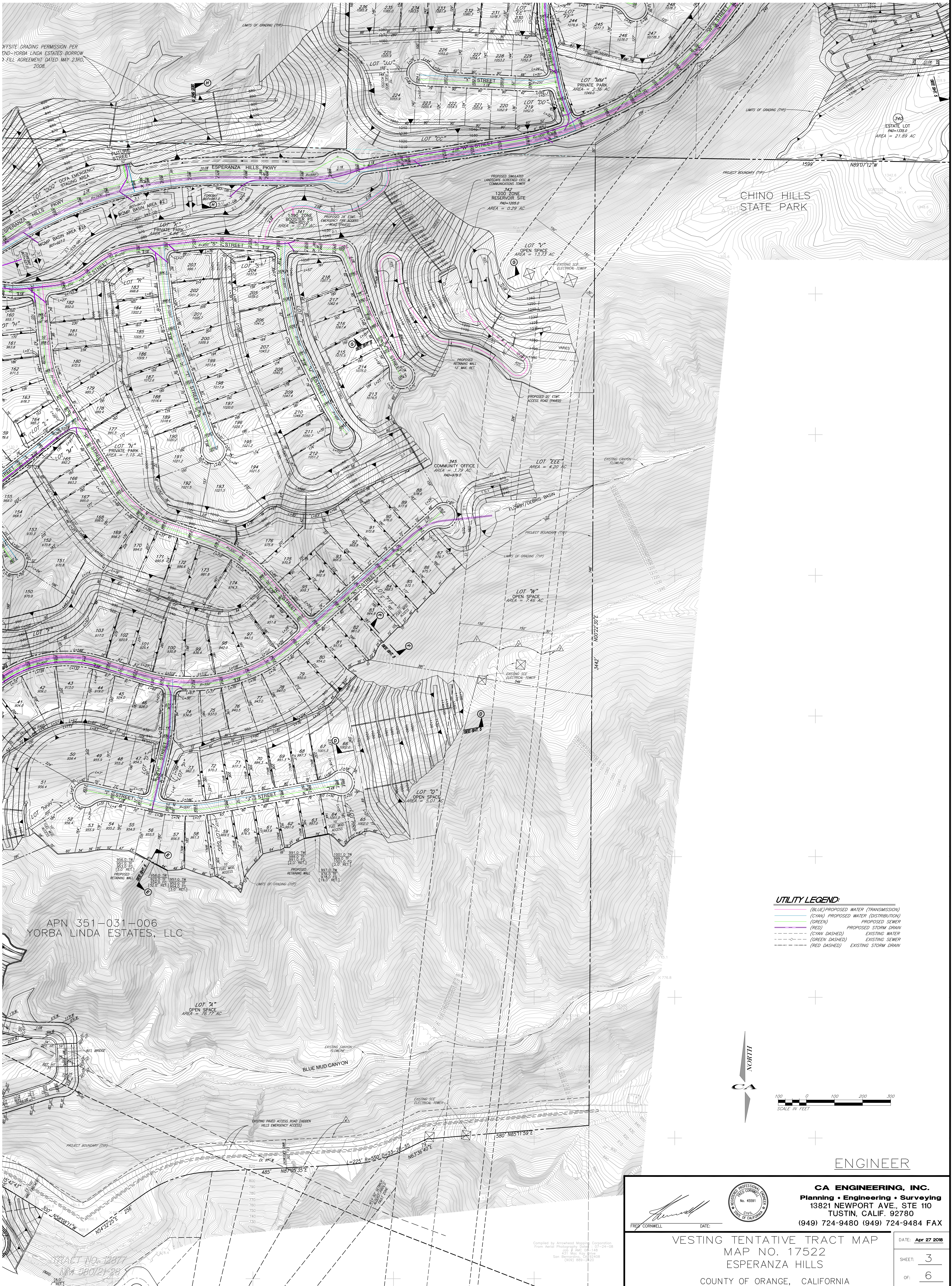

CHINO HILLS STATE PARK

APN 351-031-006  
YORBA LINDA ESTATES, LLC

**UTILITY LEGEND:**

(BLUE) PROPOSED WATER (TRANSMISSION)
(CYAN) PROPOSED WATER (DISTRIBUTION)
(GREEN) PROPOSED SEWER
(RED) PROPOSED STORM DRAIN
(CYAN DASHED) EXISTING WATER
(GREEN DASHED) EXISTING SEWER
(RED DASHED) EXISTING STORM DRAIN

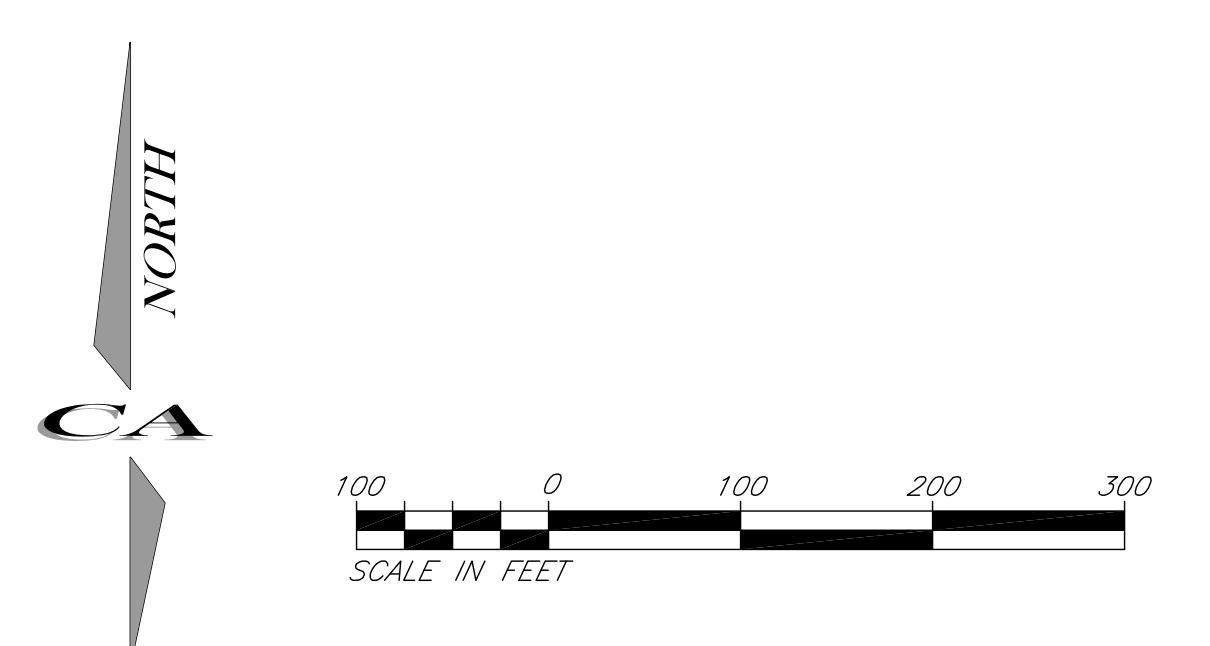

ENGINEER

**CA ENGINEERING, INC.**  
 Planning • Engineering • Surveying  
 13821 NEWPORT AVE., STE 110  
 TUSTIN, CALIF. 92780  
 (949) 724-9480 (949) 724-9484 FAX

VESTING TENTATIVE TRACT MAP  
 MAP NO. 17522  
 ESPERANZA HILLS  
 COUNTY OF ORANGE, CALIFORNIA

DATE: Apr 27 2018  
 SHEET: 3  
 OF: 6

Compiled by Jenaevel Mapping Corporation  
 From Aerial Photography, dated 10/24/08  
 231 Mac Coy Blvd  
 San Bernardino, CA 92404  
 (909) 859-1450





**SEE SHT. 3**

**UTILITY LEGEND:**

- (BLUE) PROPOSED WATER (TRANSMISSION)
- (CYAN) PROPOSED WATER (DISTRIBUTION)
- (GREEN) PROPOSED SEWER
- (RED) PROPOSED STORM DRAIN
- (CYAN DASHED) EXISTING WATER
- (GREEN DASHED) EXISTING SEWER
- (RED DASHED) EXISTING STORM DRAIN

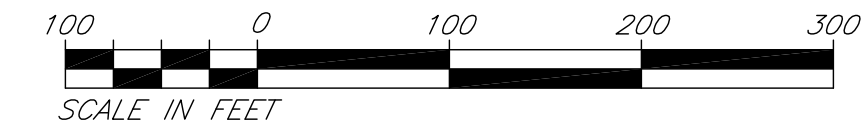
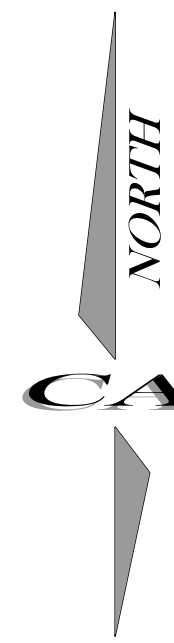

ENGINEER



**CA ENGINEERING, INC.**  
 Planning • Engineering • Surveying  
 13821 NEWPORT AVE., STE 110  
 TUSTIN, CALIF. 92780  
 (949) 724-9480 (949) 724-9484 FAX

VESTING TENTATIVE TRACT MAP  
 MAP NO. 17522  
 ESPERANZA HILLS  
 COUNTY OF ORANGE, CALIFORNIA

DATE: Apr 27 2018  
 SHEET: 4  
 OF: 6

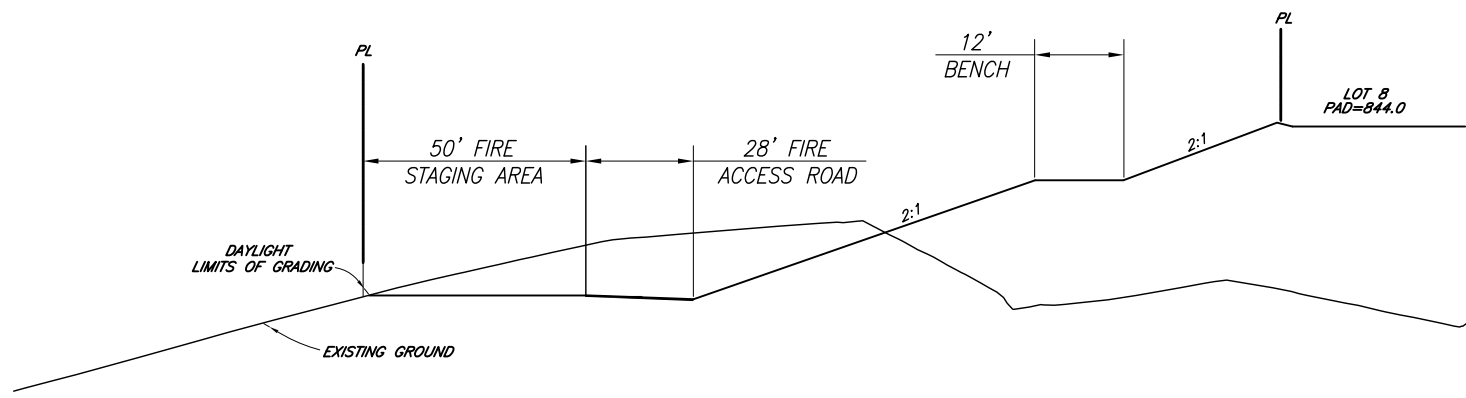

# VESTING TENTATIVE TRACT MAP NO. 17522



**SECTION "O-O"**  
N.T.S.  
SEE SHEET 2 FOR PLAN VIEW

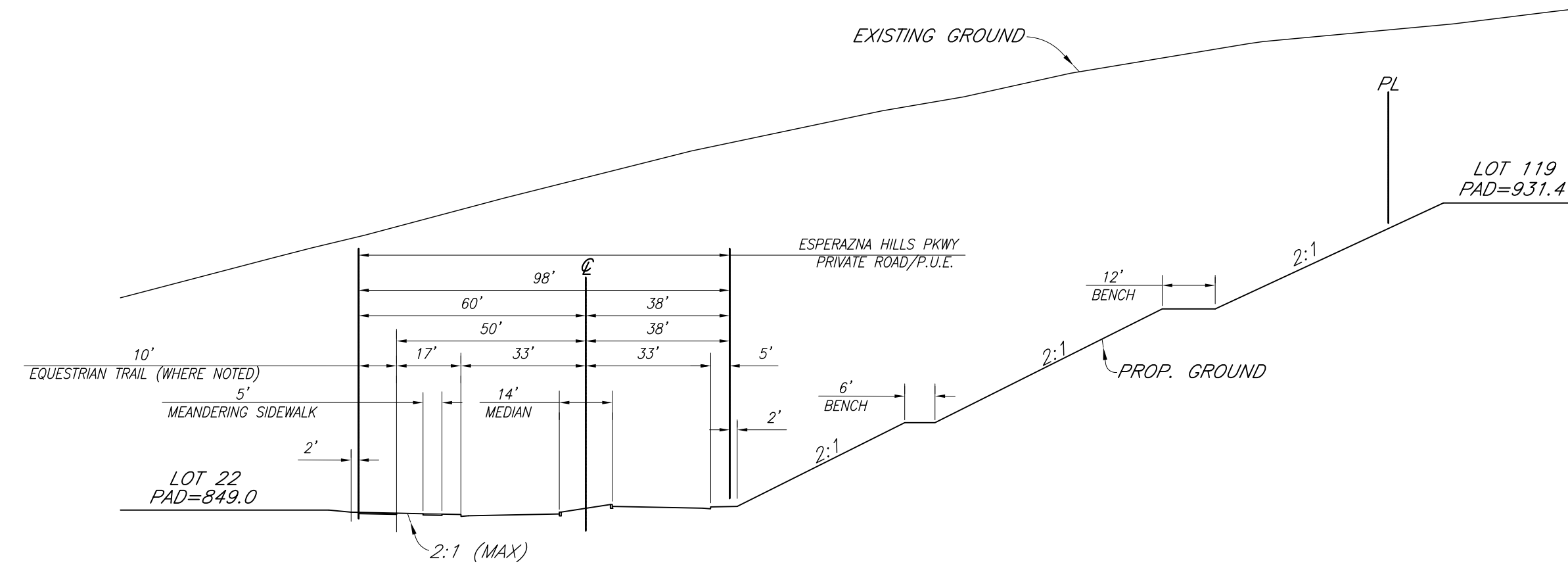

**SECTION "I-I"**  
N.T.S.  
SEE SHEETS 2&3 FOR PLAN VIEW

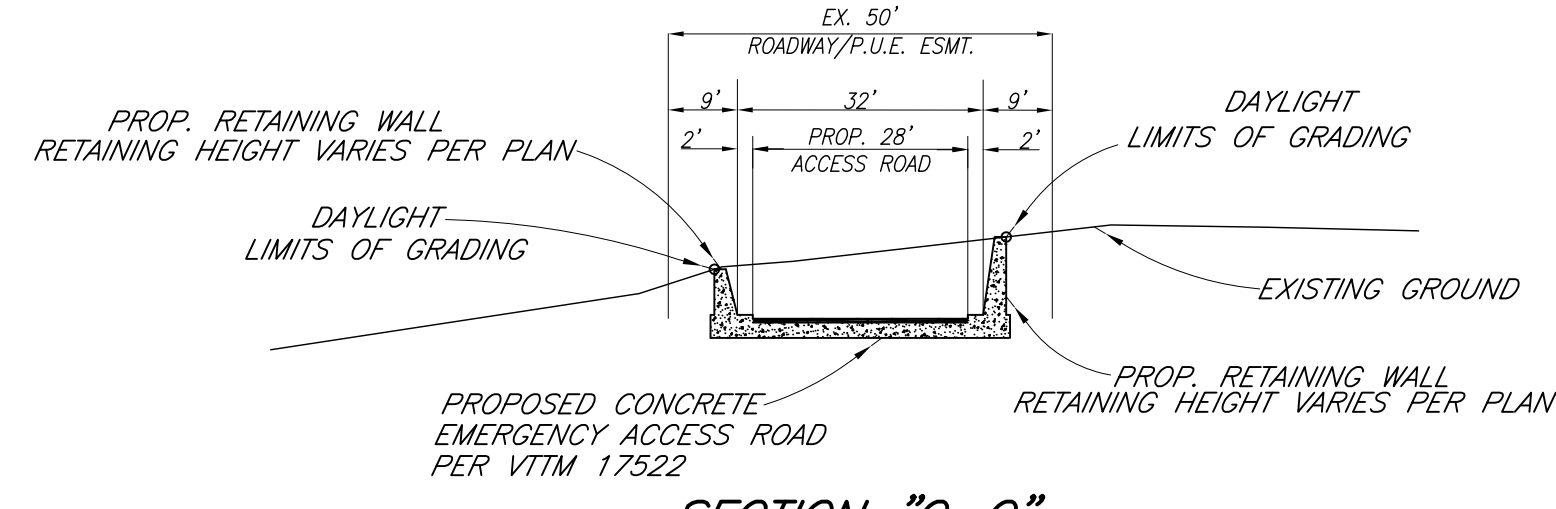

**SECTION "C-C"**  
N.T.S.  
SEE SHEET 2 FOR PLAN VIEW

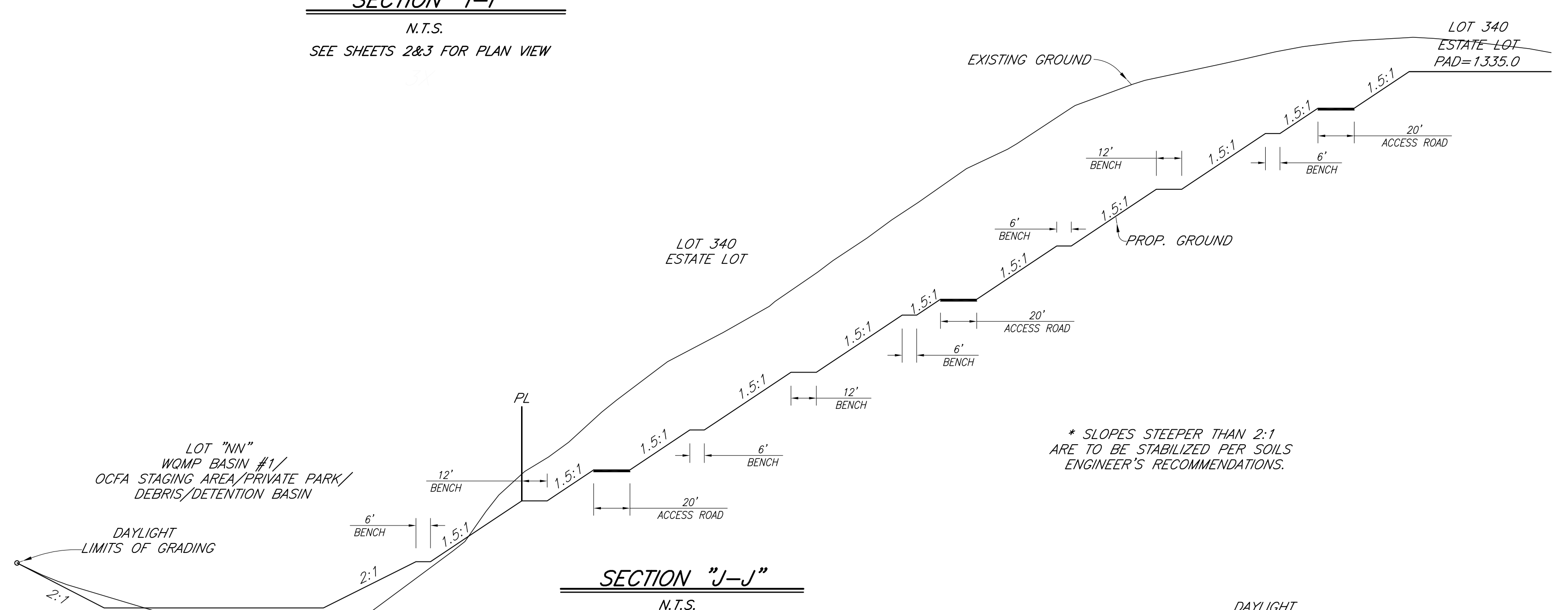

**SECTION "J-J"**  
N.T.S.  
SEE SHEET 4 FOR PLAN VIEW

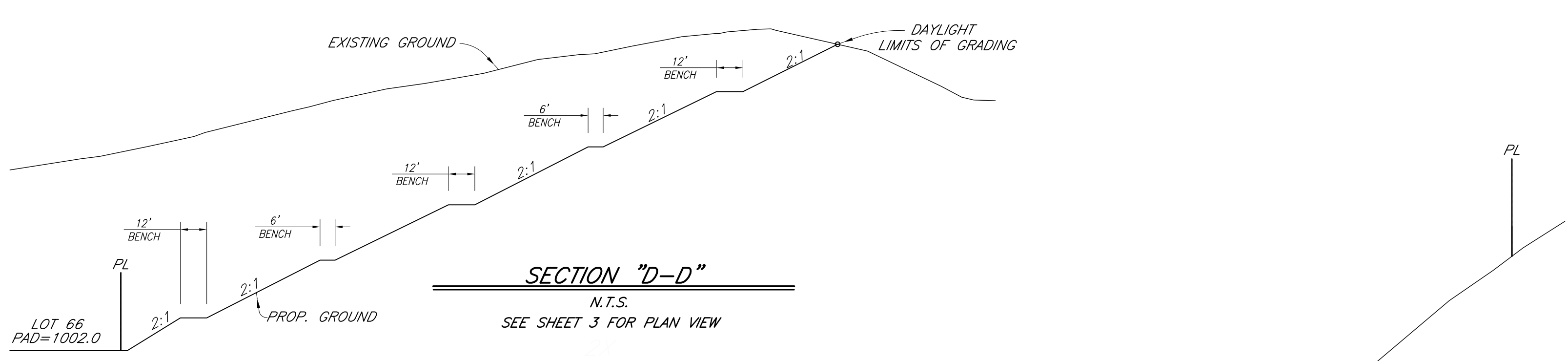

**SECTION "D-D"**  
N.T.S.  
SEE SHEET 3 FOR PLAN VIEW

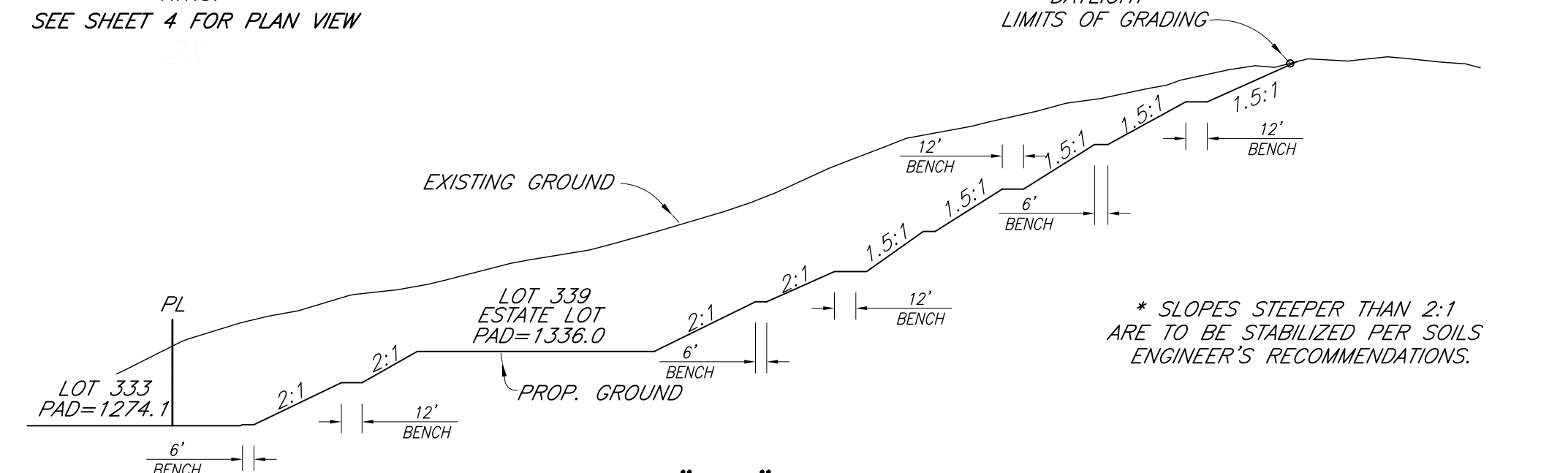

**SECTION "L-L"**  
N.T.S.  
SEE SHEET 4 FOR PLAN VIEW

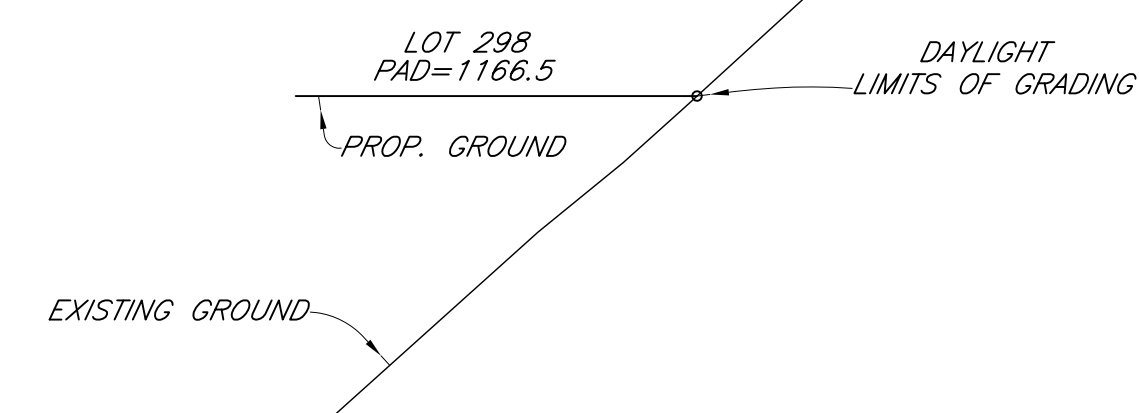

**SECTION "K-K"**  
N.T.S.  
SEE SHEET 4 FOR PLAN VIEW

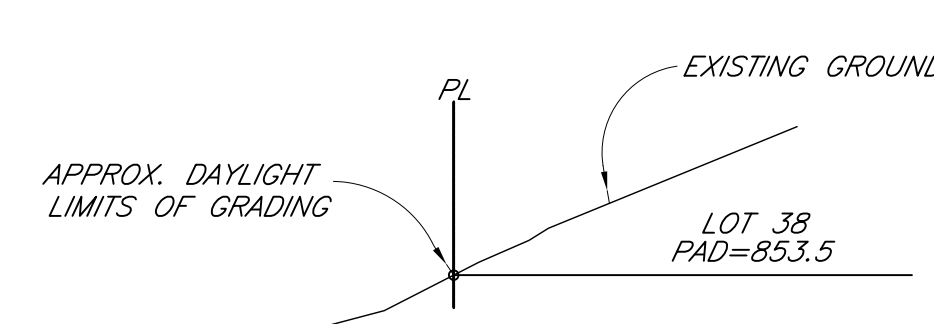

**SECTION "B-B"**  
N.T.S.  
SEE SHEET 2 FOR PLAN VIEW

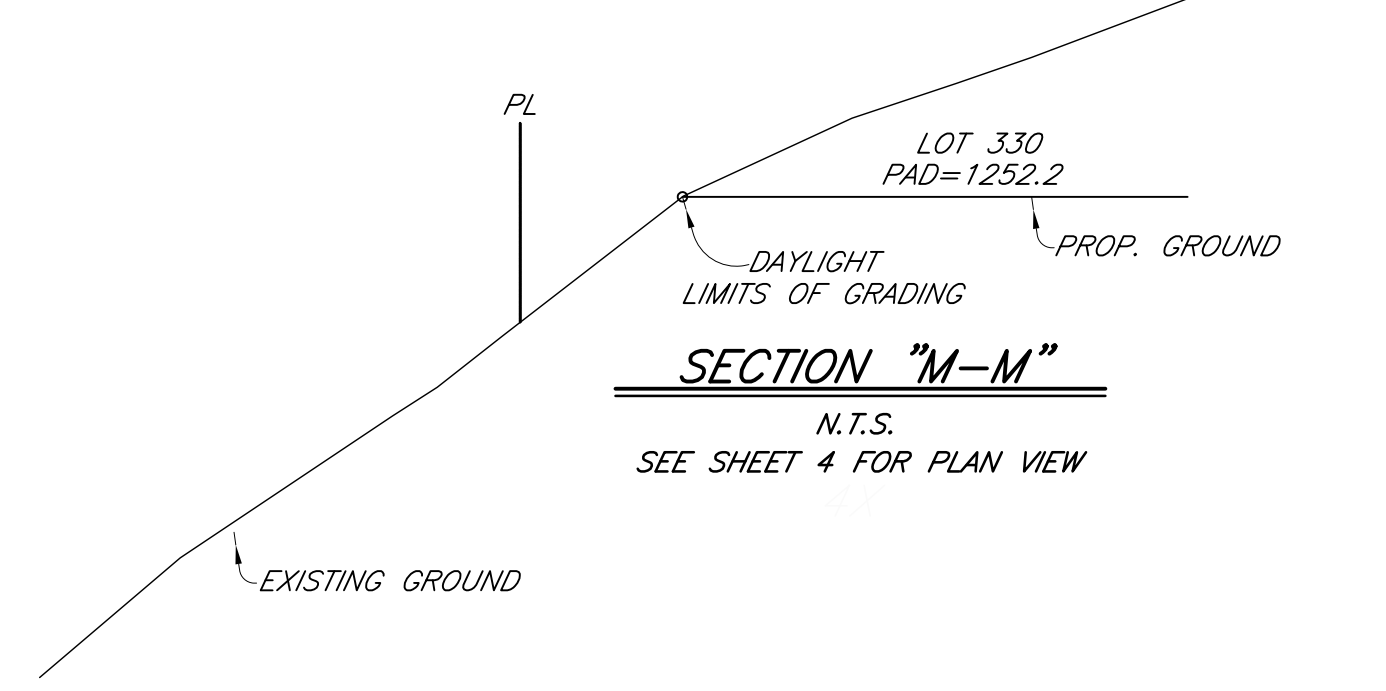

**SECTION "M-M"**  
N.T.S.  
SEE SHEET 4 FOR PLAN VIEW

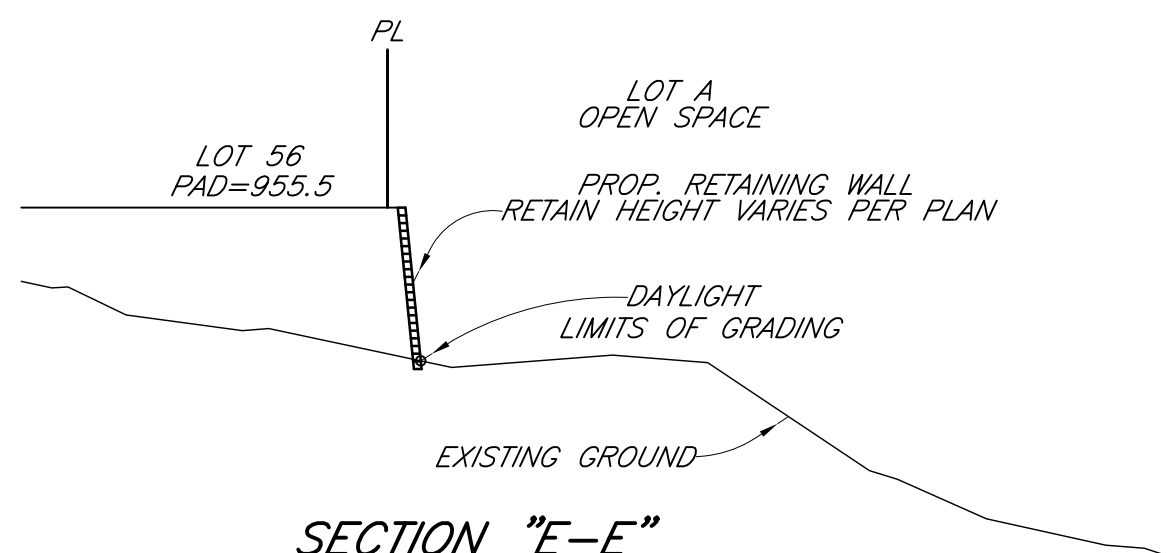

**SECTION "E-E"**  
N.T.S.  
SEE SHEET 2 FOR PLAN VIEW

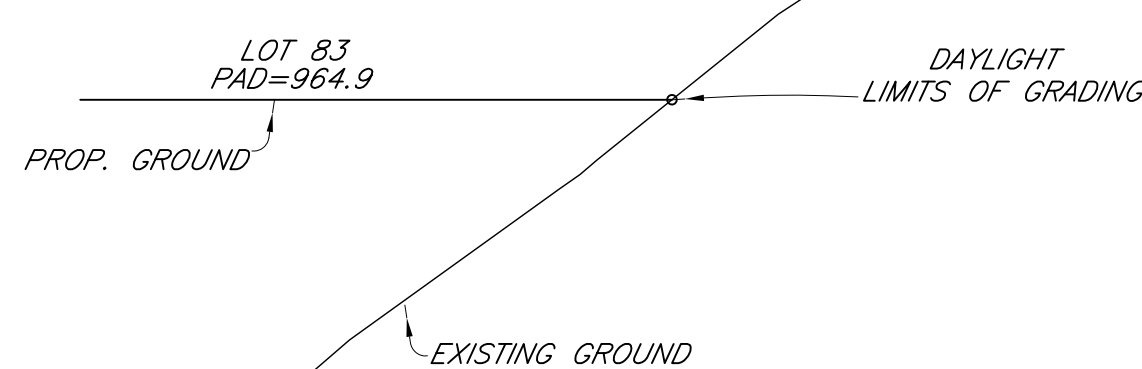

**SECTION "F-F"**  
N.T.S.  
SEE SHEET 3 FOR PLAN VIEW

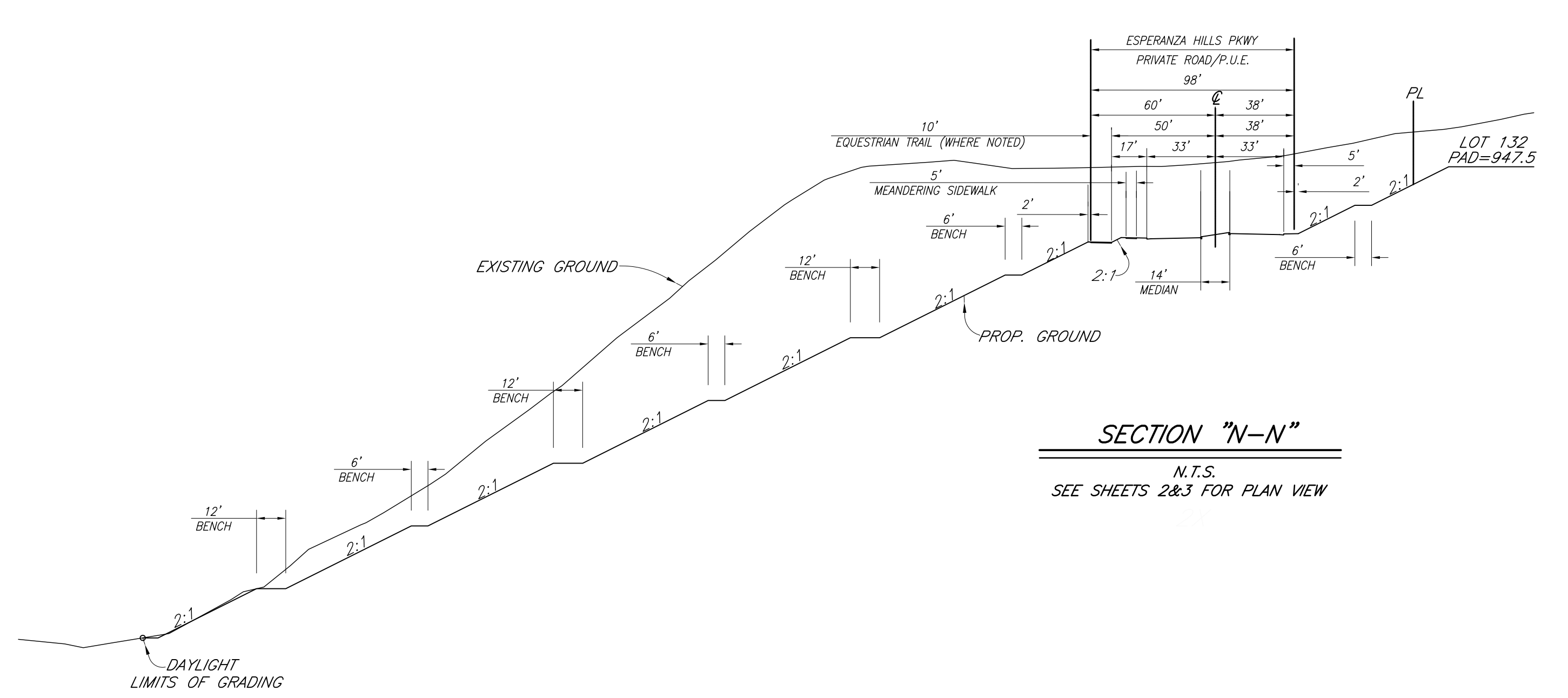

**SECTION "N-N"**  
N.T.S.  
SEE SHEETS 2&3 FOR PLAN VIEW

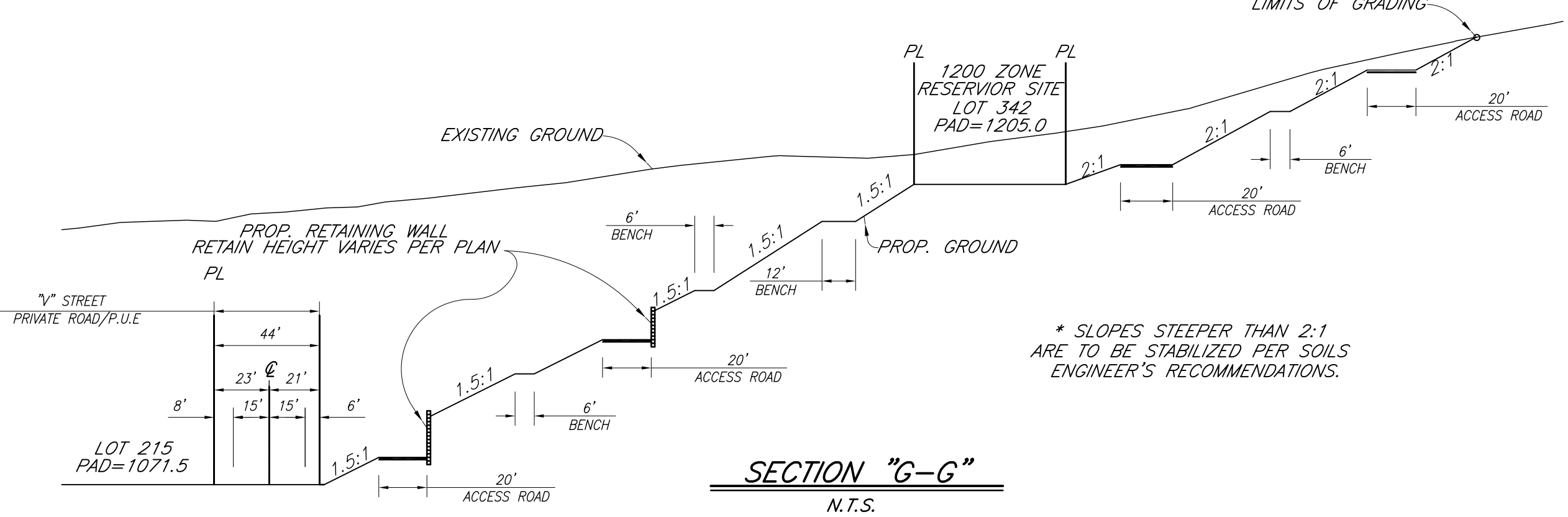

**SECTION "G-G"**  
N.T.S.  
SEE SHEET 3 FOR PLAN VIEW

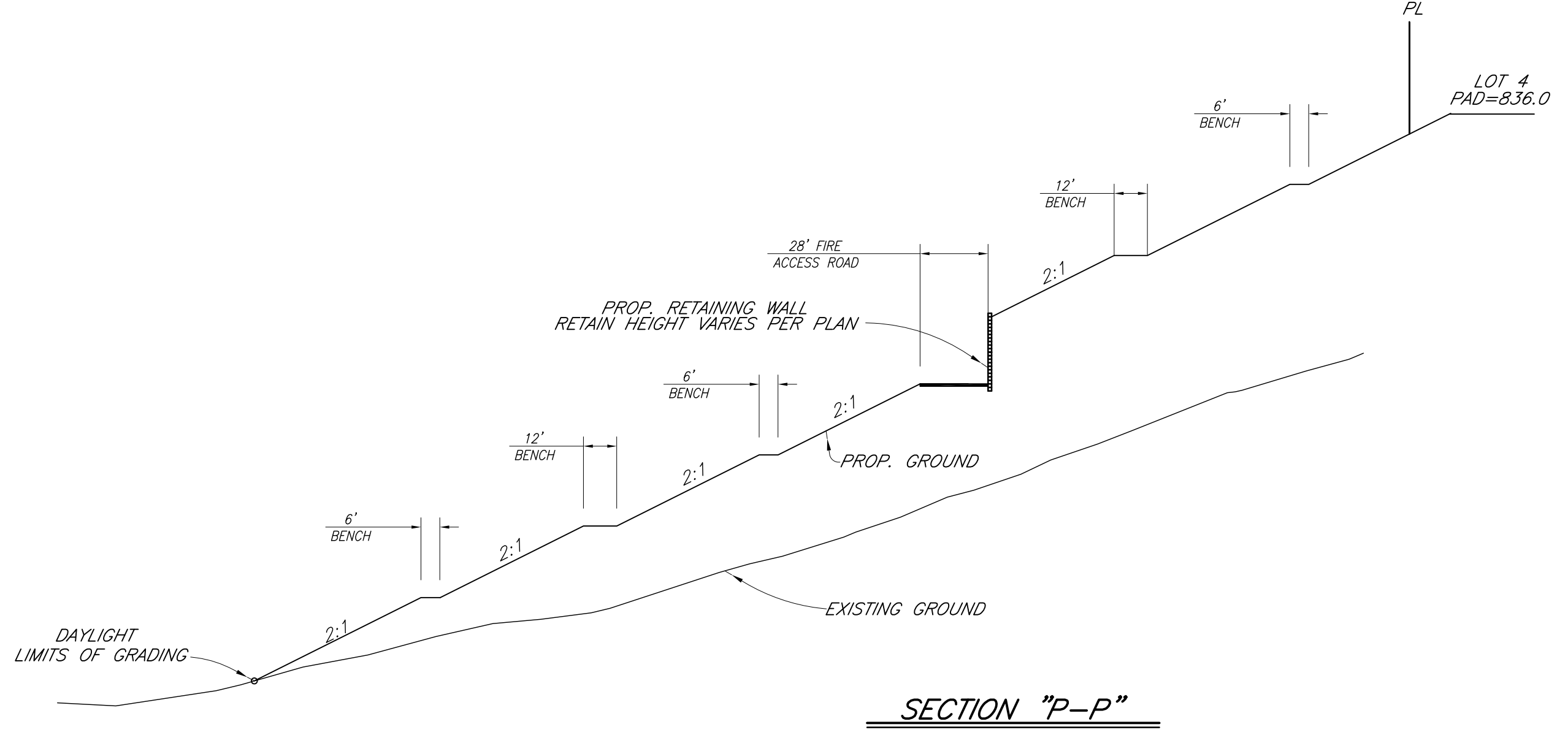

**SECTION "P-P"**  
N.T.S.  
SEE SHEET 2 FOR PLAN VIEW

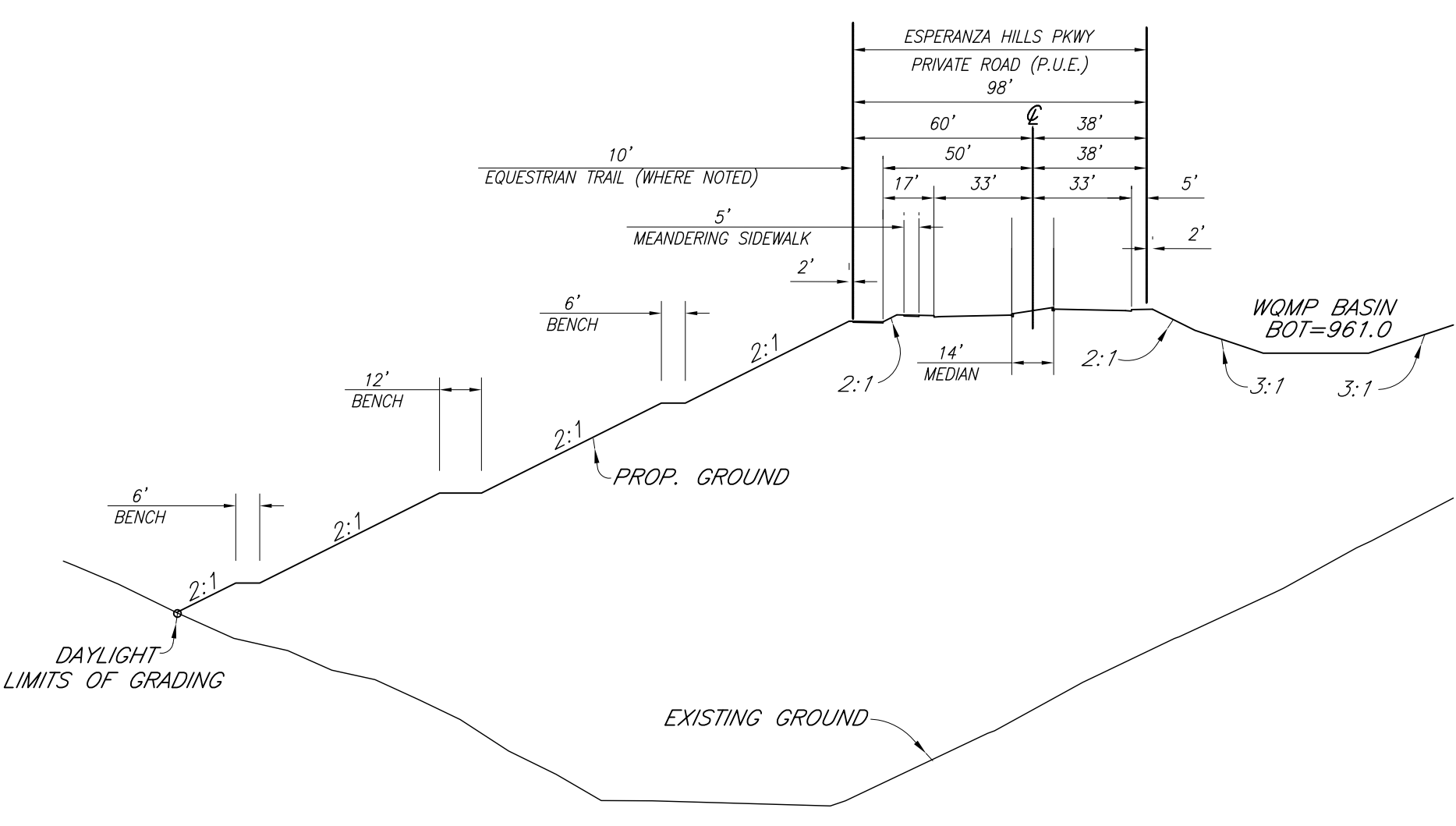

**SECTION "H-H"**  
N.T.S.  
SEE SHEET 3 FOR PLAN VIEW

ENGINEER

**CA ENGINEERING, INC.**  
 Planning • Engineering • Surveying  
 13821 NEWPORT AVE., STE 110  
 TUSTIN, CALIF. 92780  
 (949) 724-9480 (949) 724-9484 FAX

VESTING TENTATIVE TRACT MAP  
 MAP NO. 17522  
 ESPERANZA HILLS  
 COUNTY OF ORANGE, CALIFORNIA

DATE: Apr 27 2018  
 SHEET: 5  
 OF: 6



# VESTING TENTATIVE TRACT MAP NO. 17522 PHASING PLAN



**TRACT MAINTENANCE PLAN**

PROPOSED USE	RESPONSIBLE PARTY FOR CONSTRUCTION	RESPONSIBLE PARTY FOR OWNERSHIP	RESPONSIBLE PARTY FOR MAINTENANCE
ASPEN WAY	YORBA LINDA ESTATES, LLC	YORBA LINDA ESTATES, LLC	PROJECT H.O.A.
ESPERANZA HILLS PKWY	YORBA LINDA ESTATES, LLC	YORBA LINDA ESTATES, LLC	PROJECT H.O.A.
"A", "B", "D" - "Z" STREET	YORBA LINDA ESTATES, LLC	YORBA LINDA ESTATES, LLC	PROJECT H.O.A.
"AA" - "AU" STREET	YORBA LINDA ESTATES, LLC	YORBA LINDA ESTATES, LLC	PROJECT H.O.A.
LOT "A" - "D", "E" - "J", "K", "L", "M", "N" - "X"	YORBA LINDA ESTATES, LLC	YORBA LINDA ESTATES, LLC	PROJECT H.O.A.
LOT "AA" - "LL", "OO" - "UU", "VV" - "ZZ"	YORBA LINDA ESTATES, LLC	YORBA LINDA ESTATES, LLC	PROJECT H.O.A.
LOT "AAA", "DDD", "OOO", "RRR" - "VVV"	YORBA LINDA ESTATES, LLC	YORBA LINDA ESTATES, LLC	PROJECT H.O.A.
LOT "000"	OCFA EMERGENCY STAGING AREA	YORBA LINDA ESTATES, LLC	PROJECT H.O.A.
LOT "E"	ENTRY MONUMENT/PARK	YORBA LINDA ESTATES, LLC	PROJECT H.O.A.
LOT "K"	WOMP/PARK/SLOPE	YORBA LINDA ESTATES, LLC	PROJECT H.O.A.
LOT "N", "Z"	PRIVATE PARK	YORBA LINDA ESTATES, LLC	PROJECT H.O.A.
LOT "Y"	WOMP/SLOPE	YORBA LINDA ESTATES, LLC	PROJECT H.O.A.
LOT "MM", "TT", "VV"	PRIVATE PARK	YORBA LINDA ESTATES, LLC	PROJECT H.O.A.
LOT "NNN"	PRIVATE PARK	YORBA LINDA ESTATES, LLC	PROJECT H.O.A.
LOT "FFF" - "MMM"	FUEL MODIFICATION ACCESS	YORBA LINDA ESTATES, LLC	PROJECT H.O.A.
LOT "CCC", "EEE"	DRAINAGE/SLOPE/OS	YORBA LINDA ESTATES, LLC	PROJECT H.O.A.
LOT "NN", "BBB"	PRIVATE PARK	YORBA LINDA ESTATES, LLC	PROJECT H.O.A.
LOT 339, 340	ESTATE LOT	YORBA LINDA ESTATES, LLC	YORBA LINDA ESTATES, LLC
LOT 341, 344	BOOSTER STATION	YORBA LINDA ESTATES, LLC	YLWD
LOT 342-343	TANK SITE	YORBA LINDA ESTATES, LLC	YLWD
LOT 345	COMMUNITY OFFICE	YORBA LINDA ESTATES, LLC	YORBA LINDA ESTATES, LLC

**TRACT PHASING PLAN**

**NOTES**

1. ALL PHASES SHOWN HEREON ARE PROPOSED RECORDING PHASES AND ARE SUBJECT TO CHANGE.
2. ALL NATURAL AND MANUFACTURED SLOPES NOT INCLUDED WITHIN RESIDENTIAL LOTS SHALL BE MAINTAINED BY THE PROJECT H.O.A.
3. ALL PUBLIC AND PRIVATE WALLS, FENCES AND ENTRY MONUMENTATION AND SIGNAGE SHALL BE MAINTAINED BY THE PROJECT H.O.A.
4. ALL MAINLINE STORM DRAIN SYSTEMS WITHIN PRIVATE ROADWAY SHALL BE MAINTAINED BY COUNTY OF ORANGE.
5. ALL FIRST FLUSH PIPING, WOMP BASINS, AND DRAINAGE/DETENTION FACILITIES WITHIN PROJECT SITE SHALL BE MAINTAINED BY PROJECT H.O.A.
6. ALL UTILITY MAINLINES WITHIN THE PROPOSED PROJECT SITE ARE PUBLIC LINES AND SHALL BE MAINTAINED BY THE PURVEYOR (I.E. SEWER, WATER, POWER, TELEPHONE, C.A.T.V.)

**MAP ACT NOTE**

PER SECTION \_\_\_\_\_ OF THE SUBDIVISION MAP ACT, THIS PROJECT WILL FILING MULTIPLE FINAL MAPS.

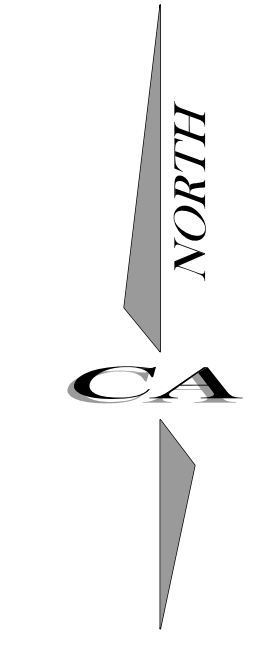

SCALE IN FEET

ENGINEER

  
FRED CORNWELL

  
DATE: \_\_\_\_\_

**CA ENGINEERING, INC.**  
**Planning • Engineering • Surveying**  
 13821 NEWPORT AVE., STE 110  
 TUSTIN, CALIF. 92780  
 (949) 724-9480 (949) 724-9484 FAX

VESTING TENTATIVE TRACT MAP  
 MAP NO. 17522  
 ESPERANZA HILLS  
 COUNTY OF ORANGE, CALIFORNIA

DATE: **Apr 27 2018**  
 SHEET: **6**  
 OF: **6**